

# SERVICE MANUAL



Color Inkjet Printer

**EPSON Stylus Color C70/C80**



**EPSON®**

# Notice

- ❑ All rights reserved. No part of this manual may be reproduced, stored in a retrieval system, or transmitted in any form or by any means electronic, mechanical, photocopying, or otherwise, without the prior written permission of SEIKO EPSON CORPORATION.
- ❑ All effort have been made to ensure the accuracy of the contents of this manual. However, should any errors be detected, SEIKO EPSON would greatly appreciate being informed of them.
- ❑ The contents of this manual are subject to change without notice.
- ❑ All effort have been made to ensure the accuracy of the contents of this manual. However, should any errors be detected, SEIKO EPSON would greatly appreciate being informed of them.
- ❑ The above notwithstanding SEIKO EPSON CORPORATION can assume no responsibility for any errors in this manual or the consequences thereof.

EPSON is a registered trademark of SEIKO EPSON CORPORATION.

*General Notice: Other product names used herein are for identification purpose only and may be trademarks or registered trademarks of their respective owners. EPSON disclaims any and all rights in those marks.*

Copyright © 2000 SEIKO EPSON CORPORATION.  
Imaging & Information Product Division  
TPCS Quality Assurance Center  
TPCS Department

# PRECAUTIONS

Precautionary notations throughout the text are categorized relative to 1) Personal injury and 2) damage to equipment.

***DANGER*** Signals a precaution which, if ignored, could result in serious or fatal personal injury. Great caution should be exercised in performing procedures preceded by DANGER Headings.

***WARNING*** Signals a precaution which, if ignored, could result in damage to equipment.

The precautionary measures itemized below should always be observed when performing repair/maintenance procedures.

## **DANGER**

1. ALWAYS DISCONNECT THE PRODUCT FROM THE POWER SOURCE AND PERIPHERAL DEVICES PERFORMING ANY MAINTENANCE OR REPAIR PROCEDURES.
2. NO WORK SHOULD BE PERFORMED ON THE UNIT BY PERSONS UNFAMILIAR WITH BASIC SAFETY MEASURES AS DICTATED FOR ALL ELECTRONICS TECHNICIANS IN THEIR LINE OF WORK.
3. WHEN PERFORMING TESTING AS DICTATED WITHIN THIS MANUAL, DO NOT CONNECT THE UNIT TO A POWER SOURCE UNTIL INSTRUCTED TO DO SO. WHEN THE POWER SUPPLY CABLE MUST BE CONNECTED, USE EXTREME CAUTION IN WORKING ON POWER SUPPLY AND OTHER ELECTRONIC COMPONENTS.
4. WHEN DISASSEMBLING OR ASSEMBLING A PRODUCT, MAKE SURE TO WEAR GLOVES TO AVOID INJURIES FROM METAL PARTS WITH SHARP EDGES.

## **WARNING**

1. REPAIRS ON EPSON PRODUCT SHOULD BE PERFORMED ONLY BY AN EPSON CERTIFIED REPAIR TECHNICIAN.
2. MAKE CERTAIN THAT THE SOURCE VOLTAGE IS THE SAME AS THE RATED VOLTAGE, LISTED ON THE SERIAL NUMBER/RATING PLATE. IF THE EPSON PRODUCT HAS A PRIMARY AC RATING DIFFERENT FROM AVAILABLE POWER SOURCE, DO NOT CONNECT IT TO THE POWER SOURCE.
3. ALWAYS VERIFY THAT THE EPSON PRODUCT HAS BEEN DISCONNECTED FROM THE POWER SOURCE BEFORE REMOVING OR REPLACING PRINTED CIRCUIT BOARDS AND/OR INDIVIDUAL CHIPS.
4. IN ORDER TO PROTECT SENSITIVE MICROPROCESSORS AND CIRCUITRY, USE STATIC DISCHARGE EQUIPMENT, SUCH AS ANTI-STATIC WRIST STRAPS, WHEN ACCESSING INTERNAL COMPONENTS.
5. DO NOT REPLACE IMPERFECTLY FUNCTIONING COMPONENTS WITH COMPONENTS WHICH ARE NOT MANUFACTURED BY EPSON. IF SECOND SOURCE IC OR OTHER COMPONENTS WHICH HAVE NOT BEEN APPROVED ARE USED, THEY COULD CAUSE DAMAGE TO THE EPSON PRODUCT, OR COULD VOID THE WARRANTY OFFERED BY EPSON.

# About This Manual

This manual describes basic functions, theory of electrical and mechanical operations, maintenance and repair procedures of the printer. The instructions and procedures included herein are intended for the experienced repair technicians, and attention should be given to the precautions on the preceding page.

## Manual Configuration

This manual consists of six chapters and Appendix.

### **CHAPTER 1. PRODUCT DESCRIPTIONS**

Provides a general overview and specifications of the product.

### **CHAPTER 2. OPERATING PRINCIPLES**

Describes the theory of electrical and mechanical operations of the product.

### **CHAPTER 3. TROUBLESHOOTING**

Describes the step-by-step procedures for the troubleshooting.

### **CHAPTER 4. DISASSEMBLY / ASSEMBLY**

Describes the step-by-step procedures for disassembling and assembling the product.

### **CHAPTER 5. ADJUSTMENT**

Provides Epson-approved methods for adjustment.

### **CHAPTER 6. MAINTENANCE**

Provides preventive maintenance procedures and the lists of Epson-approved lubricants and adhesives required for servicing the product.

**APPENDIX** Provides the following additional information for reference:

- Connector pin assignments
- Electric circuit boards components layout
- Electrical circuit boards schematics
- Exploded diagram & Parts List

## Symbols Used in this Manual

Various symbols are used throughout this manual either to provide additional information on a specific topic or to warn of possible danger present during a procedure or an action. Be aware of all symbols when they are used, and always read NOTE, CAUTION, or WARNING messages.



Indicates an operating or maintenance procedure, practice or condition that is necessary to keep the product's quality.



Indicates an operating or maintenance procedure, practice, or condition that, if not strictly observed, could result in damage to, or destruction of, equipment.



May indicate an operating or maintenance procedure, practice or condition that is necessary to accomplish a task efficiently. It may also provide additional information that is related to a specific subject, or comment on the results achieved through a previous action.



Indicates an operating or maintenance procedure, practice or condition that, if not strictly observed, could result in injury or loss of life.



Indicates that a particular task must be carried out according to a certain standard after disassembly and before re-assembly, otherwise the quality of the components in question may be adversely affected.



# Revision Status

Revision	Issued Date	Description
A	July 31, 2001	First Release

# CONTENTS

## Chapter 1 PRODUCT DESCRIPTION

---

<b>1.1 FEATURES</b> .....	<b>10</b>
<b>1.2 SPECIFICATIONS</b> .....	<b>11</b>
1.2.1 Physical Specification .....	11
1.2.2 Printing Specification .....	11
1.2.3 Paper Feeding .....	13
1.2.4 Input Data Buffer .....	13
1.2.5 Electric Specification .....	13
1.2.6 Environmental Condition .....	14
1.2.7 Reliability .....	14
1.2.8 Safety Approvals .....	14
1.2.9 Acoustic Noise .....	14
1.2.10 CE Marking .....	14
<b>1.3 INTERFACE</b> .....	<b>15</b>
1.3.1 Parallel Interface .....	15
1.3.2 Parallel Interface (Reserve Channel) .....	17
1.3.3 USB Interface .....	18
1.3.4 Prevention Hosts of Data Transfer Time-out .....	19
1.3.5 Interface Selection .....	19
1.3.6 IEEE1284.4 Protocol .....	19
1.3.7 Printer Language and Emulation .....	20
1.3.7.1 Control codes .....	20
1.3.7.2 EPSON D4 control channel commands .....	21
<b>1.4 OPERATOR CONTROLS</b> .....	<b>24</b>
1.4.1 Operate Switch .....	24
1.4.2 Control Panel .....	24
1.4.2.1 Switches .....	24
1.4.2.2 Indicators .....	24
1.4.3 Panel Functions .....	25
1.4.4 Printer Condition and Panel Status .....	26
1.4.5 Printer setting mode (Stylus COLOR C80 only) .....	27

1.4.5.1 Default setting mode .....	27
1.4.5.2 Print head alignment mode .....	28
1.4.6 Printer Initialization .....	28
1.4.7 Errors .....	29
<b>1.5 PAPER</b> .....	<b>30</b>
1.5.1 Paper Handling .....	30
1.5.2 Paper Specification .....	30
1.5.2.1 Cut Sheet .....	30
1.5.2.2 Envelope .....	30
1.5.2.3 Index Card .....	30
1.5.2.4 EPSON special media .....	31
1.5.3 Printing Area .....	32
1.5.3.1 Cut Sheet .....	32
1.5.3.2 Envelopes .....	33
<b>1.6 INK CARTRIDGE</b> .....	<b>34</b>
1.6.1 Black Ink Cartridge .....	34
1.6.2 Color Ink Cartridge .....	34

## Chapter 2 Operating Principles

---

<b>2.1 Overview</b> .....	<b>36</b>
2.1.1 Printer Mechanism .....	36
2.1.2 Printhead .....	37
2.1.2.1 Printing Process .....	37
2.1.2.2 Printing Method .....	38
2.1.3 Carriage Mechanism .....	39
2.1.4 Paper Feeding Mechanism .....	40
2.1.5 Paper Loading Mechanism (ASF Unit) .....	41
2.1.6 Ink System Mechanism .....	49
2.1.6.1 Pump Unit & Wiper mechanism .....	49
2.1.6.2 Capping Mechanism .....	50
<b>2.2 Electrical Circuit Operating Principles</b> .....	<b>51</b>

2.2.1 C424 PSB/PSE board .....	51
2.2.2 C424 MAIN-B Board .....	54
2.2.2.1 Main elements .....	55
2.2.2.2 Printhead Driver Circuit .....	56
2.2.2.3 CR / PF Motor (PF/ PUMP/ ASF Motor) Driver Circuit .....	57
2.2.2.4 Reset Circuit .....	57
2.2.2.5 EEPROM Control Circuit .....	58
2.2.2.6 Sensor Circuit .....	58

## Chapter 3 Troubleshooting

---

<b>3.1 Overview .....</b>	<b>61</b>
3.1.1 Communication Error .....	62
3.1.2 Too Late Throughput .....	62
3.1.3 Status Monitor does not operate .....	63
3.1.4 Troubleshooting with LED Error Indications .....	64
3.1.4.1 Remedy when a paper out, double feed or paper jam error occurs .....	66
3.1.4.2 Remedies for No I/C and Ink Out Errors .....	71
3.1.4.3 Countermeasures when an Ink Low indication appears. ....	75
3.1.4.4 Remedies for the Maintenance Error .....	75
3.1.4.5 Remedies for Fatal Error .....	76
3.1.5 Isolating the Faulty Part on the Power Supply Board .....	79
3.1.6 Isolating the Faulty Part according to the Phenomenon .....	82
3.1.6.1 PF Motor Driver Abnormal 1 .....	83
3.1.6.2 ASF Driver Abnormal 1 .....	84
3.1.6.3 Unexpected Ink Out Error 1 (During Print Operation) .....	85
3.1.6.4 PF Motor Driver Abnormal 2 .....	86
3.1.6.5 Carriage Operation Abnormal .....	87
3.1.6.6 Dot Missing 1 .....	89
3.1.6.7 Dot Missing 2 .....	90
3.1.6.8 Dot Missing 3 .....	92
3.1.6.9 Repair Handling Failure .....	93
3.1.6.10 ASF Driver Abnormal 2 .....	93
3.1.6.11 CR Motor Operation Abnormal .....	95

## Chapter 4 Disassembly and Assembly

---

<b>4.1 Overview .....</b>	<b>97</b>
4.1.1 Precautions .....	97

4.1.2 Tools .....	98
4.1.3 Work Completion Check .....	99
4.1.4 Screws .....	100
<b>4.2 Disassembly .....</b>	<b>101</b>
4.2.1 Housing Removal .....	102
4.2.1.1 Printer Cover Removal .....	102
4.2.1.2 Stacker Assembly Removal .....	102
4.2.1.3 Upper Case Removal .....	103
4.2.1.4 Rear Cover Removal .....	104
4.2.1.5 Middle Housing Removal .....	104
4.2.1.6 Printer Mechanism Unit Removal .....	105
4.2.1.7 Waste Ink Pad Removal .....	108
4.2.2 ASF Unit Removal .....	108
4.2.3 Main Board Assembly Removal .....	110
4.2.4 Power Supply Board Assembly Removal .....	111
4.2.5 Print Head / Ink System Unit Removal .....	113
4.2.6 Carriage Unit / CR Guide Shaft Removal .....	116
4.2.7 Front Paper Guide Removal .....	121
4.2.8 EJ Roller Unit Removal .....	122
4.2.9 Motor Removal .....	123
4.2.9.1 PF Motor Removal .....	123
4.2.9.2 CR Motor Removal .....	124
4.2.10 PE Actuator Removal .....	125
4.2.10.1 Encoder Unit Board Removal .....	125
4.2.11 PF Roller Unit Removal .....	126
4.2.12 ASF Unit Disassembly .....	127
4.2.12.1 ASF Assembly Points .....	132
4.2.13 Rotary Encoder Removal .....	134

## Chapter 5 Adjustment

---

<b>5.1 Overview .....</b>	<b>138</b>
5.1.1 Conditions for Each Adjustment .....	138
<b>5.2 Adjustment .....</b>	<b>140</b>
5.2.1 Setup the Adjustment Program .....	140
5.2.2 Head ID Input .....	141
5.2.3 Ink Charge .....	143
5.2.4 Head Angle Adjustment. ....	144
5.2.5 Bi-D Adjustment .....	149
5.2.6 PF Adjustment .....	152

5.2.7 USB ID Readout (Checking) .....	155
5.2.7.1 Possible to Readout the Original USB ID (CASE 1) .....	155
5.2.7.2 Impossible to Readout the Original USB ID (CASE 2) .....	157
5.2.8 EEPROM Initialization .....	157
5.2.9 Platen Gap Adjustment (Mechanism Adjustment) .....	159
5.2.10 Head Cleaning Operation .....	162
5.2.11 Protection Counter Clear (and Check) .....	163
5.2.12 Top Margin Adjustment .....	164
5.2.13 First Dot Position Adjustment .....	166

## Chapter 6 Maintenance

---

<b>6.1 Overview .....</b>	<b>170</b>
6.1.1 Cleaning .....	170
6.1.2 Service Maintenance .....	171
6.1.3 Lubrication and Adhesion .....	172
6.1.4 Lubrication the Carriage Guide Shaft .....	173

## Chapter 7 Appendix

---

<b>7.1 Connector Summary .....</b>	<b>183</b>
7.1.1 Major Component Unit .....	183
7.1.2 EEPROM Address Map .....	187
7.1.3 CSIC Address Map .....	193
<b>7.2 Component Layout .....</b>	<b>196</b>
<b>7.3 Exploded Diagram .....</b>	<b>198</b>
<b>7.4 Parts List .....</b>	<b>208</b>
<b>7.5 Electrical Circuits .....</b>	<b>213</b>

**CHAPTER**

**1**

**PRODUCT DESCRIPTION**

## 1.1 FEATURES

The major features of EPSON color inkjet printers EPSON Stylus COLOR C70 / C80 are:

- High Color Print Quality
  - 2880 (H) X 720 (V) dpi printing
  - 4 Color Printing (YMCK)
- Built-in Auto Sheet Feeder
  - Holds 150 cut-sheets (64g/m<sup>2</sup>)
  - Holds 15 envelopes
- Built-in 2 I/F
  - Bi-directional parallel I/F (IEEE-1284 level 1 device)
  - USB
- Windows/Macintosh exclusive (Stylus COLOR C70 only )
- 1 scalable fonts, 2 LQ fonts (Stylus COLOR C80 only )
  - Roman (scalable)
  - Roman, Courier (LQ)
- Accessory
  - Enclosed parts
 

User's manual:	1
Driver disk:	1
Black ink cartridge:	1
Cyan ink cartridge:	1
Magenta ink cartridge:	1
Yellow ink cartridge:	1
Power cord:	1 (220-240 version)



**Figure 1-1. Product's external view**

## 1.2 SPECIFICATIONS

This section covers specifications of the printers.

### 1.2.1 Physical Specification

- Weight: 5.8kg (without the ink cartridges)
- Dimension: 452 mm (W) x 562 mm (D) x 295 mm (H)

### 1.2.2 Printing Specification

- Print Method
  - On demand ink jet
- Nozzle Configuration
  - Monochrome 180 nozzles
  - Color 60 nozzles x 3 (Cyan, Magenta, Yellow)

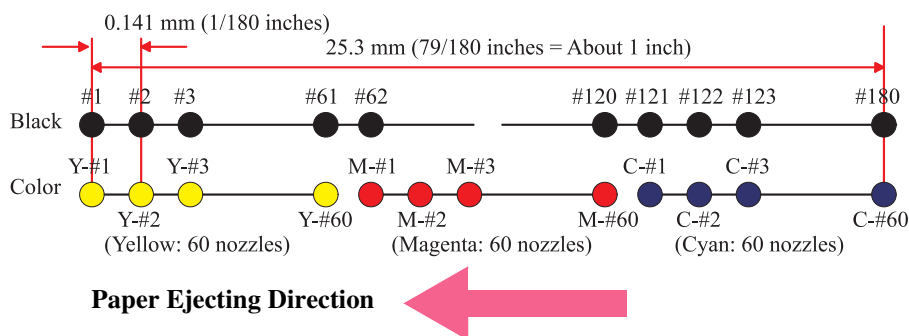

- Print Direction
  - Bi-direction with logic seeking
- Print Speed & Printable Columns\*

**Table 1-1. Character Mode (Stylus COLOR C70)**

Character Pitch	Printable Columns	LQ Speed
10 CPI (Pica)	80	238 CPS

**Table 1-2. Character Mode (Stylus COLOR C80)**

Character Pitch	Printable Column	LQ Speed
10 CPI (Pica)	80	238 CPS
12 CPI (Elite)	96	285 CPS
15 CPI	120	357 CPS
17 CPI (Pica condensed)	137	406 CPS
20 CPI (Elite condensed)	160	476 CPS

**Table 1-3. Raster Graphics Mode**

Horizontal Resolution	Printable Area	Available Dot	CR Speed
180 dpi	209.8mm(8.26 inch)	1488	762/482.6 mm/s 30/19 IPS
360 dpi	209.8mm(8.26 inch)	2976	571.5/482.6 mm/s 22.5/19 IPS
720 dpi	209.8mm(8.26 inch)	5952	482.6 mm/s 19 IPS

- Control Code\*
  - ESC/P2 expanded raster graphics code
  - EPSON Remote command
- Character Tables\*
 

(Stylus COLOR C70)

  - 2 international character sets:
    - PC 437 (US Standard Europe)
    - PC 850 (Multilingual)

**NOTE:** But user cannot select.  
PC437 is the default setting.

(Stylus COLOR C80)

- legal and 14 international character sets (38 character tables)

Typeface\*

(Stylus COLOR C70)

- Bit map LQ font:
  - EPSON Courier 10 CPI

(Stylus COLOR C80)

- Bit map LQ font:
  - EPSON Roman 10 CPI, 12 CPI, 15 CPI, Proportional
  - EPSON Courier 10 CPI, 12 CPI, 15 CPI
- Scalable font
  - EPSON Roman 0.5 pt., 8 pt. - 32pt.(every 2 pt.)

**NOTE:** Each Typeface has 4 variations as the following example of EPSON Roman.

- EPSON Roman normal
- EPSON Roman bold
- EPSON Roman italic
- EPSON Roman bold italic

**NOTE:** (\*)Do not mention to the user's manual.

Character table and Typeface (Stylus COLOR C80 only )

**Table 1-4. Character table and Typeface**

	Character table	Bit map font	Scalable font
		EPSON Roman EPSON Courier	EPSON Roman
DOS version	Italic table PC 437(US Standard Europe) PC 850 (Multilingual) PC 860(Portuguese) PC 861(Icelandic) PC 865(Nordic) BRASCII Abicomp Roman 8 ISO Latin 1 PC 858 ISO 8859-15	supported	supported
	PC 437 Greek PC 852(East Europe) PC 853(Turkish) PC 855(Cyrillic) PC 857(Turkish) PC 866(Russian) PC 869(Greek) MAZOWIA(Poland) Code MJK(CSFR) ISO 8859-7(Latin/Greek) ISO Latin 1T(Turkish) Bulgaria(Bulgaria) PC 774 Estonia ISO 8859-2(ISO Latin 2) PC 866 LAT PC 866 UKR	supported	supported
	PC APTEC(Arabic) PC 708(Arabic) PC 720(Arabic) PC AR864(Arabic)	EPSON Roman	not supported
	Hebrew 7* Hebrew 8* PC 862(Hebrew)*	EPSON Roman	

**NOTE:** (\*) Do not describe in manual. These character tables can't select in the Default setting mode.



### 1.2.3 Paper Feeding

- Feeding Method
  - Friction feed with ASF
- Paper Path
  - Cut-sheet ASF (Top entry Front out)
- Feed Speed
  - 59.994 mm/sec (2.36 inch/sec) (Normal, continuous feed)
  - 114.3 mm/sec (4.5 inch/sec) (Fast, continuous feed)

### 1.2.4 Input Data Buffer

(Stylus COLOR C70)

- 32KB

(Stylus COLOR C80)

- 256KB

### 1.2.5 Electric Specification

#### [120V Version]

Rated Voltage:	AC120V
Input Voltage Range:	AC99~132V
Rated Frequency Range:	50~ 60Hz
Input Frequency Range:	49.5~ 60.5Hz
Rated Current:	0.6A (max. 1.2A)
Power Consumption:	Approx. T.B.D (ISO 10561 Letter Pattern) Approx. 5W in standby mode Energy Star compliant
Insulation Resistance:	10 M ohms min. (between AC line and chassis, DC 500V)
Dielectric Strength:	AC 1000V rms. 1 minute or AC 1200V rms. 1second (between AC line and chassis)

#### [220 ~ 240V Version]

Rated Voltage:	AC220V~240V
Input Voltage Range:	AC198~264V
Rated Frequency Range:	50~60Hz
Input Frequency Range:	49.5~60.5Hz
Rated Current:	0.3A (max. 0.6A)
Power Consumption:	Approx. T.B.D (ISO10561 Letter Pattern) Approx. 5W in standby mode Energy Star compliant
Insulation Resistance:	10 M ohms min. (between AC line and chassis, DC 500V)
Dielectric Strength:	AC 1500V rms. 1 minute (between AC line and chassis)

### 1.2.6 Environmental Condition

- Temperature
  - Operating: 10 to 35°C (\*3)
  - Non-operating: -20 to 40°C (\*1)  
1 month at 40°C and 120 hours at 60°C
- Humidity
  - Operating: 20 to 80% RH (\*2, \*3)
  - Non-operating: 5 to 85% RH (\*1, \*2)
- Resistance to Shock
  - Operating: 1G, within 1 ms
  - Non-operating: 2G, within 2 ms (\*1)
- Resistance to Vibration
  - Operating: 0.15G
  - Non-operating: 0.50G (\*1)

NOTE: (\*1) with shipment container

NOTE: (\*2) without condensation

NOTE: (\*3) Condition is as following figure

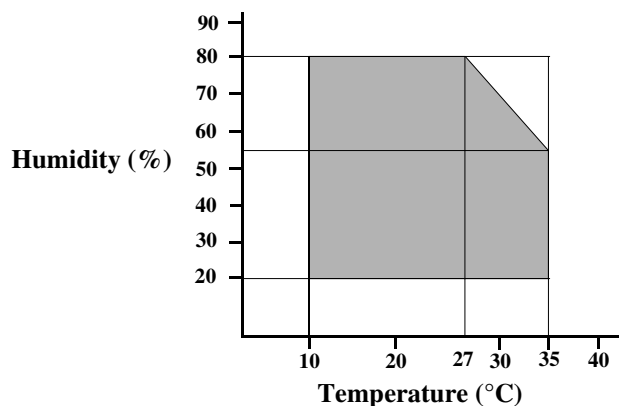

Figure 1-2. Temperature/Humidity Range

### 1.2.7 Reliability

Total Print Volume: 75,000 pages (A4, Letter)

Print Head Life: 3000 million dots/nozzle

### 1.2.8 Safety Approvals

#### [120V Version]

Safety Standards: UL1950  
CSA 22.2 No.950

EMI: FCC part 15 subpart B Class B  
CSA C108.8 Class B

#### [220~240V Version]

Safety Standards: EN60950 (VDE)

EMI: EN55022 (CISPR Pub.22) Class B  
AS/NZS 3548 Class B

### 1.2.9 Acoustic Noise

Level: Approx. 42dB(A) (According to ISO 7779)

### 1.2.10 CE Marking

#### [220~240V Version]

Low Voltage Directive 73/23/EEC: EN60950  
EMC Directive 89/336/EEC: EN55022 Class B  
EN55024  
EN61000-3-2  
EN61000-3-3

### 1.3 INTERFACE

The EPSON Stylus COLOR C70 / C80 provide USB and parallel interface as standard.

#### 1.3.1 Parallel Interface

Transmission Mode: 8 bit parallel, IEEE-1284 compatibility mode  
 Synchronization: By STROBE pulse  
 Handshaking: By BUSY and ACKNLG signal  
 Signal Level: TTL compatible level  
 Adaptable Connector: 57-30360 (amphenol) or equivalent

BUSY signal is set high before setting either -ERROR low or PE high and held high until all these signals return to their inactive state.

BUSY signal is at high level in the following cases.

- During data entry (see Data transmission timing)
- When input data buffer is full
- During -INIT signal is at low level or during hardware initialization
- During printer error (see -ERROR signal)
- When the parallel interface is not selected

ERROR signal is at low level when the printer is in one of the following states.

- Printer hardware error (fatal error)
- Paper-out error
- Paper-jam error
- Ink-out error
- Maintenance request
- Double feed

PE signal is at high level during paper-out error.

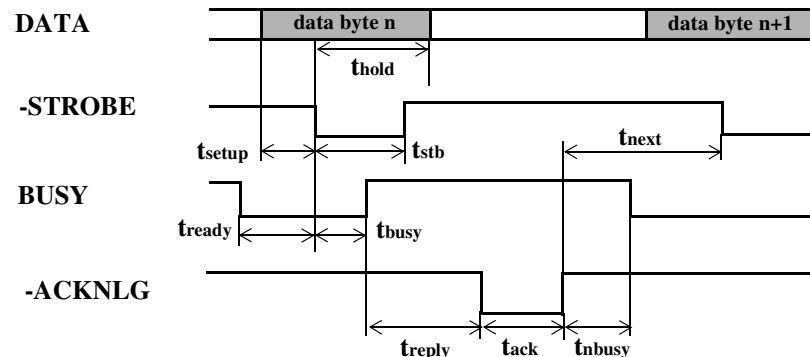

Figure 1-3. Data Transmission Timing

Table 1-5. Parameter

Parameter	Minimum	Maximum
tsetup	500ns	-
thold	500ns	-
tstb	500ns	-
tready	0	-
tbusy	-	500ns
tt-out (*1)	-	120ns
tt-in (*2)	-	200ns
treply	0	-
tack	500ns	10us
tnbusy	0	-
tn timer	0	-

NOTE: (\*1) Rise and fall time of every output signal.

NOTE: (\*2) Rise and fall time of every input signal.

Table 1-6. Typical Time of tack

Parallel I/F Mode	Typical Time of tack
High Speed	0.5us
Normal Speed	2us

Table 1-7. Signal Level: TTL Compatible (IEEE-1284 level 1 device)

Parameter	Minimum	Maximum	Condition
VOH*	-	5.5V	
VOL*	-0.5V	-	
IOH*	-	0.32mA	VOH = 2.4V
IOL*	-	12mA	VOL = 0.4V
CO	-	50pF	
VIH	-	2.0V	
VIL	0.8V	-	
I <sub>IH</sub>	-	0.32mA	VIH = 2.0V
I <sub>IL</sub>	-	12mA	VIL = 0.8V
CI	-	50pF	

**NOTE:** (\*) A low logic level on the Logic H signal is 2.0V or less when the printers powered off and this signal is equal or exceeding 3.0V when the printer is powered on. The receiver shall provide an impedance equivalent to 7.5K ohm to ground.

Table 1-8. Connector Pin Assignment and Signals

Pin No.	Signal Name	Return GND Pin	In/Out	Functional Description
1	-STROBE	19	In	The strobe pulse. Read-in of data is performed at the falling edge of this pulse.
2	DATA 0	20	In	The DATA 0 through DATA 7 signals represent data bits 0 to 7, respectively. Each signal is at high level when data is logical 1 and low level when data is logical 0.
3	DATA 1	21	In	

Table 1-8. Connector Pin Assignment and Signals (continued)

Pin No.	Signal Name	Return GND Pin	In/Out	Functional Description
4	DATA 2	22	In	The DATA 0 through DATA 7 signals represent data bits 0 to 7, respectively. Each signal is at high level when data is logical 1 and low level when data is logical 0.
5	DATA 3	23	In	
6	DATA 4	24	In	
7	DATA 5	25	In	
8	DATA 6	26	In	
9	DATA 7	27	In	
10	-ACKNLG	28	Out	This signal is a negative pulse indicating that the printer can accept data again.
11	BUSY	29	Out	A high signal indicates that the printer cannot receive data.
12	PE	28	Out	A high signal indicates paper-out error.
13	SLCT	28	Out	Always at high level when the printer is powered on.
14	-AFXT	30	In	Not used.
31	-INIT	30	In	The falling edge of a negative pulse or a low signal on this line causes the printer to initialize. Minimum 50 us pulse is necessary.
32	-ERROR	29	Out	A low signal indicates printer error condition.
36	-SLIN	30	In	Not used.
18	Logic H	-	Out	Pulled up to +5V via 3.9 K ohm resistor.
35	+5V	-	Out	Pulled up to +5V via 3.3K ohm resistor.
17	Chassis GND	-	-	Chassis GND
16,33, 19-30	GND	-	-	Signal GND
15,34	NC	-	-	Not connected

**NOTE:** In/Out refers to the direction of signal flow from the printer's point of view.

### 1.3.2 Parallel Interface (Reserve Channel)

Transmission Mode: IEEE-1284 nibble mode  
 Adaptable Connector: See forward channel  
 Synchronization: Refer to the IEEE-1284 specification  
 Handshaking: Refer to the IEEE-1284 specification  
 Data Trans. Timing: Refer to the IEEE-1284 specification  
 Signal Level: IEEE-1284 level 1 device  
 See forward channel

**Table 1-9. Connector Pin Assignment and Signals**

Pin No.	Signal Name	Return GND Pin	In/Out	Functional Description
1	Host Clk	19	In	Host clock signal.
2	DATA 0	20	In	The DATA 0 through DATA 7 signals represent data bits 0 to 7, respectively. Each signal is at high level when data is logical 1 and low level when data is logical 0. These signals are used to transfer the 1284 extensibility request values to the printer.
3	DATA 1	21	In	
4	DATA 2	22	In	
5	DATA 3	23	In	
6	DATA 4	24	In	
7	DATA 5	25	In	
8	DATA 6	26	In	
9	DATA 7	27	In	
10	PtrClk	28	Out	Printer clock signal.
11	PtrBusy / DataBit-3,7	29	Out	Printer busy signal and reverse channel transfer data bit 3 or 7.
12	AckDataReq / DataBit-2,6	28	Out	Acknowledge data request signal and reverse channel transfer data bit 2 or 6.
13	Xflag / DataBit-1,5	28	Out	X-flag signal and reverse channel transfer data bit 1 or 5.
14	Host Busy	30	In	Host busy signal.
31	-INIT	30	In	Not used.

**Table 1-9. Connector Pin Assignment and Signals (continued)**

Pin No.	Signal Name	Return GND Pin	In/Out	Functional Description
32	-DataAvail / DataBit-0,4	29	Out	Data available signal and reverse channel transfer data bit 0 or 4.
36	1284-Active	30	In	1284 active signal.
18	Logic-H	-	Out	Pulled up to +5V via 3.9K ohm resistor.
35	+5V	-	Out	Pulled up to +5V via 3.3K ohm resistor.
17	Chassis GND	-	-	Chassis GND
16,33, 19-30	GND	-	-	Signal GND
15,34	NC	-	-	Not connected

**NOTE:** In/Out refers to the direction of signal flow from the printer's point of view.

**Extensibility Request:**

The printer responds affirmatively when the extensibility request values are 00H or 04H, that mean,

- 00H: Request Nibble Mode Reverse Channel Transfer.
- 04H: Request Device ID;  
Return Data Using Nibble Mode Rev Channel Transfer.

**Device ID:**

The printer sends the following device ID string when it is requested.

When IEEE1284.4 is enabled,  
 [00H] [4EH]  
 MFG: EPSON;  
 CMD: ESCPL2, BDC, D4;  
 MDL: STYLUS[SP]COLOR[SP]C70/C80;  
 CLS: PRINTER;  
 DES: EPSON[SP]STYLUS[SP]COLOR[SP]C70/C80;

When IEEE1284.4 is disabled,  
 [00H] [4BH]  
 MFG: EPSON;  
 CMD: ESCPL2, BDC;  
 MDL: STYLUS[SP]COLOR[SP]C70/C80;  
 CLS: PRINTER;  
 DES: EPSON[SP]STYLUS[SP]COLOR[SP]C70/C80;

**1.3.3 USB Interface**

- Standard: Based on  
 “Universal Serial Bus Specifications Revision 1.0”  
 “Universal Serial Bus Device Class Definition  
 for Printing Devices Version 1.0”
- Bit Rate: 12 M bps (Full Speed Device)
- Data Encoding: NRZI
- Adaptable Connector: USB Series B
- Recommended Cable Length: 2 meters

**Table 1-10. Connector Pin Assignment and Signals**

Pin No.	Signal Name	I/O	Function Description
1	VCC	-	Cable power. Max. power consumption is 2mA
2	-Data	Bi-Directional	Data
3	+Data	Bi-Directional	Data, pull up to +3.3 V via 1.5K ohm resistor
4	Ground	-	Cable ground

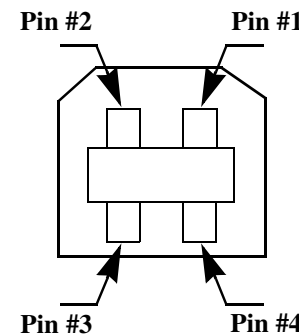

**Figure 1-4. USB Pin Assignment**

### 1.3.4 Prevention Hosts of Data Transfer Time-out

Generally, hosts abandon data transfer to peripherals when a peripheral is in the busy state for dozens of seconds continuously. To prevent hosts from this kind of time-out, the printer receives data very slowly, several bytes per minute, even if the printer is in busy state. The slowdown is started when the rest of the input buffer becomes several hundreds of bytes. Finally the printer is in the busy state continuously when the input buffer is full.

USB and IEEE1284.4 on the parallel interface do not require this function.

### 1.3.5 Interface Selection

The printer has 2 built-in interfaces: the USB and parallel interface.

These interfaces are selected automatically.

#### Automatic Selection

In this automatic interface selection mode, the printer is initialized to the idle state scanning which interface receives data when it is powered on. Then the interface that receives data first is selected. When the host stops data transfer and the printer is in the stand-by state for the seconds, the printer is returned to the idle state. As long as the host sends data or the printer interface is busy state, the selected interface is let as it is.

The changes to other Interface are prohibited during Duplex printing.

#### Interface State and Interface Selection

When the parallel interface is not selected, the interface got into the busy state.

When the printer is initialized or returned to the idle state, the parallel interface got into the ready state. Caution that the interrupt signal such as the -INIT signal on the parallel interface is not effective while that interface is not selected.

### 1.3.6 IEEE1284.4 Protocol

The packet protocol described by IEEE1284.4 standard allows a device to carry on multiple exchanges or conversations which contain data and/or control information with another device at the same time across a single point-to-point link. The protocol is not, however, a device control language. It does provide basic transport-level flow control and multiplexing services. The multiplexed logical channels are independent of each other and blocking of one has no effect on the others. The protocol operate over IEEE1284.

#### Automatic Selection

An initial state is compatible interface and starts IEEE1284.4 communication when magic strings (1284.4 synchronous commands) are received.

#### On

An initial state is IEEE1284.4 communication and data that received it by the time it is able to take synchronization by magic string (1284.4 synchronous commands) is discarded.

#### Off

An initial state is compatible interface and never starts IEEE1284.4 communication even if magic strings (1284.4 synchronous commands) are received.

### 1.3.7 Printer Language and Emulation

Printer Language: (Stylus COLOR C70)  
 EPSON ESC/P2 expanded raster graphics  
 EPSON Remote

(Stylus COLOR C80)  
 ESC/P2 and expanded raster graphics code  
 EPSON Remote command

#### 1.3.7.1 Control codes

□ ESC/P2 control codes

**Table 1-11. ESC/P2 control codes (Stylus COLOR C70)**

General operation	Initialize Printer	ESC @
Paper feeding	Form Feed Line Feed Carriage Return	FF LF CR

**Table 1-12. ESP/P2 control codes (Stylus COLOR C80)**

General operation	Initialize Printer Unidirectional Printing CSF Mode Control	ESC @ ESC U ESC EM
Paper feeding	Form Feed Line Feed Line Spacing Carriage Return	FF LF ESC 0, ESC 2, ESC 3, ESC + CR
Page format	Page Length Left / Right Margin Top / Bottom Margin	ESC (C, ESC C, ESC C0, ESC (S ESC Q, ESC I ESC (c, ESC N, ESC O
Print position motion	Horizontal Print Position Vertical Print Position Tab Horizontally Tab Vertically Advance paper	ESC \$, ESC ¥ ESC (V, ESC (v ESC D, HT ESC B, VT ESC J

**Table 1-12. ESP/P2 control codes (Stylus COLOR C80) (continued)**

Font selection	Typeface Pitch and Point Pitch Italic font Bold Font Master Select	ESC k, ESC x ESC X ESC P, ESC M, ESC g, ESC p ESC 4, ESC 5 ESC E, ESC F ESC !
Font enhancement	Double-Width Condensed Double-height Double-Strike Super / Subscript Underline Line / Score Character Style	ESC W, DC4, SO DC2, SI ESC w ESC G, ESC H ESC T, ESC S ESC - ESC(- ESC q
Spacing	Intercharacter Space HMI Define Unit	ESC Space ESC c ESC (U
Character handling	Character Table International Character User-Defined Characters Upper Control Codes Print Data as characters	ESC t, ESC (t ESC R ESC %, ESC &, ESC : ESC 6, ESC 7 ESC (^
Bit image	Bit Image	ESC
Color	Printing Color	ESC r (Black )
EEPROM control	EEPROM control	ESC



□ Control codes for graphics mode

**Table 1-13. Control codes for graphics mode**

General operation	Initialize Printer Unidirectional Printing CSF Mode Control	ESC @ ESC U ESC EM
Paper feeding	Form Feed Line Feed Line Spacing Carriage Return	FF LF ESC + CR
Page format	Page Length Top / Bottom Margin Paper size	ESC (C ESC (c ESC (S
Print position motion	Horizontal Print Position Vertical Print Position	ESC \$, ESC ¥, ESC (\$, ESC (/ ESC (V, ESC (v
Spacing	Define Unit	ESC (U
Graphics	Graphics Mode Raster Graphics Dot size control Print a Image Microweave control (Stylus COLOR C80 )	ESC (G ESC ., ESC (D, ESC i ESC (e ESC ACK  ESC (i
Printing mode	Printing mode	ESC (K
Color	Printing Color	ESC r, ESC (r

**1.3.7.2 EPSON D4 control channel commands**

The details of each command refer to 1284.4 control command specifications (DS-716).

□ Command List

**Table 1-14. Command List**

Contents	Command	m1
Reply Device ID	di	-
Reply Status string	st	-
Reply Cartridge Position	cx	-
Reply Ink Cartridge condition	cs	0x00, 0x01
Exchange Ink Cartridge	xi	0x01, 0x80
Execute Cleaning	ch	0x01
Print Nozzle check pattern	nc	-
Terminate Ink-exchange Sequence	ei	0x00
Reply CSIC Information	ii	0x01, 0x02, 0x03, 0x04
Set Printer timer (Stylus COLOR C70 )	ti	m1 (*1)
Clear Paper Out Error	pe	0x01
Clear Paper Jam Error	pj	0x01
Reply Ink-exchange flag	ex	Com Num = 0x19
Initialize Printer	rs	0x01
Reply number of printable sheet	ir	0x80

NOTE: (\*1) parameters indicate a time (Stylus COLOR C70 only)

Parameter	Mean	Note
m1, m2,	year	year = m2 x 256 +m1
m3	month	1 <= m3 <= 12
m4	day	1 <= m4 <= 31
m5	hour	0 <= m5 <= 24
m6	minute	0 <= m6 <= 60
m7	second	0 <= m7 <= 60

□ Reply Printer State

The printer sends one of six string shown below that indicates current printer state periodically (set by a BDC-PS command. by default, 2 seconds.).

Format of reply strings:

```
@BDC [SP] ST [CR] [LF]
ST:<Status Code>;
ER:<Error Code>;
[WR:<Warning Code>[,<Warning Code>]...;]
IQ:<nn1><nn2><nn3><nn4>;
RV;<n>;
AI;CW:02<KK><CC><MM><YY>,MI:<mm>;
[TC:<TTTT>;]
INK:1101,3202,4304,5408;IG:0108NA;
[FF]
```

■ Status Codes

The parameter <Status Code>is two bytes of ASCII codes that indicates printer status.

Table 1-15. Status Codes

Status	Status code	Priority
Error	"00"	1
Self-test	"01"	1
Busy (buffer full)	"02"	4
Wait (printing)	"03"	5
Idle	"04"	6
Cleaning/fill up	"07"	2
Before Initialize fill up	"08"	1

■ Error Codes

The parameter <Error Code> is two bytes of ASCII codes that indicates following errors of a printer.

Table 1-16. Error Codes

Error Code	Printer State
"00"	Fatal Error
"01"	I/F not select Error
"04"	Paper jam Error
"05"	Ink Out Error
"06"	Paper Out Error
"10"	Maintenance request
"12"	Double Feed Error

- Quantity of ink  
The parameter <nn1>, <nn2>, <nn3>, <nn4> are two bytes ASCII codes that indicate quantity of black ink, cyan ink, magenta ink and yellow ink respectively.  
If the ink cartridge is not inserted, <nnx> indicates “NA”.  
The unit of these parameters is percentage in hex-decimal.
- Warning Codes  
The parameter <Warning Code> is two bytes of ASCII codes that indicates printer status

**Table 1-17. Warning Codes**

WR	Ink state
“10”	Black ink low
“11”	Cyan ink low
“12”	Magenta ink low
“13”	Yellow ink low

- Firmware revision  
The parameter <n> is one bytes ASCII codes that indicate printer firmware revision.
- Actuator information  
The parameter <KK>, <CC>, <MM>, <YY> are two bytes ASCII codes that indicate ink weight rank ID of black ink, Cyan ink, magenta ink and yellow ink respectively.  
The parameter <mm> is two bytes ASCII codes that indicate Select-Microweave ID to determine the feed length of Microweave printings.
- Cleaning time information  
The parameter <TTTT> is four bytes ASCII codes that indicate total time of cleaning or charging sequences in second unit.  
This character strings is displayed only during cleaning or charging. (Status code of “07”)
- MIB information  
INK parameter shows the ink cartridge information for MIB.  
IG parameter shows the auto sheet feeder information for MIB.

## 1.4 OPERATOR CONTROLS

### 1.4.1 Operate Switch

Operate switch is located on the control panel.

### 1.4.2 Control Panel

#### 1.4.2.1 Switches

There are 2 non-lock type push switches, 1 lock type push switch and 3 LED.

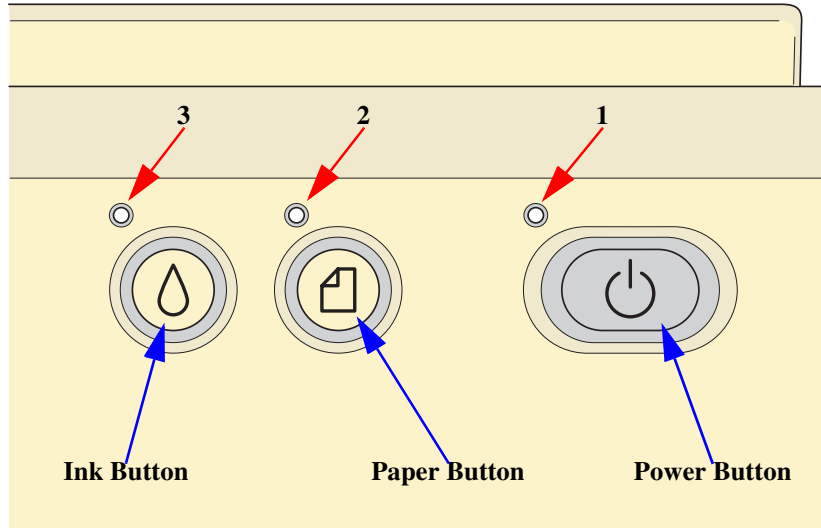

Figure 1-5. Control Panel

#### 1.4.2.2 Indicators

- (1) **Power**  
Lights when the operate switch is “ON” and AC power is supplied.
- (2) **Paper Out**  
Lights during the paper-out condition, and blinks during the paper-jam condition.
- (3) **Ink Out**  
Lights during no ink condition, and blinks during the ink low condition.

### 1.4.3 Panel Functions

**Table 1-18. Panel Functions(Stylus COLOR C70)**

Switch	Function
Load/Eject	<ul style="list-style-type: none"> <li>Loads or Ejects the Paper.</li> <li>When carriage is on the Ink check position, move carriage to next ink check position or cartridge change position.</li> <li>When carriage is on the ink cartridge change position, return carriage from Ink Cartridge change position.</li> <li>In the condition of 'Double Feed Error', Returning from error condition printing is restarted.</li> </ul>
Cleaning	<ul style="list-style-type: none"> <li>Starts the Ink Cartridge change sequence. (*2) Move the carriage to cartridge change position.</li> <li>When carriage is on the ink change position, move carriage to next ink check position or cartridge change position.</li> <li>When carriage is on the ink change position, return carriage from ink cartridge change position.</li> </ul>
Cleaning (Pushing for 2 seconds *1)	<ul style="list-style-type: none"> <li>Starts the cleaning of head.</li> <li>In the condition of 'Ink Low' or 'Ink Out' or 'No Ink Cartridge', starts the ink cartridge change sequence. (*2)</li> </ul>

**NOTE:** (\*1) 3 seconds is required at the User's manual.

**NOTE:** (\*2) This function is not available in printing status.

**Table 1-19. Panel Functions with Power On(Stylus COLOR C70)**

Switch	Pressing with Power on Function
Load/Eject	<ul style="list-style-type: none"> <li>Start status printings.* (*1)</li> </ul>
Load/Eject + Cleaning	<ul style="list-style-type: none"> <li>Enters the particular settings mode. (Service use only.) To enter the particular settings mode, it is necessary to push following switch while Paper Out LED is blinking. (It blinks about 5 seconds.) (*3)</li> </ul>

**Table 1-20. Panel Functions with Power On(Stylus COLOR C80)**

Switch	Pressing with Power on Function
Paper	<ul style="list-style-type: none"> <li>Start status printings.* (*1)</li> </ul>
Ink	<ul style="list-style-type: none"> <li>Enters the user setting mode.</li> </ul>
Paper + Ink	<ul style="list-style-type: none"> <li>Enters the particular setting mode (Service use only). To enter the particular settings mode, it is necessary to push following switch while Paper Out LED is blinking. (It blinks about 5 seconds.) (*3)</li> </ul>

**NOTE:** (\*) Status printings prints firmware version, ink counter and nozzle check patterns.

**NOTE:** (\*1) According to the content of 1 BH of EEPROM, one of following actions is carried out.

**Table 1-21. The Content of 1 BH of EEPROM**

Content of 1BH of EEPROM, [bit 7][bit 6]	Action
00	<ul style="list-style-type: none"> <li>Print firmware version, ink counter, selected code page and nozzle check pattern</li> </ul>
11	
01	<ul style="list-style-type: none"> <li>Start hex-dump printing</li> </ul>
10	<ul style="list-style-type: none"> <li>Start self test printing</li> </ul>

**Table 1-22. User settings mode (Stylus COLOR C80 only)**

Switch	Function
Paper	<ul style="list-style-type: none"> <li>Enters the default setting mode. (*1)</li> </ul>
Ink	<ul style="list-style-type: none"> <li>Enters the print head alignment mode. (*2)</li> </ul>

**NOTE:** (\*1) Refer to 1.4.5.1 Default setting.

**NOTE:** (\*2) Refer to 1.4.5.2 Print head alignment.

**Table 1-23. Particular settings mode (Stylus COLOR C70)**

Switch	Function
Load/Eject	• Initialize EEPROM. (*3)
Cleaning (Pushing for 10 seconds)	• Reset the ink overflow counter in EEPROM. (*3)

**Table 1-24. Particular settings mode (Stylus COLOR C80)**

Switch	Function
Paper	• Initialize EEPROM (*3) and rest timer IC.
Ink (Pushing for 10 seconds)	• Reset the ink overflow counter in EEPROM. (*3)

**NOTE:** (\*3) Refer to Chapter 7 EEPROM map.

## 1.4.4 Printer Condition and Panel Status

**Table 1-25. Printer Condition and LED Status**

Printer Status	Indicators			Priority
	Power	Ink Out	Paper Out	
Power ON condition	On	-	-	10
Ink sequence	Blink	-	-	6
Ink Cartridge change mode	Blink	-	-	5
Data processing	Blink	-	-	8
Paper Out	-	-	On	4
Double feed	-	-	On	4
Paper jam condition	-	Off	Blink	3
No ink cartridge or ink end	-	On	-	7
Ink level low	-	Blink	-	9
Enter EEPROM and Timer IC reset	-	On	On	-
Maintenance request	Blink	Blink	Blink	2
Fatal error	Blink	On	Blink	1

**NOTE:** (-) Don't care.

The reason why possible causes of paper out and double feed errors are listed together is because double feeding during duplex printing can cause problems with page numbering and render the whole printing job useless, so that if it is judged that the paper is longer than the normal length, the current page is fully ejected, and then a paper out error is indicated straight away to prompt the customer to reset the paper. Furthermore, it is also assumed that such double-feed errors will result in the paper running out before the last page or the last few pages are printed, and so double feed and paper out errors are handled in the same way. This is considered to be a refinement of conventional paper jam detection.

### 1.4.5 Printer setting mode (Stylus COLOR C80 only)

When turning the printer on with pushing the Cleaning switch, the Paper Out LED starts blinking. Then, to pushing the Load /Eject switch again while the Paper Out LED is blinking, or no switch pushing while the Paper Out LED is blinking, the printer enters the Default setting mode.

To pushing the Cleaning switch while the Paper Out LED is blinking, the printer enters the Print head alignment mode.

#### 1.4.5.1 Default setting mode

There are some parameters that can be changed by users and will be referred at the time of initialization of the printer.

Setting method

- (a) Press Load/Eject button.  
The method of selecting language for ‘Usage of this mode’ is printed.
- (b) Select language for ‘Usage of this mode’ by Cleaning button.  
Paper Out LED, Ink Out LED and Power LED show the language for ‘Usage of this mode’ that is currently selected. The selection will be advanced one by one as the button is pressed and the On/Off/Blink of those three LEDs will also be changed according to the selection.
- (c) Press Load/Eject button.  
The current setting and the ‘Usage of this mode’ by selected language will be printed on the paper set in the paper path at that time.
- (d) Select menu by Cleaning button.  
Paper Out LED, Ink Out LED and Power LED show the menu which is selected at that time. The selection will be advanced one by one as the button is pressed and the combination of those three LEDs status of On/Off/Blink/2-Blinks will be changed according to the selection.
- (e) When Load/Eject button is pressed, Printer changes the indication to the setting value of the selected menu.  
Paper Out LED , Ink Out LED and Power LED show the current setting value.
- (f) Select setting value by Load/Eject button.  
Paper Out LED, Ink Out LED and Power LED show that menu’s value by status of On/Off/Blink/2-Blinks.  
That value can be changed by pressing Load/Eject button and the LEDs status of On/Off/Blink/2-Blinks will be changed as the button is pressed.

- (g) When Cleaning button is pressed, Printer memorize the setting value, and changes the indication to the main menu.  
Paper Out LED, Ink Out LED and Power LED show the current menu setting.
- (h) Repeat (d) to (g)  
The menu selection will return to the first menu after the last menu selection is over.
- (i) Turn the printer off  
The setting is stored into non-volatile memory.

Table 1-26. Setting Menu

Menu	Setting			
Font	Roman / Courier / Draft			
Print direction	Auto / Bi-D / Uni-D			
Loading Position	3 mm / 8.5 mm / Others			
Parallel I/F transfer rate	Fast / Normal			
Auto line feed	Off / On			
0 slash	0 / ø			
Pitch	10 cpi, 12 cpi, 15 cpi, 17 cpi, 20 cpi, Proportional			
Character tables	<table border="0"> <tr> <td>Italic USA, Italic Germany, Italic Denmark, Italic Italy, PC 437, PC 850, PC 855, PC 857, PC 869, Code MJK. ISO Latin 1T, PC 774, ISO 8859-2, PC 860, PC 865, PC AR864, PC 708, BRASCII, ISO Latin1</td> <td>                     Italic France, Italic U.K., Italic Sweden, Italic Spain, PC 437 Greek, PC 853, PC 852, PC 866, MAZOWIA, ISO 8859-7, Bulgaria, Estonia, PC 866 LAT, PC 861, PC 866 UKR, PC APTEC, PC 720, Abicomp, Roman 8                 </td> <td>                     PC 858. ISO 8859-15, PC 863, PC 861, PC 771,                 </td> </tr> </table>	Italic USA, Italic Germany, Italic Denmark, Italic Italy, PC 437, PC 850, PC 855, PC 857, PC 869, Code MJK. ISO Latin 1T, PC 774, ISO 8859-2, PC 860, PC 865, PC AR864, PC 708, BRASCII, ISO Latin1	Italic France, Italic U.K., Italic Sweden, Italic Spain, PC 437 Greek, PC 853, PC 852, PC 866, MAZOWIA, ISO 8859-7, Bulgaria, Estonia, PC 866 LAT, PC 861, PC 866 UKR, PC APTEC, PC 720, Abicomp, Roman 8	PC 858. ISO 8859-15, PC 863, PC 861, PC 771,
Italic USA, Italic Germany, Italic Denmark, Italic Italy, PC 437, PC 850, PC 855, PC 857, PC 869, Code MJK. ISO Latin 1T, PC 774, ISO 8859-2, PC 860, PC 865, PC AR864, PC 708, BRASCII, ISO Latin1	Italic France, Italic U.K., Italic Sweden, Italic Spain, PC 437 Greek, PC 853, PC 852, PC 866, MAZOWIA, ISO 8859-7, Bulgaria, Estonia, PC 866 LAT, PC 861, PC 866 UKR, PC APTEC, PC 720, Abicomp, Roman 8	PC 858. ISO 8859-15, PC 863, PC 861, PC 771,		

### 1.4.5.2 Print head alignment mode

Some alignment can be adjusted by users.

#### □ Alignment method

- (a) Press Cleaning button.  
The method of selecting language for 'Usage of this mode' is printed.
- (b) Select language for 'Usage of this mode' by Cleaning button.  
Paper Out LED, Ink Out LED and Power LED show the language for 'Usage of this mode' that is currently selected. The selection will be advanced one by one as the button is pressed and the On/Off/Blink of those three LEDs will also be changed according to the selection.
- (c) Press Load/Eject button.  
Printer prints the instruction sheets on how to adjust the printer.
- (d) Look at the tests printed along with the instruction and press the Cleaning button until the panel lights indicate the appropriate test number.
- (e) Press Load/Eject button. Then, printer prints the test pattern.
- (f) Look at the test patterns on the new printout and press the Load/Eject button until the panel lights indicate the test pattern that is most closely aligned.
- (g) Press the Cleaning button.
- (h) Follow step (d) to step (g) as many times as needed to properly align all the test patterns on the printouts.
- (i) Turn the printer off.

### 1.4.6 Printer Initialization

There are three kinds of initialization method.

1. Power-on Initialization  
This printer is initialized when turning the printer power on, or printer recognized the cold-reset command (remote RS command).

When printer is initialized, following action is performed:

- (a) Initializes printer mechanism.
- (b) Clears input data buffer.
- (c) Clears print buffer.
- (d) Sets default values.

2. Operator Initialization  
This printer is initialized when turning the printer power on again within 10 seconds from last power off, or printer recognized the -INIT signal (negative pulse) of parallel interface.

When printer is initialized, following action is performed:

- (a) Cap the printer head.
- (b) Eject a paper.
- (c) Clears input data buffer.
- (d) Clears print buffer.
- (e) Sets default values.

3. Software Initialization  
The ESC@ command also initialize the printer.

When printer is initialized, following action is performed:

- (a) Clears print buffer.
- (b) Sets default values.

4. Power-on initialization except I/F  
The printer recognized the IEEE 1284.4 "rs" command.

When printer is initialized, following action is performed.

- (a) Initializes printer mechanism.
- (b) Clears input data buffer.
- (c) Clears print buffer.
- (d) Sets default values except I/F.



## 1.4.7 Errors

- Ink Out**

When the printer runs out the most part of the ink of any color, it warns ink-low and keeps printing. When the printer runs out the whole ink of any one color, it stops printing and indicates ink-out error. User is requested to install a new ink-cartridge in this state. An ink-cartridge once taken out should never be used again. Re-installation of the cartridge not filled fully upsets the ink level detection and may cause a serious problem in the print head as a result.
- Paper Out**

When printer fails to load a sheet, it goes paper out error.
- Paper Jam**

When printer fails to eject a sheet, it goes a paper jam error.
- No Ink-Cartridge**

When printer detects that ink-cartridge comes off, it goes this error mode.
- Maintenance Request**

When the total quantity of ink wasted through the cleanings and flushing is reaches to the limit, printer indicates this error and stops. The absorber in the printer enclosure is needed to be replaced with new one by service person.
- Fatal Errors**

Carriage control error or CG access error.
- Double Feed**

When printer fails to load a sheet, it goes Double feed error.

## 1.5 PAPER

### 1.5.1 Paper Handling

Do not perform reverse feed more than 9.5 mm (0.38”).

### 1.5.2 Paper Specification

#### 1.5.2.1 Cut Sheet

**Table 1-27. Paper Specification (Cut Sheet)**

Size	A4: Width 210 mm x Length 297 mm Letter: Width 216 mm x Length 279 mm B5: Width 182 mm x Length 257 mm Legal: Width 216 mm x Length 356 mm Statement: Width 139.7 mm x Length 215.9 mm Executive: Width 184.2 mm x Length 266.7 mm Photo Paper: Width 101.6 mm x Length 152.4 mm
Thickness	0.08mm - 0.11mm
Weight	64g/m <sup>2</sup> (17 lb.) - 90g/m <sup>2</sup> (24 lb.)
Quality	Exclusive paper, Bond paper, PPC

#### 1.5.2.2 Envelope

**Table 1-28. Paper Specification (Envelope)**

Size	No.10: Width 241 mm x Length 104.8 mm DL: Width 220 mm x Length 110 mm C6: Width 162 mm x Length 114 mm
Thickness	0.16mm - 0.52mm
Weight	45g/m <sup>2</sup> (12 lb.) - 75g/m <sup>2</sup> (20 lb.)
Quality	Bond paper, Plain paper, Air mail

*NOTE: Envelope printing is only available at normal temperature.*

*NOTE: Keep the longer side of the envelope horizontally at setting.*

#### 1.5.2.3 Index Card

**Table 1-29. Paper Specification (Envelope)**

Size	A6 Index Card: Width 105 mm x Length 148 mm A5 Index Card: Width 148 mm x Length 210 mm 5 x 8” Index Card: Width 127 mm x Length 203 mm 10 x 8” Index Card: Width 254 mm x Length 203 mm
Thickness	Less than 0.23 mm

**1.5.2.4 EPSON special media**

□ EPSON specifically designed media for ink jet printers

(1) Bright White ink Jet Paper

**Table 1-30. Bright White ink Jet Paper**

Size	A4: Width 210 mm x Length 297 mm
Thickness	0.13 mm
Weight	92.5 g/m <sup>2</sup> (25 lb)

(2) 360 dpi Ink Jet Paper

**Table 1-31. 360 dpi Ink Jet Paper**

Size	A4: Width 210 mm x Length 297 mm Letter: Width 215.9 mm x Length 279.4 mm
Thickness	0.11 mm
Weight	89 g/m <sup>2</sup> (24 lb)

(3) Matte Paper-Heavyweight

**Table 1-32. Matte Paper-Heavyweight**

Size	A4: Width 210 mm x Length 297 mm Letter: Width 215.9 mm x Length 279.4 mm
Thickness	0.23 mm
Weight	167 g/m <sup>2</sup> (44 lb)

(4) Archival Matte Paper

**Table 1-33. Archival Matte Paper**

Size	A4: Width 210 mm x Length 297 mm Letter: Width 215.9 mm x Length 279.4 mm
Thickness	0.25 mm
Weight	189 g/m <sup>2</sup> (50 lb)

(5) Premium Glossy Photo Paper

**Table 1-34. Premium Glossy Photo Paper**

Size	A4: Width 210 mm x Length 297 mm Letter: Width 215.9 mm x Length 279.4 mm
Thickness	0.27 mm
Weight	255 g/m <sup>2</sup> (68 lb)

(6) Premium Semigloss Photo Paper

**Table 1-35. Premium Semigloss Photo Paper**

Size	A4: Width 210 mm x Length 297 mm Letter: Width 215.9 mm x Length 279.4 mm
Thickness	0.27 mm
Weight	250 g/m <sup>2</sup> (66 lb)

(7) Ink Jet Transparencies

**Table 1-36. Bright White ink Jet Paper**

Size	A4: Width 210 mm x Length 297 mm Letter: Width 215.9 mm x Length 279.4 mm
Thickness	0.13 mm

(8) Photo Stickers 4/16

**Table 1-37. Photo Stickers 4/16**

Size	A6: Width 105 mm x Length 148 mm
Thickness	0.19 mm

(9) Iron-On Cool Peel Transfer Paper

**Table 1-38. Iron-On Cool Peel Transfer Paper**

Size	A4: Width 210 mm x Length 297 mm Letter: Width 215.9 mm x Length 279.4 mm
Thickness	0.18 mm

### 1.5.3 Printing Area

#### 1.5.3.1 Cut Sheet

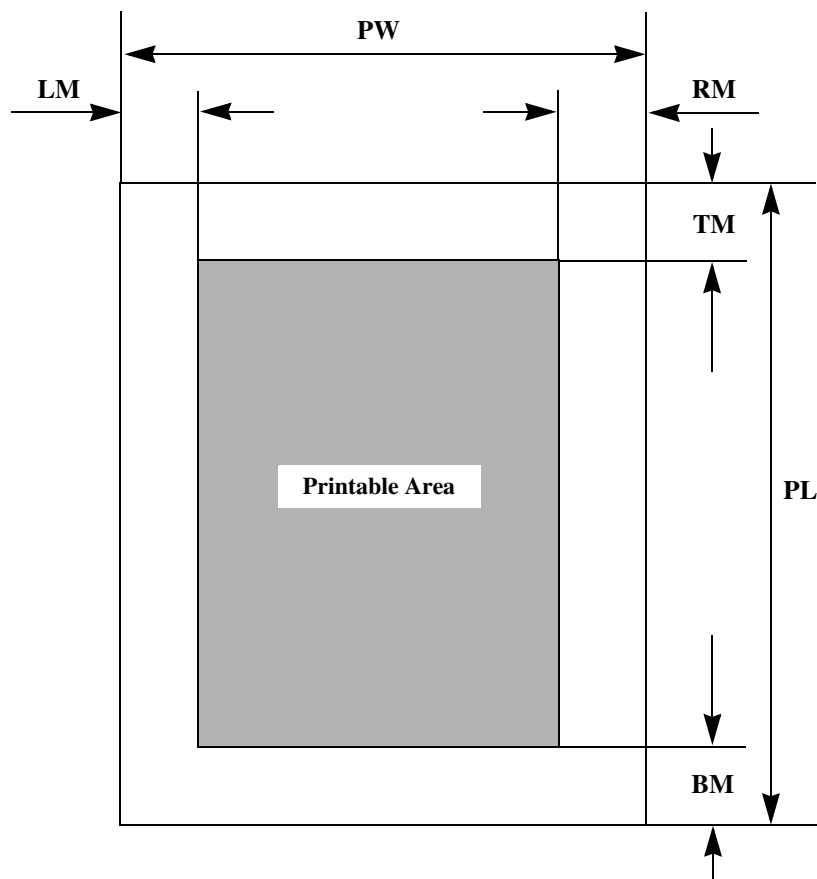

Figure 1-6. Printable Area for Cut Sheet

NOTE: Refer to 1.5.2 PW (paper width) and PL (paper length)

Table 1-39. Character mode

Paper Size	Left margin (min.)	Right Margin (min.)	Top Margin (min.)	Bottom Margin (min.)
A4	3 mm (0.12")	3 mm (0.12")	3 mm (0.12")	14 mm (0.54")
Letter	3 mm (0.12")	9 mm (0.35")	3 mm (0.12")	14 mm (0.54")
B5	3 mm (0.12")	3 mm (0.12")	3 mm (0.12")	14 mm (0.54")
Legal	3 mm (0.12")	9 mm (0.35")	3 mm (0.12")	14 mm (0.54")
Statement	3 mm (0.12")	3 mm (0.12")	3 mm (0.12")	14 mm (0.54")
Exclusive	3 mm (0.12")	3 mm (0.12")	3 mm (0.12")	14 mm (0.54")

Table 1-40. Raster Graphics mode

Paper Size	Left margin (min.)	Right Margin (min.)	Top Margin (min.)	Bottom Margin (min.)
A4	3 mm (0.12")	3 mm (0.12")	3 mm (0.12")	14 mm (0.54") / 3mm (0.12") *
Letter	3 mm (0.12")	3 mm (0.12")	3 mm (0.12")	14 mm (0.54") / 3mm (0.12") *
B5	3 mm (0.12")	3 mm (0.12")	3 mm (0.12")	14 mm (0.54") / 3mm (0.12") *
Legal	3 mm (0.12")	3 mm (0.12")	3 mm (0.12")	14 mm (0.54") / 3mm (0.12") *
Statement	3 mm (0.12")	3 mm (0.12")	3 mm (0.12")	14 mm (0.54") / 3mm (0.12") *
Executive	3 mm (0.12")	3 mm (0.12")	3 mm (0.12")	14 mm (0.54") / 3mm (0.12") *

NOTE: (\*)Bottom margin is expanded to 3mm when paper dimension is defined by using command, otherwise it is not expanded (14mm).

NOTE: From a form lower end 3 mm as for 14 mm area a printing may scramble.

1.5.3.2 Envelopes

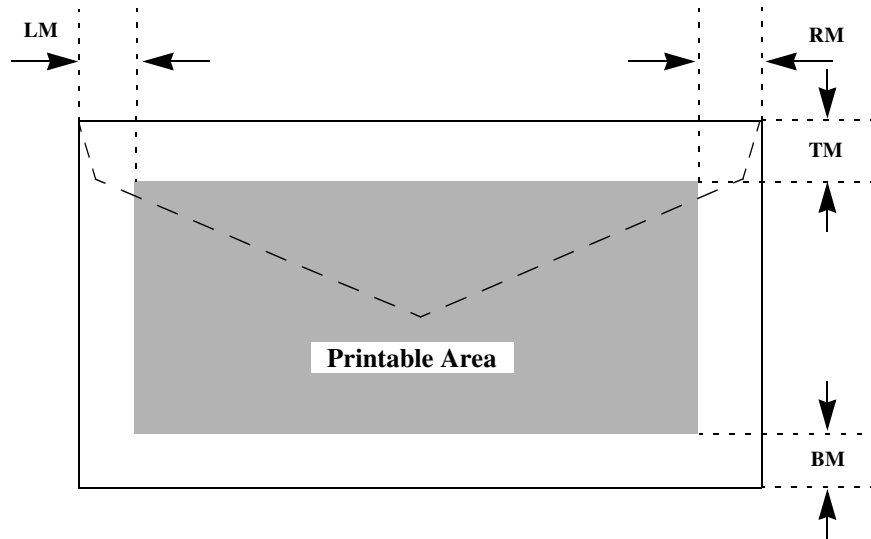

Figure 1-7. Printable Area for Envelopes

Table 1-41. Envelope Margin

Paper Size	Left Margin (min.)	Right Margin (min.)	Top Margin (min.)	Bottom Margin (min.)
#10	3 mm (0.12")	28 mm (1.10")	3 mm (0.12")	14 mm (0.55")
DL	3 mm (0.12")	7 mm (0.28")	3 mm (0.12")	14 mm (0.55")
C6	3 mm (0.12")	3 mm (0.12")	3 mm (0.12")	14 mm (0.55")

## 1.6 INK CARTRIDGE

### 1.6.1 Black Ink Cartridge

Type: Exclusive Cartridge  
 Color: Black  
 Print Capacity: 1240 pages/A4  
 (ISO/IEC 10561 Letter Pattern at 360 dpi)  
 Ink Life: 2 years from production data.  
 Storage Temperature: -20 °C to 40 °C (Storage, within a month at 40 °C)  
 -30 °C to 40 °C (Packing storage, within a month at 40 °C)  
 -30 °C to 60 °C (Transit, within 120 hours at 60 °C  
 and within a month at 40 °C)  
 Dimension: 22.0 mm (W) x 71.2 mm (D) x 66.5 mm (H)

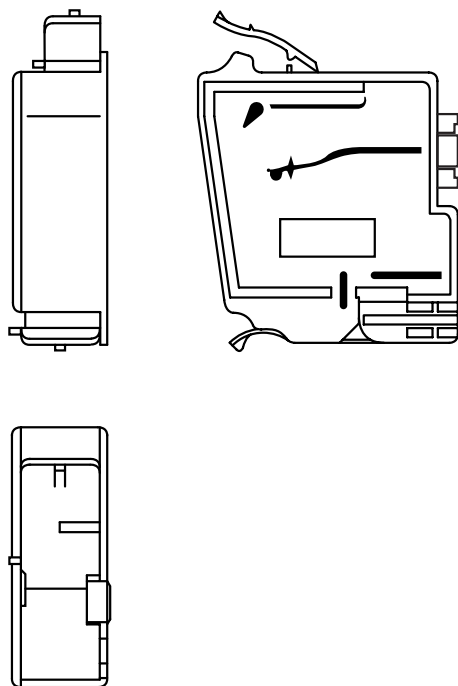

Figure 1-8. Black Ink Cartridge

### 1.6.2 Color Ink Cartridge

Type: Exclusive Cartridge  
 Color: Magenta, Cyan, Yellow  
 Print Capacity: 420 pages / A4 (360 dpi, 5% duty each color)  
 Ink Life: 2 years from production date  
 Storage Temperature: -20 °C to 40 °C (Storage, within a month at 40 °C)  
 -30 °C to 40 °C (Packing storage, within a month at 40 °C)  
 -30 °C to 60 °C (Transit, within 120 hours at 60 °C  
 and within a month at 40 °C)  
 Dimension: 12.7 mm (W) x 71.2 mm (D) x 66.5 mm (H)

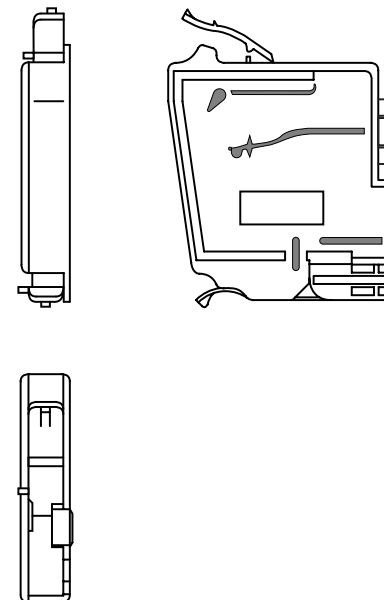

Figure 1-9. Color Ink Cartridge

**NOTE:** Ink cartridge can not re-fill, only ink cartridge is prepared for article of consumption.

**NOTE:** Do not use the ink cartridge which was passed away the ink life.

**NOTE:** Ink will be frozen under -4 °C environment however, it will be usable after placing it more than 3 hours at room temperature.

CHAPTER

2

# OPERATING PRINCIPLES

## 2.1 Overview

This section describes the operating principles of the printer mechanism and electrical circuit boards. The Stylus COLOR C70/C80 has the following boards:

- Main board: C424 MAIN-B

**NOTE:** There is no part with the name C424 Main in current products. The C424 Main-B board in the Stylus C70 and C80 has a different name, and so is not exactly the same part. The parts code for ordering is also different.

- Power supply board: C424 PSB/PSE

### 2.1.1 Printer Mechanism

The printer mechanism for Stylus COLOR C70/C80 is designed newly. But, the basic component of the printer mechanism is same as previous product.

This printer consists of Print Head, Carriage Mechanism, Paper Feeding Mechanism, Paper Loading Mechanism, Ink System (Pump Mechanism, Cap Mechanism, and Carriage Lock Mechanism).

Like other EPSON ink jet printers, the Stylus COLOR C70/C80 is equipped with two DC motors; one for ASF, Paper feeding/ Pump mechanism, and one for CR mechanism. ASF unit uses rear entry front eject system. This ASF unit is also designed newly and LD roller loads the paper to the printer mechanism.

For cap assembly, Stylus COLOR C70/C80 uses valveless mechanism; new design for this model.

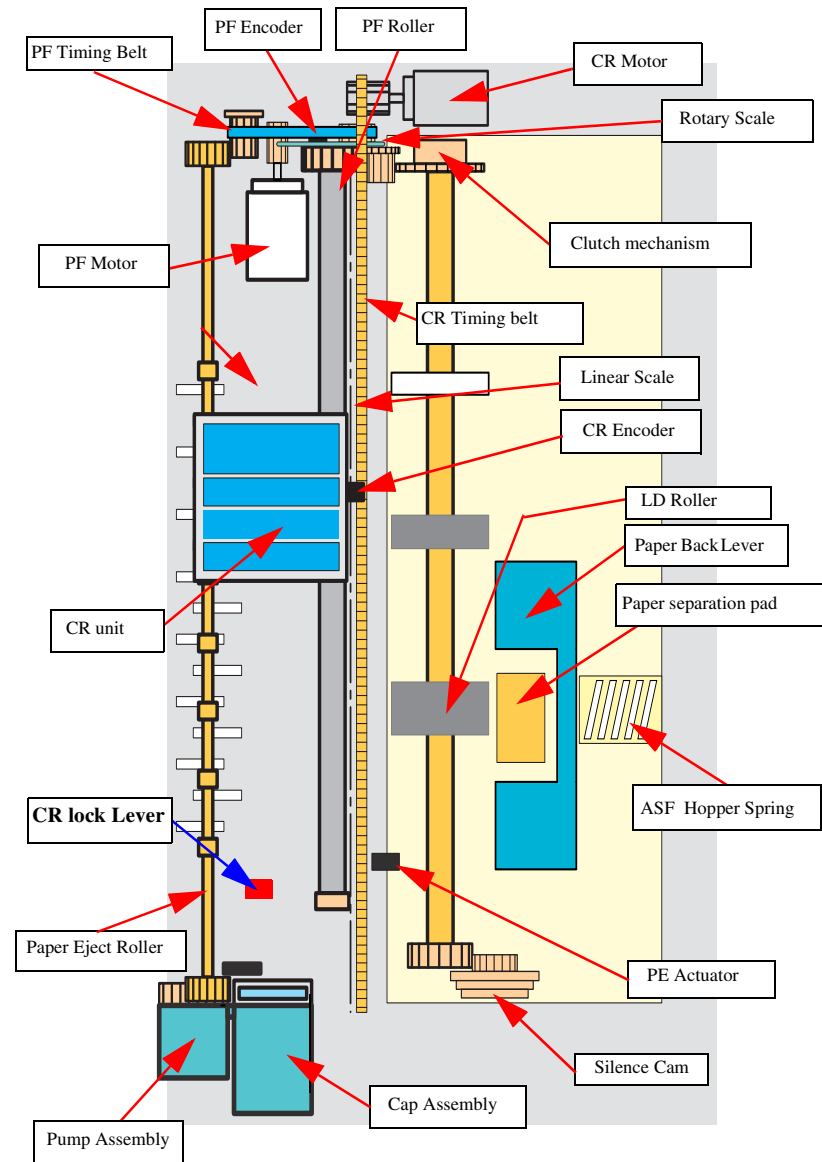

Figure 2-1. Printer Mechanism block diagram



## 2.1.2 Printhead

The printhead uses a new developed P-MACH head and Stylus COLOR C70/C80 can perform variable dot printing.

The CSIC-chip is mounted on the ink cartridge. By storing ink life data, this IC makes it possible to control the ink in ink cartridge unit.

The basic operating principles of the printhead, which plays a major role in printing, are the same as previous models; on-demand method which uses PZT (Piezo Electric Element). In order to uniform the amount of ejecting ink, the printhead has its own head ID (13 digits for this printhead) which adjust PZT voltage drive features. The printhead stores the head ID to EEPROM and generates appropriate PZT drive voltage to prevent amount of ink from varying by printheads.

Following explains printhead basic components.

- **PZT**  
PZT is an abbreviation of Piezo Electric Element. Certain amount of voltage expands and contracts PTZ. The drive wave generated on MAIN board drives PZT and PZT pushes the top cavity which has ink stored to discharge the ink from each nozzle on the nozzle plate.
- **Ink Cavity**  
The ink absorbed from the ink cartridge goes through the filter and then is stored temporarily in this tank called “cavity” until PZT is driven.
- **Nozzle Plate**  
The board with nozzle holes on the printhead surface is called Nozzle Plate.
- **Electrodes for CSIC-chip**  
The communication between CSIC-chip and main unit is performing via the electrodes on the carriage.
- **Filter**  
When the ink cartridge is installed, if any dirt or dust around the cartridge needle is absorbed into the head, there is a great possibility of causing nozzle clog and disturbance of ink flow, and finally causing alignment failure and dot missing. To prevent this problem, a filter is set below the cartridge needle, where ink is filtered.

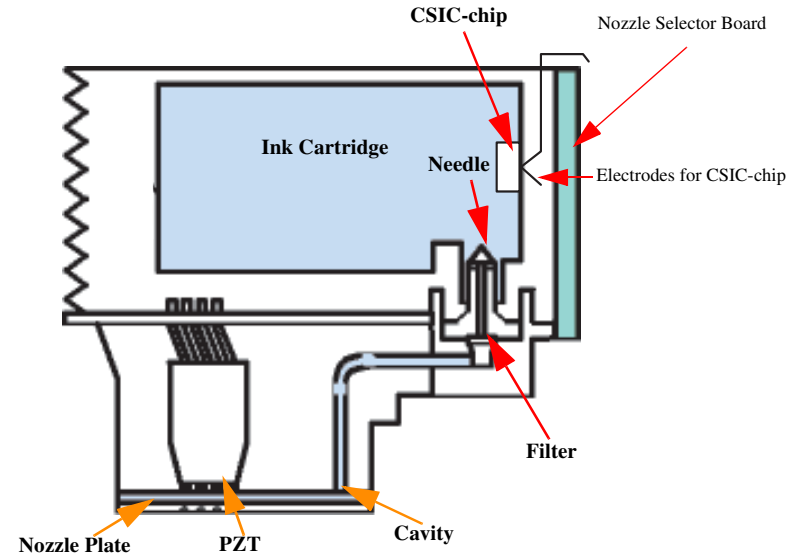

Figure 2-2. Printhead Sectional Drawing (Image)

### 2.1.2.1 Printing Process

This section explains the process in which the printheads of On-Demand inkjet printers eject ink from each nozzle.

- 1) **Normal State:**  
When no printing signal is sent from PC, or no PZT drive voltage is applied, PZT does not change shape, therefore PZT does not squeeze the cavity. Ink pressure inside the cavity is kept normal. (Refer to Figure 2-3.)
- 2) **Ejecting State:**  
When the print signal is output from the C424 MAIN-B board, IC (Nozzle Selector) located on the printhead unit latches data once by 1-byte unit.

An appropriate PZT latched by the nozzle selector is pushed into the cavity by the common voltage applied from the main board. By this operation, ink stored in the cavity spurts out from nozzles. (Refer to Figure 2.1.2.2.)

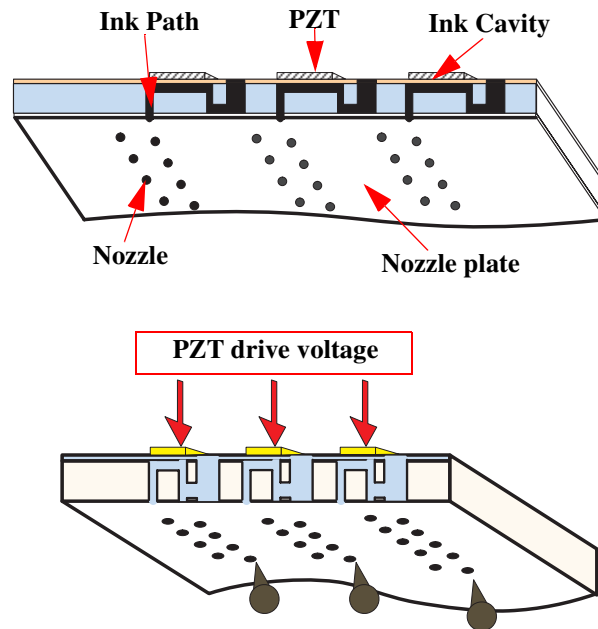

Figure 2-3. Printhead printing process

### 2.1.2.2 Printing Method

For print dot system, Stylus COLOR C70/C80 has the following two kinds of printing modes.

- Economy dot printing
- Variable dot printing (VSD1, VSD2, VSD3. 3types is all.)

The above two dot types are automatically selected depending on the media and the resolution setting of the printer driver. The following explains each printing mode.

- Normal dot printing  
With this printer, Economy dot printing is basically used only during Economy mode printing. The reason is that the resolution is low during Economy mode printing, so that the dot size needs to be bigger. Economy printing consists of 2 shots.
- Variable dot printing  
This printing mode is developed to improve the power of graduation-expression. This mode is basically the same as variable dot printing mode used on other products /; small dot, middle dot, and large dot compose this mode. Print dot size varies according to print data and this mode enables even sharper image output on almost all the papers.

### 2.1.3 Carriage Mechanism

The carriage mechanism consists of Carriage motor (CR motor), Carriage unit (including printhead), CR timing belt, CR guide shaft, CR guide frame etc. In contrast to previous models, this model has no HP sensor, so that when the carriage unit goes out of step at right side, it is judged to be at the home position. The carriage mechanism moves the carriage back and forth according to the drive from the carriage motor. The following stepping motor is mounted to drive CR mechanism. (See the table below.)

**Table 2-1. Carriage Motor Specification**

Items	Specifications
Type	DC motor
Drive Voltage	+42 V +/- 5% (DRV IC voltage)
Coil Resistance	22.3 Ω +/- 15% (per phase at 25 degree)
Inductance	17.3mH +/- 25%(1KH 1VmA)
Drive Method	PWM drive (PWM means Pulse Width Moduration.)
Driver IC	A3974 (Same to PF motor)

The drive from CR motor is transferred to the CR unit via CR timing belt. And the CR home position is detected when firmware judges the carriage is going out of step at right side. Previous products, this printer have the PG adjustment value (1.35mm).

The PG lever selections that can be carried out by the customer are shown in the following table.

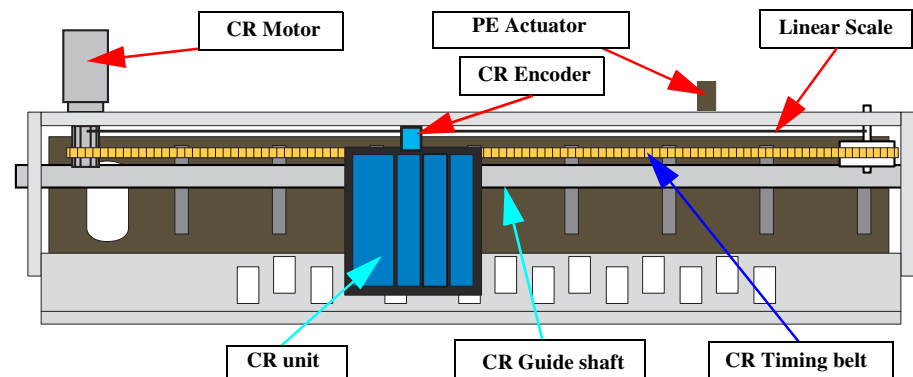

**Figure 2-4. Carriage Mechanism (Top view)**

CR home position is detected by the feed back signal from the Linear Scale. This is normally signal (1), but when the HP is out of step, it becomes (2).

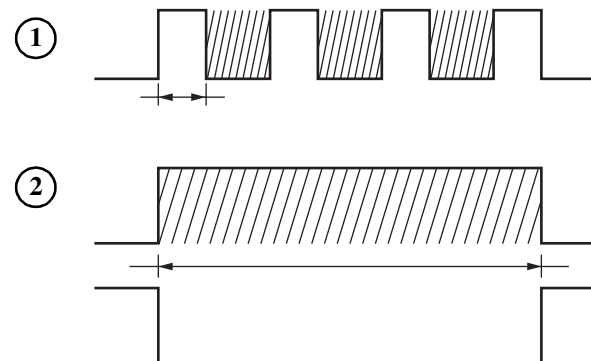

**Figure 2-5. CR home position**

### 2.1.4 Paper Feeding Mechanism

The paper feeding mechanism consists of Paper feed motor (PF motor), PF roller, Paper eject roller, Star wheel roller, and so on. The paper feeding mechanism feeds paper loaded from ASF using the PF roller and Paper Eject Roller & Star wheel roller. For this mechanism, the PF motor mentioned in the right Table 2-2 is used on this product.

The drive of the PF motor is transfer to the PF roller and the Paper Eject Roller as following Figure 2-6. Following shows you how to transfer the PF motor drive to the PF roller and the Paper Eject Roller.

The PF motor has the following three functions: PF/ASF/Pump. Thus cleaning is not possible during printing. If you try to do cleaning while printing is in progress, the current page will first be ejected and then cleaning will start.

Table 2-2. PF Motor Specifications

Item	Description
Motor type	DC motor
Drive voltage	+42 V +/- 5% (DRV IC voltage)
Coil Resistance	22.3 Ω +/- 25% (per phase)
Inductance	17.3 mH +/- 25%(1kHz 1Vrms)
Driving method	PWM drive (PWM means Pulse Width Modulation.)
Driver IC	A3974 (Same to CR motor)

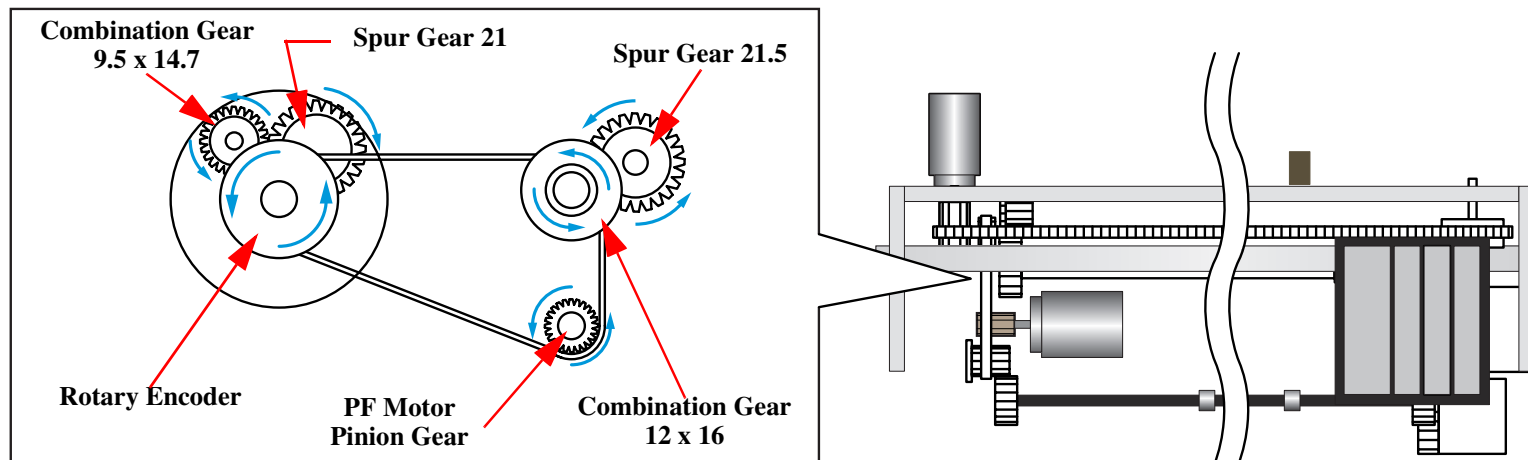

Figure 2-6. Paper Feeding Mechanism

Paper loaded from ASF is advanced by the following roller.

- Paper feed roller & Paper guide roller (assembled on the Top Frame) → Paper eject roller & Star wheel roller (assembled on the Paper eject frame).

Additionally, the top & end of the paper is detected with the PE sensor.

In case the PE sensor dose not detect the paper in the paper loading sequence, the printer detects the "Paper out error". If the paper is detected after complete the paper eject sequence, the printer detects the "Paper jam error".

Also, if the longer paper is detected after complete the paper eject sequence, the printer detects the "Double feed error".

## 2.1.5 Paper Loading Mechanism (ASF Unit)

The Paper loading mechanism is positioned at the printer rear. The Paper loading mechanism loads paper at the ASF unit and feeds paper to the PF roller.

- ASF Support Guide

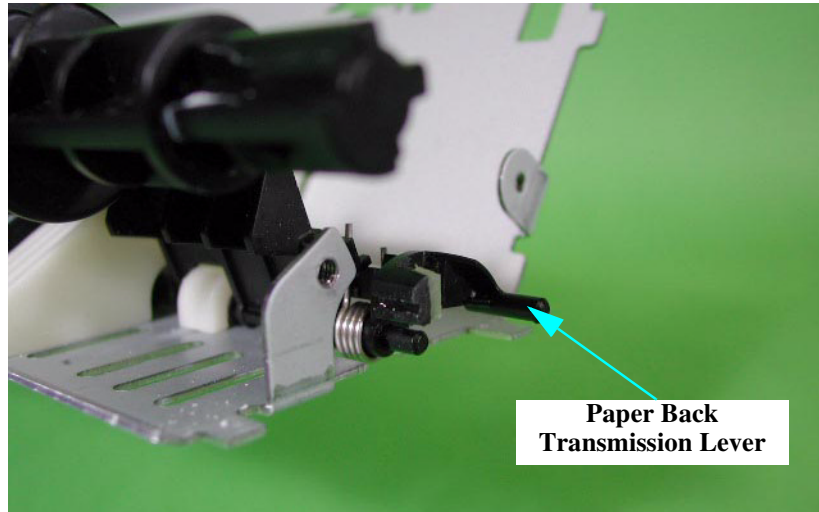

**Figure 2-7. ASF Support Guide**

### Purpose

1. When the specification 150 sheets of plain paper have been set, the customer can generally check whether 150 pages are loaded from the thickness of the ASF marking. However, it can be assumed that some customers might try to force more than 150 sheets in. The ASF guide is shaped like a key so that no more than 150 sheets can be placed into it so as to prevent paper feeding problems. The result is that this key shape encourages the customer to remove the excess number of sheets and to place them back into the hopper.
2. Another purpose of the ASF support guide is that when the paper back lever snaps back into place during paper feeding, the paper back lever also brings the key-shaped ASF support guide back to prevent multiple sheets of paper from being fed at once, thus improving the reliability of paper feeding.

This ASF unit was designed newly for this product and consists of LD roller, Pad holder (Paper return plate), ASF Frame, Hopper, and so on.

For the major feature of this ASF unit, ASF HP sensor is not used and the single LD roller is built in the ASF unit.

Drive sent from the PF motor is always transmitted to the ASF unit side. But, the Change lever and the Clutch mechanism switch ON/OFF the PF motor drive to the LD roller with the motor rotational direction.

## CLUTCH MECHANISM

The Clutch mechanism is located at the rear of the printer inside the left part of the ASF unit.

Unlike the previous products, this product dose not have a ASF HP sensor. Instead of the ASF HP sensor, Change lever and the Clutch mechanism are used to detect the ASF home position. Following figures describe the mechanism.

### □ Paper feeding

1. When the print data is sent to the printer, paper feeding starts.
2. The Carriage unit moves to the left side of the printer and contacts the Change lever, causing the hook of the Change lever to disengage from the projection on the Clutch.

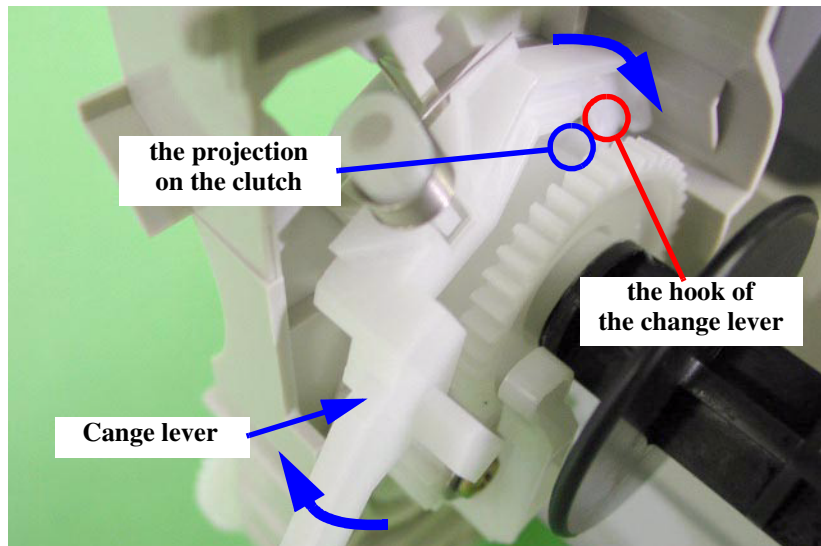

Figure 2-8. Paper feeding (1)

3. The driving force from the PF motor is transmitted via Combination gears 18.4 and 32.8, Spur gear 22.4, Spur gear 12 and Combination gear ratchet 33.4 in that order, causing the clutch and the LD roller to rotate clockwise so that paper is fed.

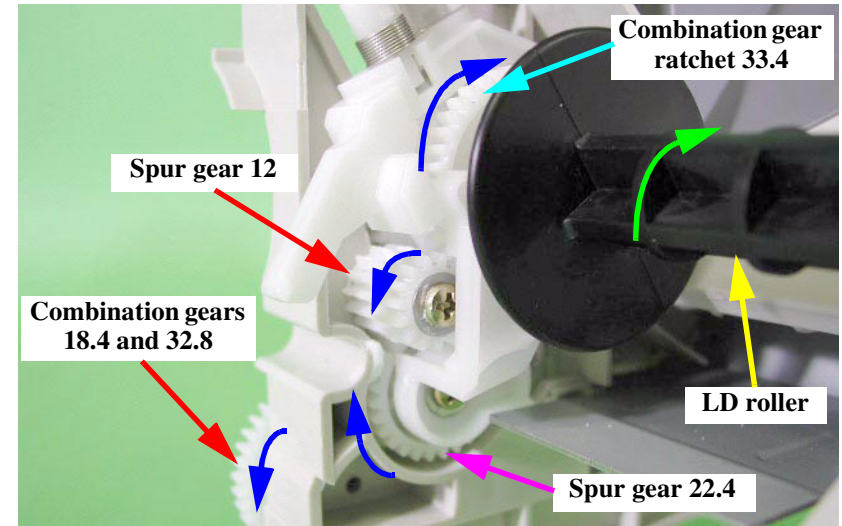

Figure 2-9. Paper feeding (2)

4. When the first sheet of paper has been fed, the second sheet is returned by the paper back lever.



□ Standby condition

1. Print data is not sent to the printer for 3 seconds.
2. The carriage unit moves to the left side of the printer and contacts the change lever, and the driving force from the PF motor causes the planetary unit to rotate counterclockwise so that it contacts the projection on the change lever, and prevents the change lever from returning.

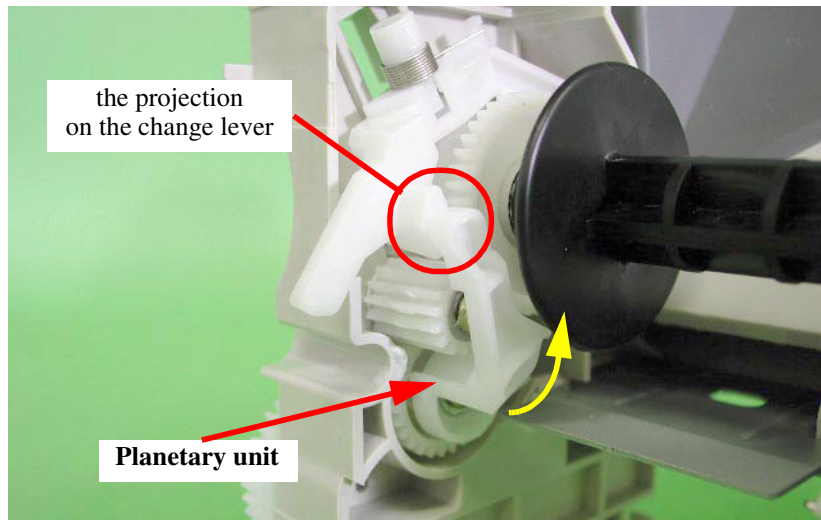

Figure 2-10. Standby condition (1)

3. The driving force from the PF motor is transmitted via combination gears 18.4 and 32.8, spur gear 22.4, the planetary gear set, spur gear 12 and the clutch body in that order, causing the clutch and the LD roller to rotate counterclockwise.

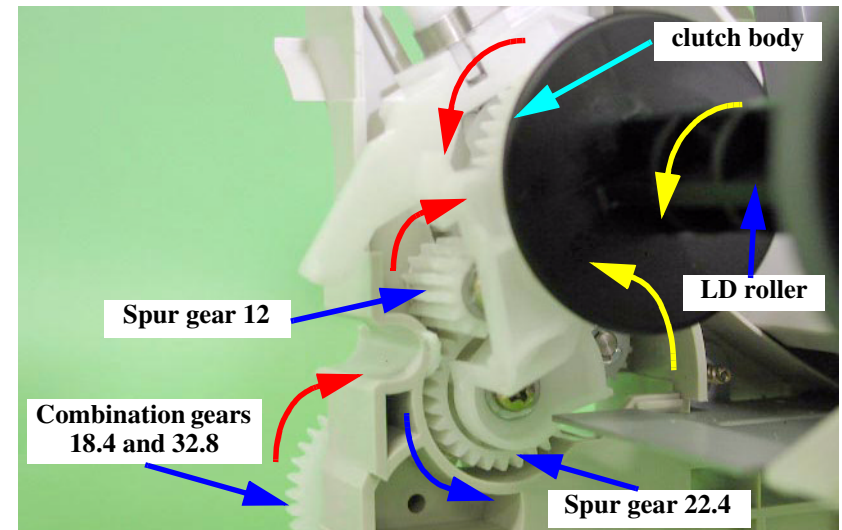

Figure 2-11. Standby condition (2)

4. The hopper is moved back so that 150 sheets of paper can be loaded.

*NOTE: Normally 20 to 30 sheets of paper should be loaded.*



The silence cam and the silence lever on the ASF right frame apply a large amount of torque from A to B in order to move the hopper back to the standby mode position.

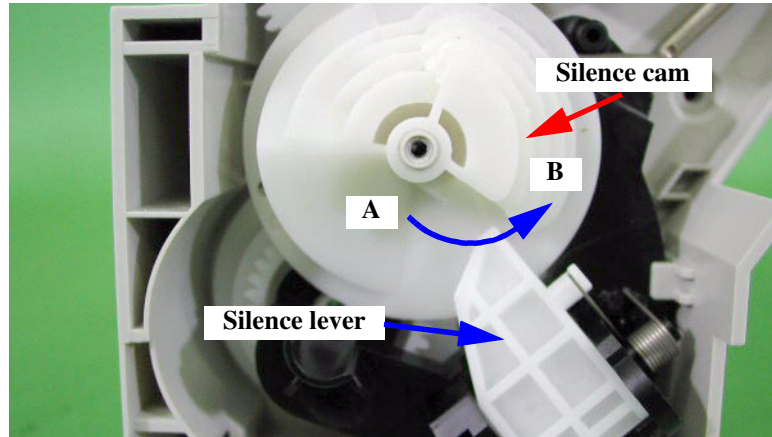

Figure 2-12. Standby condition (3)

During paper feeding, the LD roller is only rotated by combination gear ratchet 34.4, but in standby mode, the planetary gear set drives the drive LD and spur gear 12 drives combination gear ratchet 34.4, and both cause the LD roller to rotate.

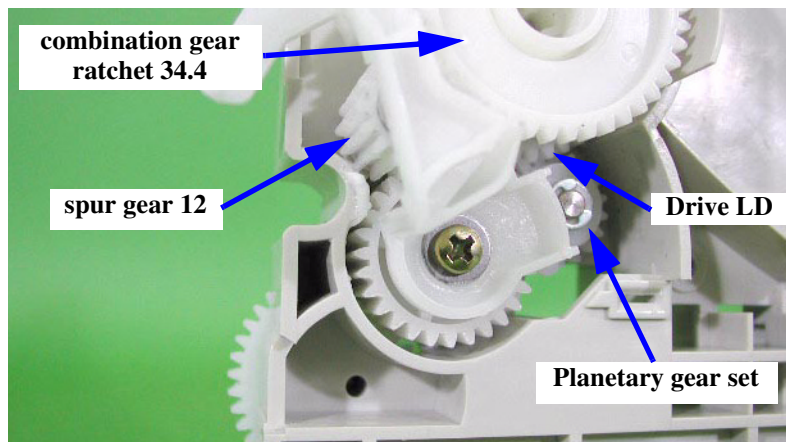

Figure 2-13. Standby condition (4)

### SILENCE CAM MECHANISM

Following is the operation principles mentioned how to operate the silence CAM to drive ASF hopper quietly.

- Step 1 : Initial Status for both Silence CAM and LD Roller
- 1. Usually, silence cam is in the following initial condition. And hopper is in standby condition to allow user to set the paper. (plain paper 150 max.)
- 2. Figure 2-14 shows initial condition for silence cam, and Figure 2-15 shows initial condition for the hopper, LD roller, and paper return lever.

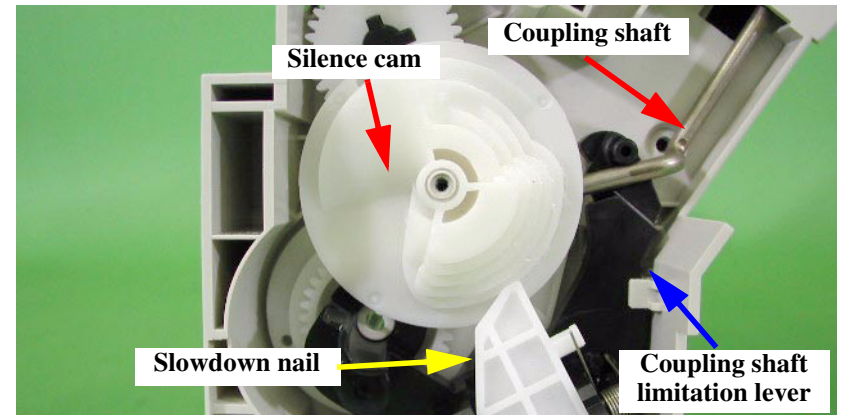

Figure 2-14. Silence Cam mechanism (1)

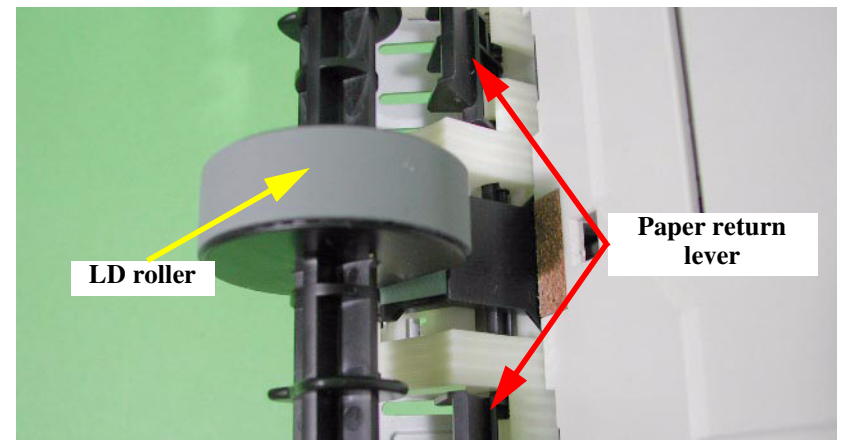

Figure 2-15. Silence Cam mechanism (2)



3. As you can see pictures, hopper is in the stand-by condition depending on "coupling shaft limitation lever" position, and this continues keeping by the "slowdown nail".
4. On the other hands, user can install paper(s) onto the hopper under the initial hopper status, and the "paper return lever" prevents unexpected paper loading into the printer internal.

**NOTE:** To make ASF activate, CR unit moves to left end of the CR shaft to push the ASF trigger lever(ASF change lever), which is coupling in the clutch gear system.

□ Step 2 : Loading Sequence

5. Once the printing data is input or load/eject switch is pressed down, the silence cam will rotate to counterclockwise direction in Figure 2-16 to bring the hopper to the hopper-state. In this sequence, when the top of the "slow down nail" reaches at top of the red row in Figure 2-16, hopper has already been located in hopping state, and a first paper has already been loaded to the printer internal.
6. Figure 2-17 shows the hopper condition when the top of "slow down nail" locates at top of red row in Figure 2-16. At this time, any clatter noise will not be occurred caused by the shape of silence cam.
  - 6-1. Hopper condition:  
Hopper has already been in hopper-state.
  - 6-2. Paper return lever condition:  
Paper return lever is in laid to insert a first paper to the printer internal.
  - 6-3. LD roller has already been on the way of rotating to the forward direction:  
Therefore, some degrees area of a top paper has been loaded to the printer internal.

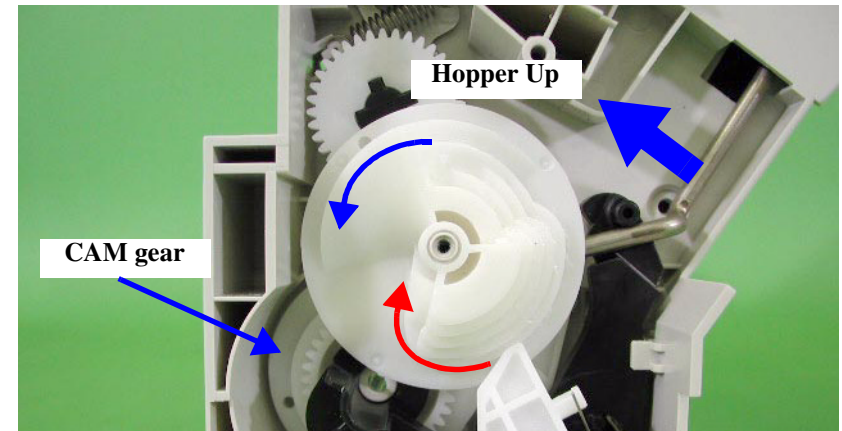

Figure 2-16. Silence Cam mechanism (3)

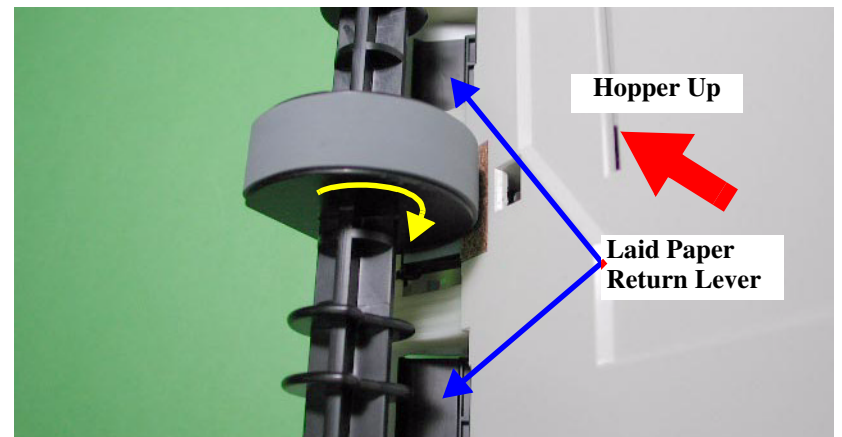

Figure 2-17. Silence Cam mechanism (4)

CHECK  
POINT



Please note that paper return lever is operated by the cam gear located at backside of the silence cam. Refer to Step 5 for details.

□ Step 3 : Paper Return Sequence

7. Once a top paper is loaded to the printer internal, then the paper return sequence will be performed to prevent double feeding after the 2<sup>nd</sup> papers.
8. At point A, when the "slow down nail" passes over a step, the hopper will be returned to the stand-by position from the hopper-state. That because the "upling shaft limitation lever" pulls down the "coupling shaft".



- But the stand-by position Step 8 says does not mean the initial hopper-status which Step 1 shows. And this stand-by position will be decided depending on the total thickness of the current installed papers. (Figure 2-18 case, no paper or small quantity of papers is (are) installed to the hopper.)
- This means, if the total thickness of current installed papers is very thick, slow-down nail will pass over the another step different from "Point A" as shown in Figure 2-18. The Figure 2-19 shows the case when user installs 150 sheets of plain papers on the hopper.

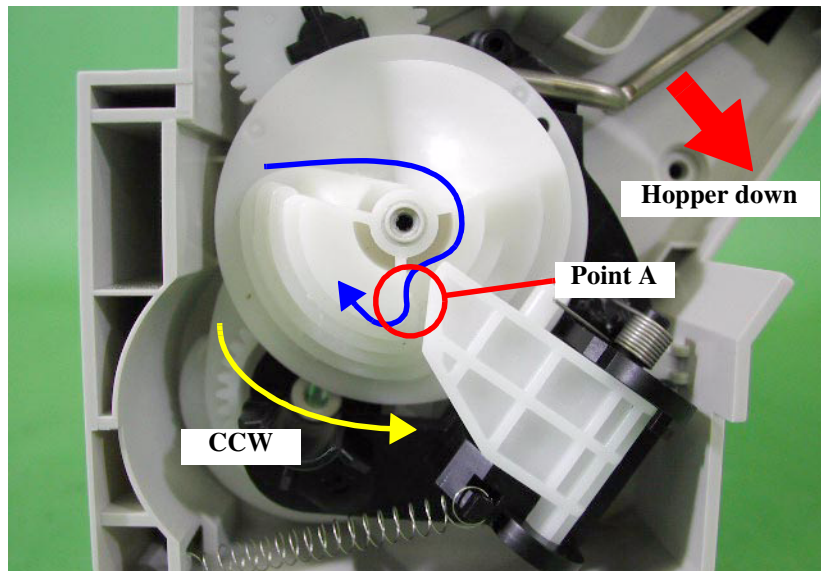

Figure 2-18. Silence Cam mechanism (5)

9. Also, "paper return lever" will suddenly be jumped out as well as the "slow down nail" passes over a step (Point A or Point B). This timing is managed and controlled by the "CAM gear" located on backside of the "Silence CAM". The jumped out "paper return lever" is the same condition to Step 4.
10. After the Step 9 operation completes, once loaded paper will more be loaded and ejected by the friction between PF roller and PF support rollers without ASF operation.

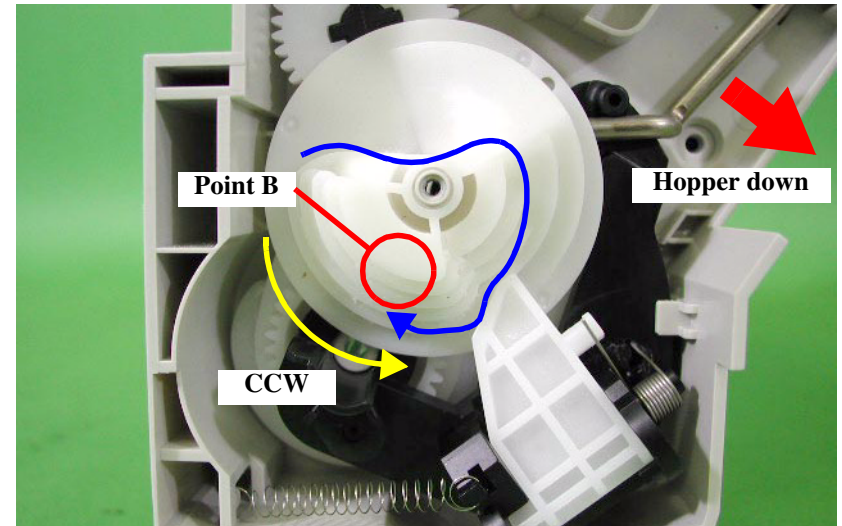

Figure 2-19. Silence Cam mechanism (6)

□ Step 4 : ASF Reset Operation

11. Once a loaded paper is completely printed and ejected, printer will perform the ASF reset operation if the next printing data does not input for a few seconds. Note that the printer will not perform the ASF reset operation if the printing data continues transferring after a 1<sup>st</sup> paper is printed and ejected. Following is its details.

11-1. Stopping the Print Data for a few seconds

If the printer does not receive print data for a few seconds after ejecting a 1<sup>st</sup> paper, "silence cam" will rotate to counter clockwise direction, and will soon change its direction to clockwise direction to make the ASF return to its stand-by condition shown No.1.

After completing this reset operation, user can install more enough papers from the front side of the current installed papers. (maximum 150 sheets of normal plain papers) Because the hopper status is in the same condition to Step 1.

11-2. For the Continue Printing

In case the print data continues transferring from PC as soon as 1<sup>st</sup> paper is ejected, LD roller will rotate to counter clockwise direction again and same operation from Step 5 to Step 10 are performed until the print data is completely printed.

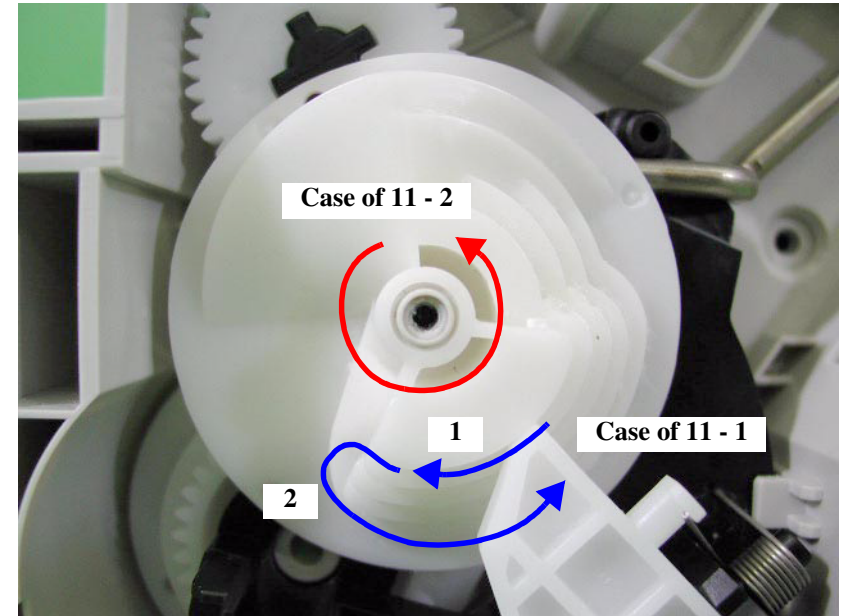

Figure 2-20. Silence Cam mechanism (7)

□ Step 5 : How to Operate Paper Return Lever

Following is the operation principles mentioned how to operate paper return lever.

12. Once you remove the "silence gear", you can see the "cam gear" which has a role for pushing down the "paper return transmission lever".
13. This "cam lever" is always jointed with both the "silence gear" and "super gear 28.8" (for driving LD roller on ASF).
14. When the "silence cam" rotates to counter clockwise, the "cam gear" will rotate to clockwise. And a part of circle arc (cam) on the "cam gear" pushes down the "paper return transmission lever". And paper return lever will be laid to guide a top paper to the printer internal.

**CHECK  
POINT**



There are two alignments on the right side of the ASF to get a correct timing for driving paper load operation and ASF reset operation.

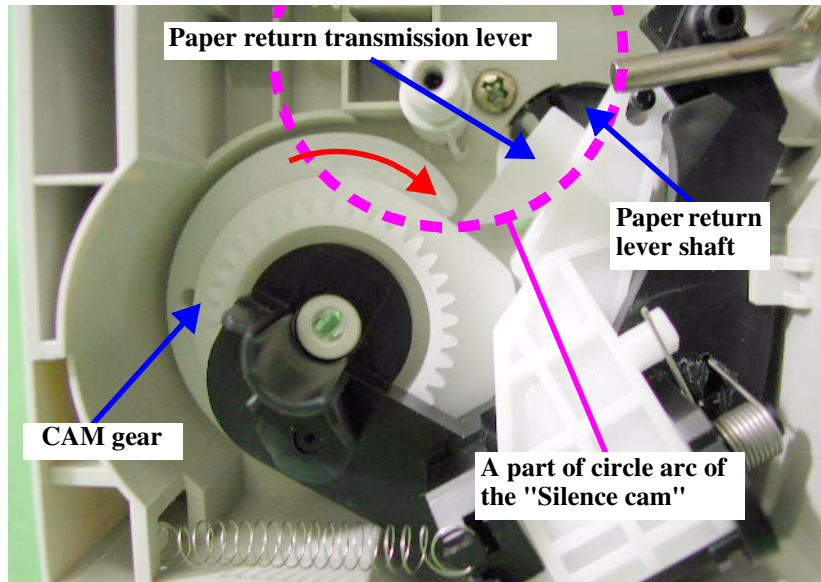

Figure 2-21. Silence Cam mechanism (9)

### 2.1.6 Ink System Mechanism

Ink system mechanism consists of pump unit (include the CR lock lever) and capping mechanism. Ink system mechanism drives the pump unit that presses cap to the printhead and ejects ink from ink cartridge, head cavity and cap to the waste ink pad.

#### 2.1.6.1 Pump Unit & Wiper mechanism

The pump unit is driven by PF motor. PF motor drive is always transmitted to the paper feeding mechanism and pump unit through the following gears. Refer to the Figure 2-23.

The Pump unit and Wiper mechanism drives according to the PF motor rotational direction, as shown in the right table.

**Table 2-3. PF motor rotational direction & Ink System Mechanism**

Directions	Functions
Counterclockwise (*1)	<ul style="list-style-type: none"> <li>• Sets the wiper.</li> <li>• Absorbs ink by the pump unit</li> <li>• Set the CR lock lever</li> </ul>
Clockwise (*1)	<ul style="list-style-type: none"> <li>• Resets the wiper.</li> </ul>

(\*1): The PF Motor rotational direction = seen from the right side of the printer.

Following figure shows the overview of the pump mechanism operation.

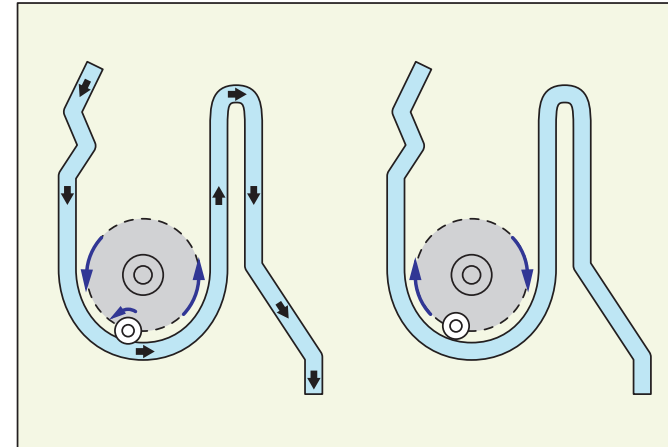

**Figure 2-22. Pump mechanism**

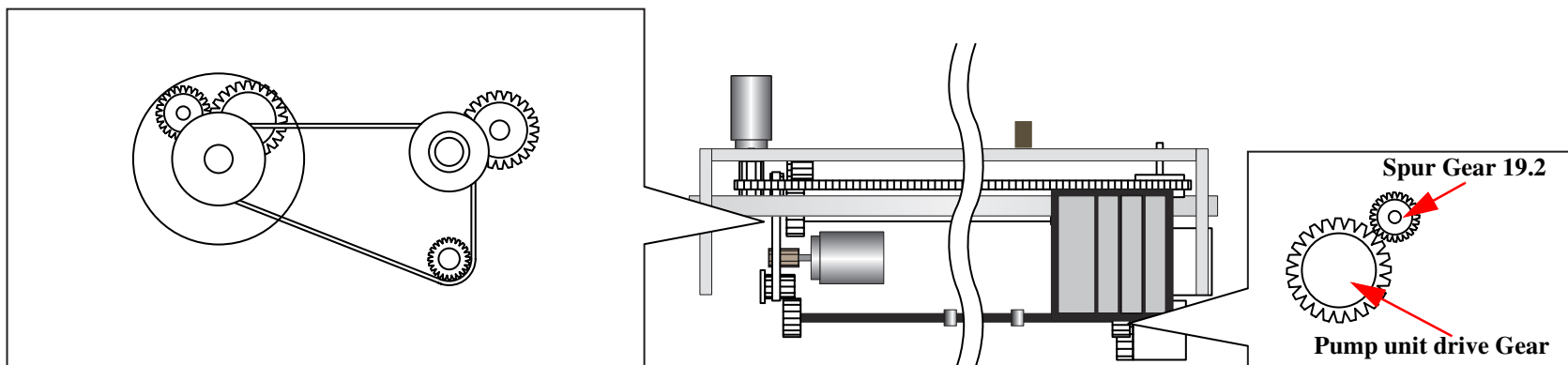

**Figure 2-23. PF motor drive transmission path to the Pump unit**



### 2.1.6.2 Capping Mechanism

The capping mechanism covers the printheads with the cap holder to prevent the nozzle from increasing viscosity when the printer is in stand-by mode or when the printer is off. This product has valveless cap system. Air valve function used for the previous models pumps and ejects ink only inside the cap by absorbing ink with the valve open. By opening the Air valve, the negative pressure is decreased and only the ink inside the cap is ejected. (the ink is not absorbed from Ink cartridge or head cavity.)

But, valveless cap system, this operation is done out side of the capping area.

The CR moves to left side of the Cap assembly and the pump absorbs the ink inside the cap.

1. Due to rationalization, there is no sponge inside the cap.
2. Previously the sponge was provided to prevent frothing during cleaning.
3. Now, since the shape of new cap prevents frothing by its-self, it is not necessary to attach a sponge on the cap.

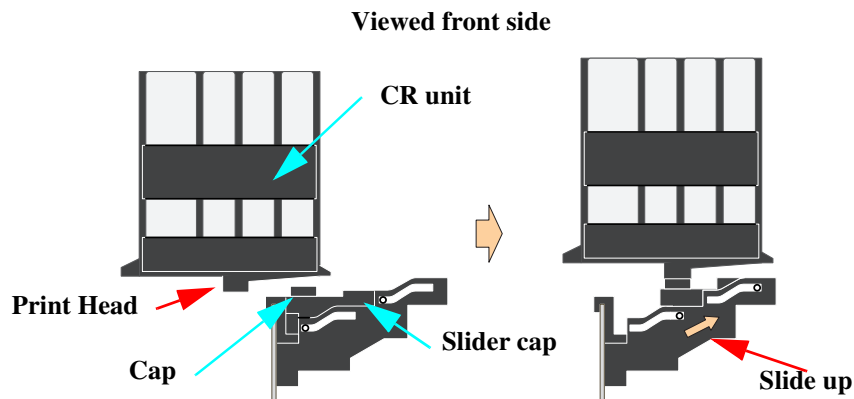

Figure 2-24. Cap Mechanism

## 2.2 Electrical Circuit Operating Principles

The electric circuit of the Stylus COLOR C70/C80 consists of the following boards.

- Main board: C424 MAIN-B Board
- Power supply board: C424 PSB/PSE Board

This section provides operating principles of C424 Main-B Board and C424 PSB/PSE Board. Refer to Figure 2-25 for the major connection of the each boards and their roles.

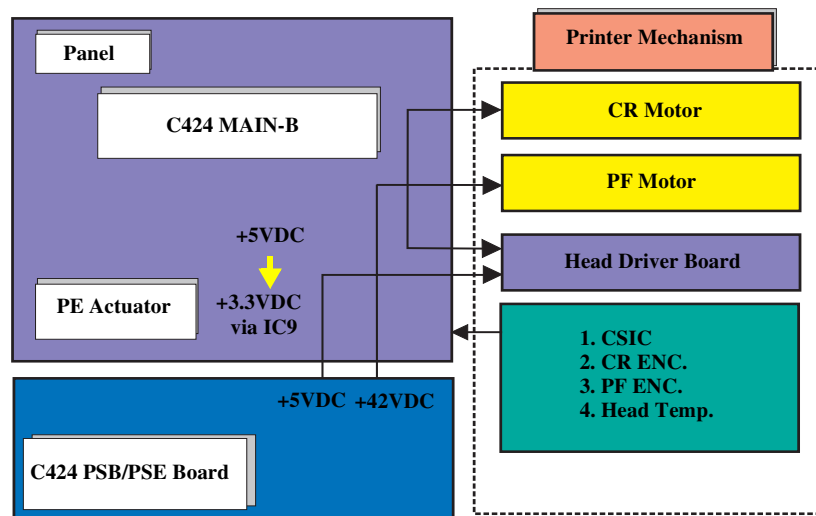

Figure 2-25. Electric Circuit

### 2.2.1 C424 PSB/PSE board

The power supply boards of Stylus COLOR C70/C80 use a RCC (Ringing Chalk Converter) circuit, which generates +42VDC for drive line and +5VDC for logic line to drive the printer. The application of the output voltage is described below.

Table 2-4. Application of the DC Voltages

Voltage	Application
+42VDC	<ul style="list-style-type: none"> <li>• Motors (CR Motor, PF Motor)</li> <li>• Printhead common voltage</li> <li>• Printhead drive voltage</li> </ul>
+5VDC	<ul style="list-style-type: none"> <li>• Source of C424 MAIN-B logic (Actually 3.3VDC is used.)</li> <li>• Source of Sensor</li> </ul>

AC voltage input from AC inlet first goes through filter circuit that removes high frequency components and is then converted to DC voltage via the rectifier circuit and the smoothing circuit. DC voltage is then lead to the switching circuit and FET Q1 preforms the switching operation. By the switching operation of the primary circuit, +42VDC is generated and stabilized at the secondary circuit. This +42VDC generated by the secondary circuit is converted to +5VDC by the chopping regulator IC of the secondary circuit.

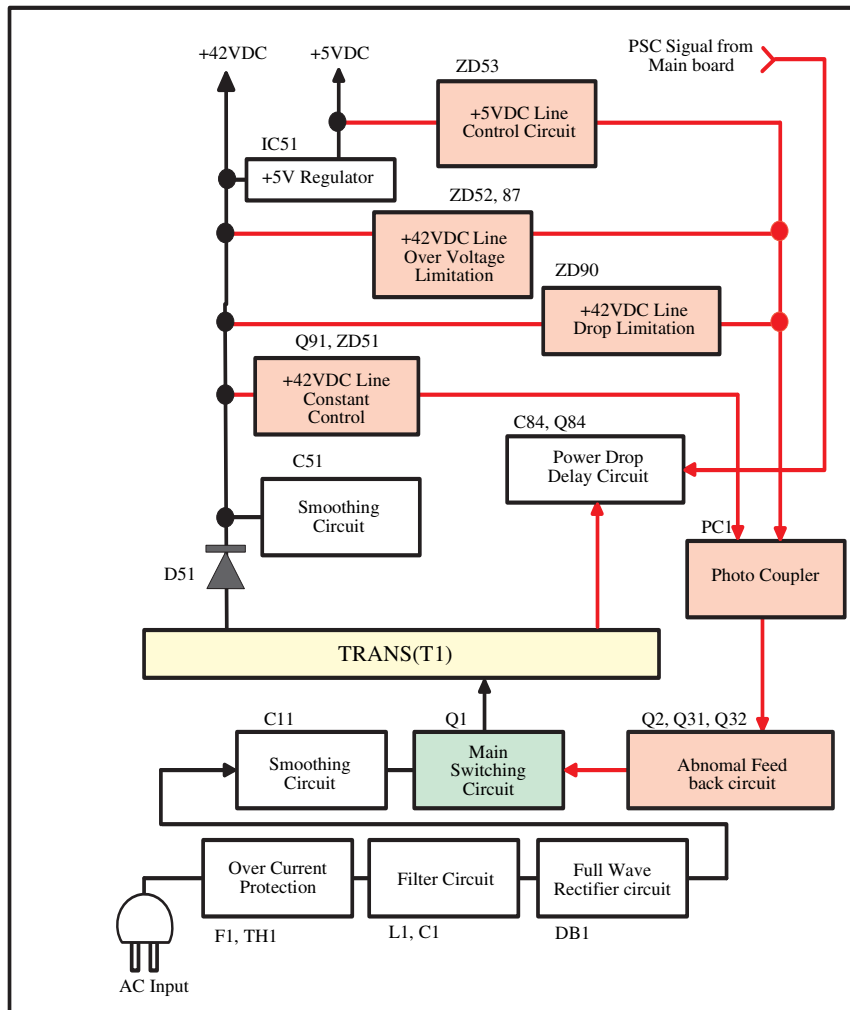

Figure 2-26. C424PSB/PSE Board Block Diagram

The C424 PSB/PSE board has the various control circuits to stop voltage output if a malfunction occurs on the power supply board or the main board while the printer mechanism is on duty. Following explains each control and protection circuit.

1. Regardless of the state of the power switch (On or OFF), the voltage is always applied to the primary side of the power supply board from the moment or at the state that AC-plug is plugged in. At this time, F1 plays a role of preventing AC120 to 220V from coming into the F1. L1 also prevents high harmonic wave noise generated in the RC circuit filter which consists of C1 from going out, and eliminates the noise from outside here.
2. The AC is full-wave rectified by the diode bridge DB1, and converted to  $\sqrt{2} \times$  AC in voltage by the smoothing electrolytic capacitor C11.
3. The pressured up direct current turns Q1 on through the starting resistor R18 and R28 starts the primary side of the circuit.
4. When the primary side is On, the energy (current) led by the electromagnetic induction through the trans (T1) does not flow to the secondary side since the diode (D51) on the secondary side is installed in the opposite direction.
5. When the energy which is charged in the trans is reaching the saturated state, the voltage which makes Q1 on becomes weak gradually. At the point that this voltage drops at the certain voltage, C13 absorbs the current in the opposite direction and Q1 is quickly shut off by the resulting sharp drop.
6. When the primary side is turned off, the energy charged in the T1 is opened according to the diode(D51) direction which is installed on the secondary side. Basically, 42 V DC is output by these circuit operations and the number of T1 spiral coil.
7. +5VDC is generated by pressured down this +42VDC as power supply. IC51 pressures down the +42VDC and generates precise +5VDC by chopping off the output, forming the standard santooth wave form by the outer RCC integration circuit.

The C424PSB/PSE board has the various control circuits to stop voltage output if a malfunction occurs on the power supply board or the main board or while the printer mechanism is on duty. Following explains each control and protection circuit.

- +5V line over voltage protection circuit:  
This protection circuit is in the same line as the +42V over voltage protection circuit is located. The output voltage level of the +5V line is monitored by a Zener diode.(ZD53) This circuit shuts down the +5V line forcefully when the voltage level exceeds +7V.



- +42VDC line drop limitation circuit:  
This protection circuit is in the same line as +42V over voltage protection circuit is located. The output voltage level of the +42V line is monitored by a Zener diode.(ZD90) This circuit shuts down the +42V line forcefully when the voltage level drops to +36V.
- +42VDC line over voltage circuit:  
This circuit is in the same line as +5V line over voltage protection circuit is located. The output level is monitored by two Zener diodes.(ZD52, 87) If the voltage level exceeds +48VDC, this circuit shuts down the +42V line forcefully.
- +5V line control circuit:  
The output current is monitored by the +5VDC generation switching control IC (IC51), which also monitors the output voltage. This information is input to the internal comparator and stabilizes +5V line.

### 2.2.2 C424 MAIN-B Board

The printer mechanism is controlled by C424 MAIN-B.  
See Figure 2-27 for the C424 MAIN-B board block diagram.

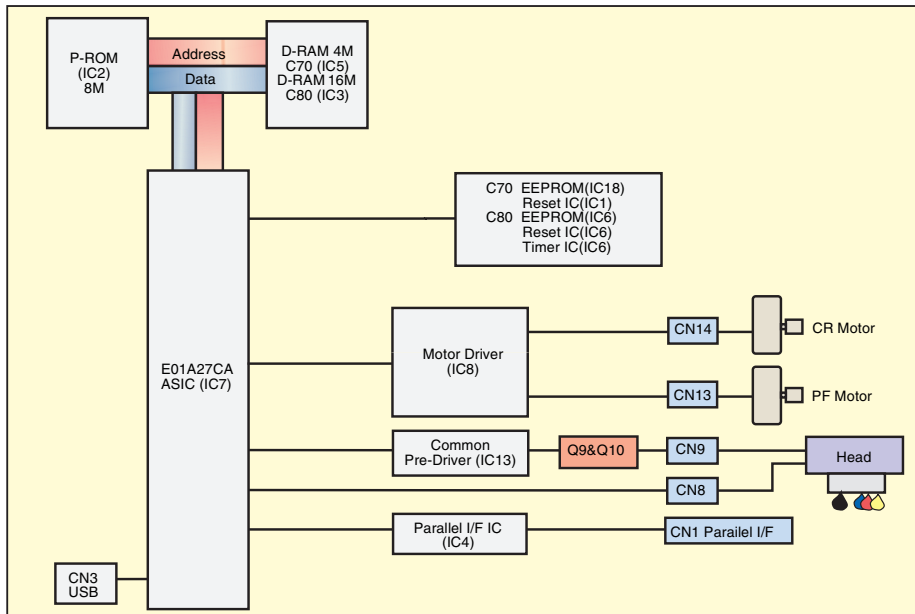

Figure 2-27. Block Diagram for the C424 MAIN-B Board

Following shows you the major characteristic of this main board.

- Use of the 3.3V chips in the logic circuit  
The 3.3 V regulator (IC7) on the C424 MAIN-B produces 3.3 V by pressing down the 5.5 VDC, also generated on this board, to drive several chips. See the table below that separately shows the chips driven by the +5V and +3V.

Table 2-5. 3.3V Drive Chips & 5.5V Drive Chips

+5V	+3.3V
I/F circuit (IC4)	CPU-ASIC 2 in 1 (IC7)
Panel (LED)	PROM (IC2)
Motor Driver (IC13)	DRAM (IC5 or IC3)
Print head Pre-Driver (IC8)	

- Lithium battery are not mounted. (Stylus C70)  
Unlike the previous products, the Lithium battery is not mounted on the Main board. So, this product perform the Power-on cleaning or Timer cleaning based on the time command which is sent from the printer driver.
- On the other hands, Stylus C80 has a timer circuit in IC6. This IC6 is the hybrid IC including EEPROM, Reset circuit and timer circuit. Also, this IC6 has a big capacity capacitor inside IC. Insted of previous lithium battery.
- DRAM  
4Mbit for the Stylus C70 and 16Mbit for the Stylus C80 DRAMS are mounted on the Main board.
- One CPU controls the all function on the main board.
- PROM both  
8Mbit for Stylus C70 and stylus C80 is mounted on the Main borad.  
The timer IC is inside the C80 EEPROM.

### 2.2.2.1 Main elements

Table 2-6, Table 2-7 shows the function of the each main elements on C424 MAIN-B.

**Table 2-6. Main Elements of the C424 MAIN-B (Stylus COLOR C70)**

IC	Location	Function
CPU-ASIC 2 in 1 E01A27CA	IC7	8KB CPU mounted on the MAIN board is driven by clock frequency 24MHz and controls the printer.
PROM	IC2	<ul style="list-style-type: none"> <li>Capacity 8Mbit(Version : THDXX), Bus = 16bit</li> <li>Program and CG for CPU (G: 2 characters)</li> </ul>
DRAM	IC5	Bus = 16bit, 4Mbit DRAM
EEPROM	IC18	2kbit EEPROM <ul style="list-style-type: none"> <li>Default value setting</li> <li>Parameter backup</li> <li>For displaying raster data</li> </ul>
Reset IC	IC1	Reset IC <ul style="list-style-type: none"> <li>For +3.3V; reset when +2.5V is detected</li> <li>For +5V ; reset when +4.2V is detected</li> <li>For +42V ; reset when +36.7V is detected</li> </ul>
Common Pre-Driver	IC13	Head drive control HIC <ul style="list-style-type: none"> <li>Generates head common voltage.</li> </ul>
Motor Driver	IC8	CR/PF motor drive IC
Parallel I/F IC	IC4	IIEEE1284 parallel I/F transceiver IC.

**Table 2-7. Main Elements of the C424 MAIN-B (Stylus COLOR C80)**

IC	Location	Function
CPU-ASIC 2 in 1 E01A27CA	IC7	8KB CPU mounted on the MAIN board is driven by clock frequency 24MHz and controls the printer.
PROM	IC2	<ul style="list-style-type: none"> <li>Capacity 8Mbit(Version : THEXX), Bus = 16bit</li> <li>Program and CG for CPU (CG: 38 characters)</li> </ul>
DRAM	IC3	Bus = 16bit, 16Mbit DRAM
HIC	IC6	[RTC] Electric double layer condenser [Reset] <ul style="list-style-type: none"> <li>For +3.3V; reset when +2.5V is detected</li> <li>For +5V ; reset when +4.2V is detected</li> <li>For Power; reset when +36.0V is detected</li> </ul> [EEPROM] 2kbit EEPROM <ul style="list-style-type: none"> <li>Default value setting</li> <li>Parameter backup</li> </ul>
Common Pre-Driver	IC13	Head drive control HIC <ul style="list-style-type: none"> <li>Generates head common voltage.</li> </ul>
Motor Driver	IC8	CR/PF motor drive IC
Parallel I/F IC	IC4	IIEEE1284 parallel I/F transceiver IC

### 2.2.2.2 Printhead Driver Circuit

The printhead driver circuit consists of the following two components:

- Common driver IC (IC13 : E09A38RA) directly attached to the C424 MAIN-B board.
- Nozzle selector IC on the head board.

The common driver (IC13 : E09A38RA) generates a reference drive waveform according to the output signals from the C424 MAIN-B board. The reference drivewaveform is amplified by the transistors Q9 and Q10 and then transferred to the nozzle selector IC on the head board. Print data is converted to serial data by the CPU (IC7) and then sent to the nozzle selector IC on the head board. Based on the serial data, the nozzle selector IC determines the nozzles to be actuated. The selected nozzles are driven by the drive waveforms produced by the common driver. See Figure 2-28 for the printhead driver circuit block diagram.

Head common driver circuit

The reference head drive waveform is produced in the common driver (IC13 : E09A38RA) based on the following 12 signal lines output from the ASIC (IC7 ) ; A0-A4, CLK1, CLK2, FLOOR, RST, DATA, DCLK, and E.

By the DATA signal output from the CPU (IC7), the original data for the head drive waveform is written in the memory in the IC13. The addresses for the written data are determined by the A0 - A4 signals, and, of among, data used to determine the waveform angles is selected. Then, setting the selected data, producing trapezoid waveform value, and canceling the data are performed by the rising edges of the CLK1 and CLK2 signals.

Head nozzle selector circuit

Printing data is converted into serial data by the CPU (IC7). Then the converted data is allocated to the six rows, the number of the head nozzle rows, to be transferred to the nozzle selector through the seven signal lines (HS01 to HS07). Data transmission from the CPU (IC7) to the nozzle selector synchronizes with the LAT signal and SCK clock signal. Referring to the transferred data, nozzles to be activated are selected, and the PZTs of the selected nozzles are driven by the drive waveform output from the head common driver.

Abnormal temperature detection circuit

Feed back signal from Pin12 and Pin10 in Cn9 are used to head temperature detection. If the temp. inside the head increases 120°C, Printer stops current printing, then make either black or color (YMC) ink cartridge set to ink out.

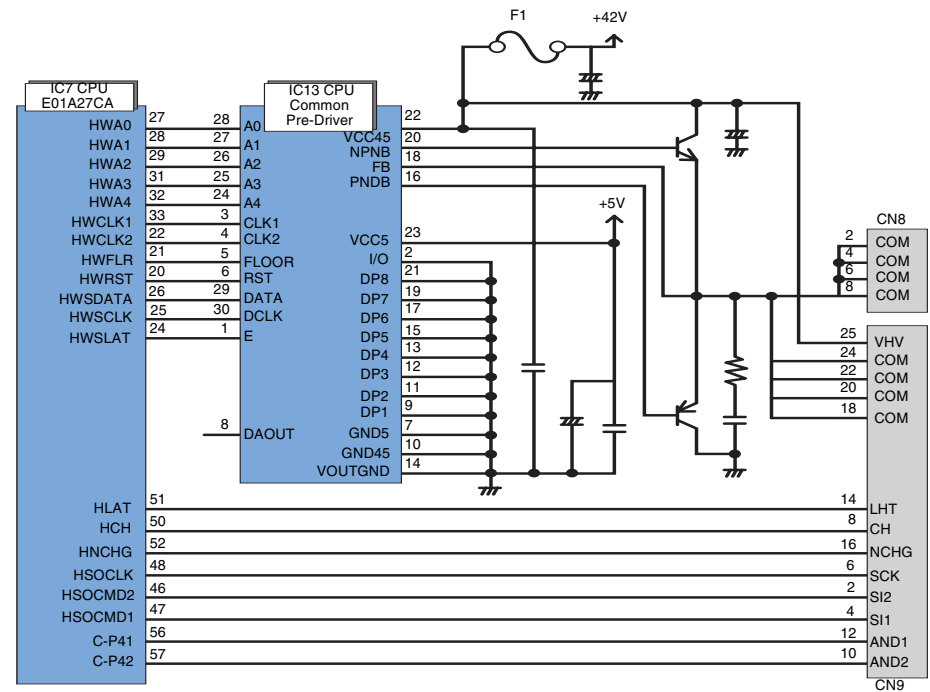

Figure 2-28. Printhead Driver Circuit

### 2.2.2.3 CR / PF Motor (PF/ PUMP/ ASF Motor) Driver Circuit

The motor driver IC (IC8) on the MAIN board drives CR / PF motor. This product uses DC motor and performs constant current PWM drive.

CPU (IC7) converts CR / PF motor REF control signal to A3974 micro step drive form and outputs to motor driver IC (IC8)A3974 from port 52, 63. Based on this signal, IC8 determines the REF mode.

The current value on each phase is determined by CPU (IC7) and outputs from port 138 pin to driver IC (IC8). Motor driver IC generates motor driver waveform based on a input signal and controls the motor. If the printer dose not receive any data from PC for 5 minutes, CPU set the motor drive current to 0 via port 138 pin and the motor drive is turned off to save the power consumption.

The initial bit of the serial data that is output from pin 183 is set to a command that specifies whether the CR motor or the PF motor is to be driven. This product does not carry out any operations in which the CR motor and the PF motor are driven simultaneously, and so control is possible using a single serial data line.

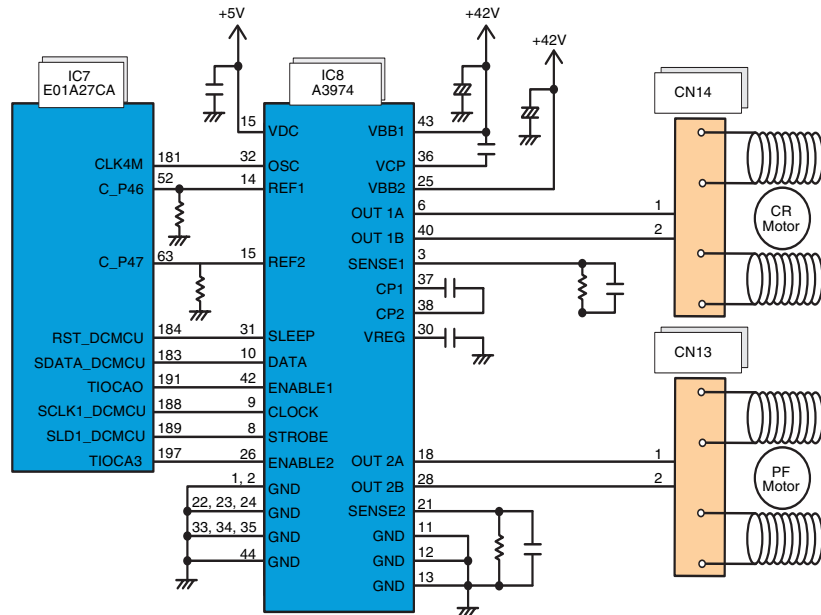

Figure 2-29. CR/PF Motor Driver Circuit Block Diagram

### 2.2.2.4 Reset Circuit

Reset circuits consist of the rest IC (IC6 : Stylus COLOR C70, IC1 : Stylus COLOR C80). Reset circuits are mounted on the MAIN board to monitor the two voltages: +5V for the logic line and +42V for the drive line. When each circuit detects abnormality on the corresponding line, it outputs a reset signal to reset CPU (IC7). This function is necessary to prevent the printer from operating abnormally. This IC monitors both +5V and +45 lines but can reset them independently. The reset circuits outputs reset signal when +5V line becomes 4.2V or lower or +42V line becomes 33.2V or lower.

Unlike the previous products, Stylus C70 has no timer IC and both C70 and C80 have no Lithium battery on the main board.

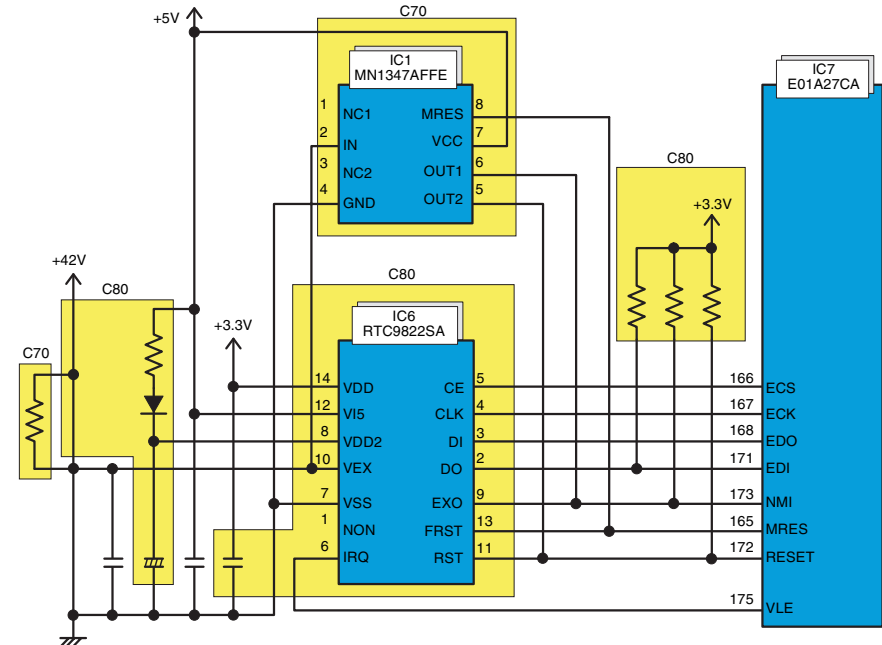

Figure 2-30. Reset Circuit Block Diagram

Main signal lines are explained below;

- OUT1: Interrupt signal
- OUT2: Reset line
- IN: +42V line monitoring line
- VCC: +5V line monitoring line

### 2.2.2.5 EEPROM Control Circuit

Since EEPROM is nonvolatile memory, it keeps written information if the printer power is turned off. When the printer is turned ON, CPU (IC7) reads data from EEPROM (IC6 : Stylus COLOR C70, IC18 : Stylus COLOR C80) via the RAM and when the power is turned OFF it stores data to EEPROM via the RAM.

Information stored in EEPROM is listed below.

- Various ink counter (I/C consumption counter, waste pad counter, etc.)
- Mechanical setting value (Head ID, Bi-D adjustment, USB ID, etc.)

See Table 7-8, “EEPROM Address Map,” on page 187 that provides detailed information on the values stored in EEPROM.

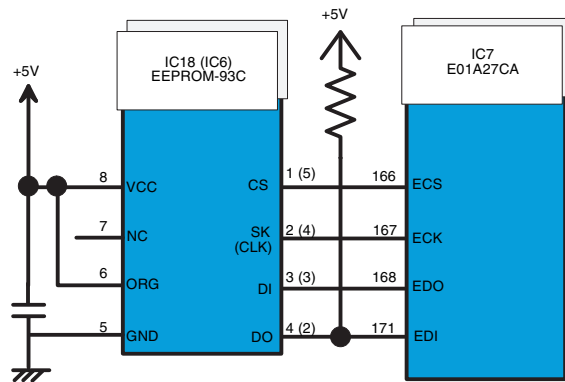

Figure 2-31. EEPROM Circuit Diagram

EEPROM is connected to CPU with 4 lines and each line has the following function.

- CS: Chip selection signal
- SK (CLK): Data synchronism clock pulse
- DI: Data writing line (serial data) at power off.
- DO: Data reading line (serial data) aPEPEt power on.

**NOTE:** Items with brackets are for the C80, and items without brackets are for the C70.

### 2.2.2.6 Sensor Circuit

C424 MAIN-B is equipped with the following one sensor to detect the status of the printer. Unlike the previous product, ASF HP sensor and HP sensor are not equipped and the ASF HP is determined with the clutch mechanism (“Paper Feeding Mechanism”).

#### □ PE Sensor

This sensor uses photo interrupter method and detects the following two status. The photo interrupt component and two detection levers consists of this sensor.

#### ■ Paper Top & End position

When the Paper is in the paper path, this sensor outputs the HIGH signal. When the Paper is not in the paper path, this sensor outputs the LOW signal. This status is always monitored during the printer is in the power on status with this sensor.

#### □ Thermistor (THM)

The thermistor is attached directly on the printhead driver board. It monitors the temperature around the printhead and determines the proper head drive voltage according to the ink viscosity that varies by the temperature. This information is fed back to the CPU analog port. When the temperature rises, the head drive circuit lowers the drive voltage: When the temperature lowers, the head drive circuit rises the drive voltage. This circuit is different from head inside temperature detection circuit. (Please refer to page -56 for details.)

#### □ Linear Scale & CR Encoder

To make the current CR position manage, CR encoder always monitors the bar-code on the linear scale during CR motor drivers. Also this model has no HP sensor and judges the home position when the CR goes out of step at right side.

#### □ Rotary Scale & PF Encoder

To make the paper feed pitch precisely. PF encoder always monitors the bar-code on the rotary scale during PF motor drivers.

The block diagram for the sensor circuit is shown below

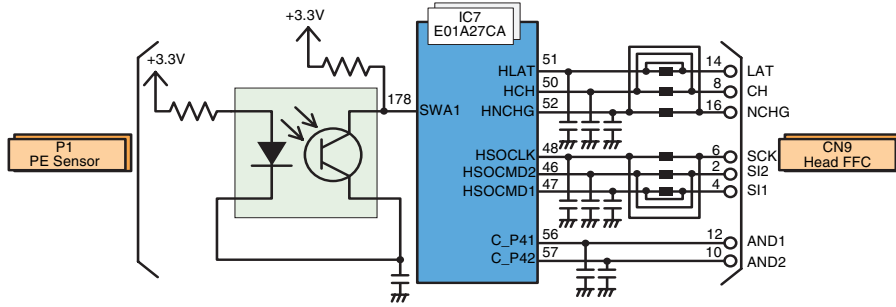

Figure 2-32. PE Sensor Circuit Diagram & Head Around Temperature

CHAPTER

3

# TROUBLESHOOTING



## 3.1 Overview

This chapter describes how to troubleshoot problems. It consists of the sections shown in the flowchart below. When identifying and troubleshooting problems, be sure to proceed to the correct section specified in the flowchart.



- Be careful to avoid electric shocks when checking the electrical circuit boards (C424 MAIN-B, PSE and B circuit boards) while the power is turned on.
- When touching parts such as the FETs or the surface of the heat sink on the transistor with one hand, never touch other metallic parts of the mechanism with your other hand, as the chance of receiving an electric shock at such times is extremely high.



- Disassembly and reassembly of parts is often required when identifying the causes of problems. The parts should be disassembled and re-assembled correctly while referring to "Chapter 4 Disassembly and Assembly" so that the operation and status of each check item can be correctly verified.
- Some individual part and units may require adjustment once they are removed or replaced. If removing or replacing parts which have specific instructions for adjustment included in "Chapter 4 Disassembly and Assembly", be sure to make these adjustments after repairing the problem location.

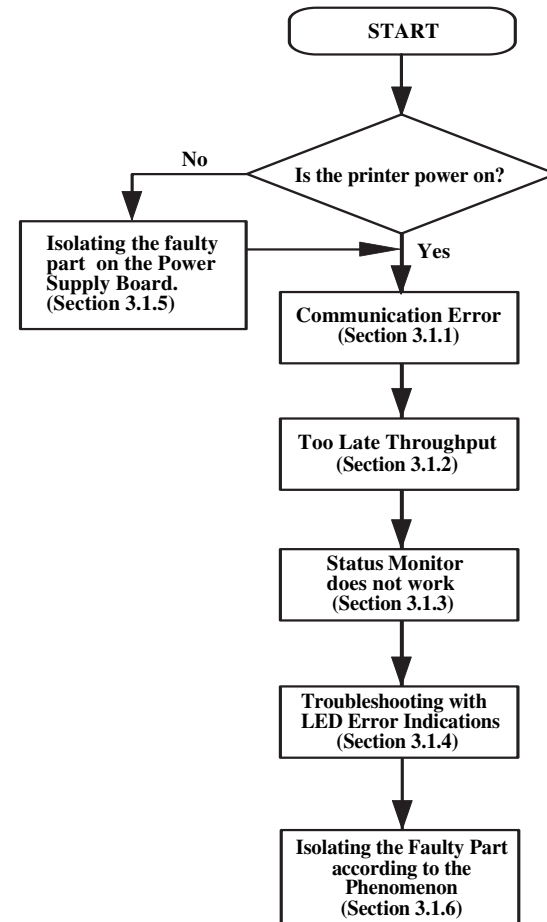

Figure 3-1. Troubleshooting Flowchart

Following sections show detailed information on each step in the flowchart. Be sure to perform troubleshooting without neglecting the correct order specified in each section.

### 3.1.1 Communication Error

This section describes the procedures for solving the problem when no communication at all is received from the computer after the printer power has been turned on, even when initialization has completed normally and the printer is at the standby condition.

**Table 3-1. Communication Error Checking Point**

Step	Check Point	Remedy
1	Is the customer's I/F cable broken?	If communication is possible at all times while working, proceed to the next step. If communication is not possible, change the interface from parallel to USB or vice versa and check if communication is then possible. If there is still no communication, continue to the next step.
2	Use the adjustment program to check the 60H address (interface protocol setting) for the EEPROM.	<p>The relationship between the interface protocol setting status and the setting values is given below.</p> <p>00H: Auto (Default value; communication problems should never occur with this setting.)</p> <p>01H: Fixed to Parallel (Communication problems occur when using USB)</p> <p>02H: Fixed to USB (Communication problems occur when using parallel)</p> <p>To reset, use the Dump function of the adjustment software to rewrite the setting to the default (00H). The relationship between the interface protocol setting status and the setting values is given below. For details, refer to Chapter 5.</p> <p><i>NOTE: The Stylus COLOR C80 has a default setting function, but unlike previous models, interface protocol selection is not possible. Furthermore, the Stylus COLOR C70 does not have its own default setting function. Even if the default value (00H) is changed to 01H or 02H, the EEPROM data may become corrupted, so even if the communication problem is fixed, there is a high possibility that the various adjustment values may be distorted. Because of this, all parameter electrical adjustments should be carried out afresh. Refer to Chapter 5 for details.</i></p>
3	EPSON USB Port (Only for USB User)	If no problems occur when the above two checks are carried out, check with the customer whether the USB port has been installed correctly or not, and if necessary get the customer to reinstall the driver and re-check. (However, this is only for customers who are using USB.)

### 3.1.2 Too Late Throughput

This section describes the procedures for checking printers that have been returned because the printing speed suddenly became much slower after having operated normally up until then. Basically this problem is unlikely to occur in Windows and Macintosh environments because the printer driver is used to transmit data and commands, but it is possible that customers using the printer in a DOS environment may experience this problem.

**Table 3-2. Too Late Throughput**

Step	Check Point	Remedy
1	Use the adjustment program to check the 50H address for the EEPROM.	<p>The relationship between the setting status and the setting values is given below.</p> <p>00H: Bi-D</p> <p>01H: Uni-D</p> <p>02H: Auto</p> <p>To reset, use the Dump function of the adjustment software to rewrite the setting to the default (02H). The relationship between the interface protocol setting status and the setting values is given below.</p> <p>00H: Auto (Default value; communication problems should never occur with this setting.)</p> <p>01H: Fixed to Parallel (Communication problems occur when using USB)</p> <p>02H: Fixed to USB (Communication problems occur when using parallel)</p> <p>To reset, use the Dump function of the adjustment software to rewrite the setting to the default (00H). Refer to Chapter 5 for details.</p> <p><i>NOTE: The Stylus COLOR C80 has a default setting function, and it can be used for setting this item also, so that the setting can be returned to the default without using the adjustment software.</i></p>

**NOTE:** If the problem does not disappear or if it cannot be reproduced when these checks are carried out, refer to "CR Motor Operation Abnormal" in Section 3.1.6.11.

### 3.1.3 Status Monitor does not operate

This section describes the procedures for checking printers when the Status Monitor suddenly can no longer be used to check the printer status, even though the Status Monitor has been operating normally before.

**Table 3-3. Communication Error Checking Point**

Step	Check Point	Remedy
1	Use the adjustment program to check the 64H address (IEEE 1284.4 for parallel) for the EEPROM.	<p>The relationship between the IEEE 1284.4 for Parallel setting status and the setting values is given below.</p> <p>00H: Auto (Status cannot be sent to the computer when the printer has an error)</p> <p>01H: On (Default: Status can be sent to the computer even if the printer has an error)</p> <p>02H: Off (Status cannot be sent to the computer regardless of the printer status)</p> <p>To reset, use the Dump function of the adjustment software to rewrite the setting to the default (01H). Refer to Chapter 5 for details.</p> <p><i>NOTE: The Stylus COLOR C80 has a default setting function, but there is no function available for the customer to change the setting for the 64H address. Furthermore, the Stylus COLOR C70 does not have its own default setting function. Even if the default value (01H) is changed to 00H or 02H, the EEPROM data may become corrupted, so even if the communication problem is fixed, there is a high possibility that the various adjustment values may be distorted. Because of this, all parameter electrical adjustments should be carried out afresh. Refer to Chapter 5 for details.</i></p>

**Table 3-3. Communication Error Checking Point**

Step	Check Point	Remedy
2	Use the adjustment program to check the 65H address (IEEE 1284.4 for USB) for the EEPROM.	<p>The relationship between the IEEE 1284.4 for Parallel setting status and the setting values is given below.</p> <p>00H: Auto (Status cannot be sent to the computer when the printer has an error)</p> <p>01H: On (Default: Status can be sent to the computer even if the printer has an error)</p> <p>02H: Off (Status cannot be sent to the computer regardless of the printer status)</p> <p>To reset, use the Dump function of the adjustment software to rewrite the setting to the default (01H). Refer to Chapter 5 for details.</p> <p><i>NOTE: The Stylus COLOR C80 has a default setting function, but there is no function available for the customer to change the setting for the 65H address. Furthermore, the Stylus COLOR C70 does not have its own default setting function. Even if the default value (01H) is changed to 00H or 02H, the EEPROM data may become corrupted, so even if the communication problem is fixed, there is a high possibility that the various adjustment values may be distorted. Because of this, all parameter electrical adjustments should be carried out afresh. Refer to Chapter 5 for details.</i></p>
3	Has the printer driver been installed correctly?	If the problem cannot be reproduced at the Service Center, get the customer to reinstall the driver and re-check.

### 3.1.4 Troubleshooting with LED Error Indications

This section describes how to troubleshoot the problem when the printer indicates an error at power on and can not print. The Stylus COLOR C70/C80 can detect the following seven errors and indicates them with the LEDs, as shown below.

**Table 3-4. Error Indication**

No.	Error Status	Indication		
		Power	Ink	Load/Eject
1	Paper Out	–	–	On
2	Double Feed	–	–	On
3	Paper Jam	–	Off	Blink
4	Ink out or ink cartridge out	–	On	–
5	(Ink Low)	–	Blink	–
6	Maintenance request	Blink	Blink	Blink
7	Fatal error	Blink	On	Blink

**NOTE:** No.5 ink low indication is not error, and it means just status indication for the user.

**NOTE:** “–” means the LED is not affected by the error condition.

See the following tables which show the error conditions and corresponding possible causes.

This section describes the procedures for solving the problem when an error is displayed. Refer to the table below and carry out each check in the order given. If you are unsure of the detailed procedures, refer to the section indicated in the table and use the instructions given in that section as a reference.

**Table 3-5. Relationship between Error Indication and Presumption Cause**

No.	Error status	Probable cause
1	Paper Out (Refer to Section 3.1.4.1)	1. The paper feed roller's ability to pick up the paper has dropped.
2	Double Feed (Refer to Section 3.1.4.1)	2. One or both of the two hooks that secure the hopper to the ASF are disengaged. 3. There is a piece of paper lodged in between a paper load sub roller and the PF roller.
3	Paper Jam (Refer to Section 3.1.4.1)	4. The bushing at the left of the PF roller is dislodged from the mechanism and is not rotating smoothly. 5. The powder coating on the PF roller shaft is extremely dirty or has sections that are missing powder. 6. The EJ roller holder is not secured to the paper eject roller shaft and is loose. 7. The bushings 5 are not securing both ends of the paper eject roller shaft and the whole shaft is loose, or the shaft rotation is not stable. 8. Some of the toothed rollers (star wheels) on the paper eject frame have fallen down or are not secured properly. 9. The PE lever for the PE sensor is not installed correctly, or is loose, or the end of the lever is broken. 10. The PE lever for the PE sensor is installed correctly, but the lever does not operate correctly. 11. The spring at the bottom of the separation pad on the ASF has come off and fallen down, and the paper cannot travel correctly. 12. The EJ grounding wire or the PF grounding wire has come off and is obstructing the paper path. 13. The surface of the linear scale that passes through the underside of the carriage is contaminated with paper dust. 14. The space between the emitter and receiver of the photo sensor on the underside of the carriage is blocked by paper dust, or the linear scale is not in the middle position and when the carriage is moved manually, it touches against the emitter or the receiver. 15. The FFC is disconnected from connector CN1 on the circuit board underneath the carriage, or when you try to push it in it feels as if it can go in further.

Table 3-5. Relationship between Error Indication and Presumption Cause

No.	Error status	Probable cause
3 (Cont.)	Paper Jam (Refer to Section 3.1.4.1)	<p>16.The paper back lever has come off and fallen down, and the paper back function does not work.</p> <p>17.The projection on the ASF rib for inserting the paper back lever is broken, and the paper back lever falls off as soon as it is reinstalled.</p> <p>18.The spring that applies tension to the paper return lever has come off and fallen down.</p> <p>19.One or more of the four points that secure and control the hopper drive shaft have become loose, and the hopper cannot operate according to control instructions.</p> <p>20.Malfunction of the PE sensor.</p> <p>21.Paper that is outside specifications or that is longer than the currently-set paper size is being used.</p> <p><i>NOTE:If paper out, double feed or a paper jam is detected, they may all occur for the any of the above reasons, and so the reasons are listed all together without being separately classified.</i></p>
4	Ink end or ink cartridge out (Refer to Section 3.1.4.2)	<p>1. The cartridge is not correctly inserted, and the cartridge cannot be correctly detected.</p> <p>2. The CSIC chip is not connected correctly, or it is completely disconnected and communication with the main unit is not possible.</p> <p>3. The contact electrodes of the carriage CSIC chip are broken or bent.</p> <p>4. The FFC is disconnected from connector CN1 on the circuit board underneath the carriage, or when you try to push it in it feels as if it can go in further.</p> <p>5. Connector CN8 on the main board is disconnected or nearly disconnected.</p> <p>6. A heat hot error has occurred.</p> <p>7. The actual amount of ink remaining and the remaining ink data recorded in the CSIC EEPROM are mismatched as a result of a refilling operation.</p> <p>8. The data in the CSIC EEPROM is corrupted.</p>
5	Ink Low Indication (Refer to Section 3.1.4.3)	No error status is indicated, but an ink low indication continually appears while the carriage is returning to the home position even though the I/C has been replaced with a new I/C. (Example of actual question from the marketplace)

Table 3-5. Relationship between Error Indication and Presumption Cause

No.	Error status	Probable cause
6	Maintenance Error (Refer to Section 3.1.4.4)	Ink overflow request always appears.
7	Fatal error (Refer to Section 3.1.4.5)	<p>1. The linear scale is not moving in between the photo sensor (photo coupler) parts on the underside of the carriage.</p> <p>2. The FFC for transmitting the carriage photo sensor detection signal to the main board is disconnected or almost disconnected from the relay board on the underside of the carriage.</p> <p>3. The rotary scale is not moving in between the PF encoder (photo coupler) parts.</p> <p>4. CN12 (white: 4-pin) on the main board is disconnected.</p> <p>5. CN8 on the main board is disconnected or almost disconnected.</p> <p>6. The coil inside the CR motor has seized.</p> <p>7. The coil inside the PF motor has seized.</p> <p>8. Malfunction of motor driver IC</p> <p>9. Malfunction of PF motor photo sensor</p> <p>10.Malfunction of CR motor photo sensor</p>

### 3.1.4.1 Remedy when a paper out, double feed or paper jam error occurs

This section provides check points and corresponding actions which are necessary when the Paper Out Error problem has occurred because of either of the following reasons:

- Paper is set in the ASF hopper but not fed.
- Paper is fed but not detected by the printer.

Indicates the checks and remedies to be carried out if the paper feeds normally and the printer can recognize this, but the paper jams during printing or when it is being ejected.

The reason why possible causes of paper out and double feed errors are listed together is because double feeding during duplex printing can cause problems with page numbering and render the whole printing job useless, so that if it is judged that the paper is longer than the normal length, the current page is fully ejected, and then a paper out error is indicated straight away to prompt the customer to reset the paper. Furthermore, it is also assumed that such double-feed errors will result in the paper running out before the last page or the last few pages are printed, and so double feed and paper out errors are handled in the same way. This is considered to be a refinement of conventional paper jam detection.

Be sure to follow the steps in the order described in the tables.

**NOTE:** If the finding for the question is Yes, take the action described in the right column. If “No”, proceed to the next step.

Table 3-6. Communication Error Checking Point



Step	Check Point	Remedy
1	Is no paper loaded?	<p>Set a cleaning sheet in the ASF up side down. Then holding the top edge, press the Load/Eject button, and the micro pearl on the paper load roller (a semicircular roller) surface is removed. To remove severe smear, staple a cloth moistened with alcohol to a post card and clean the roller in the same manner.</p> <p><i>NOTE: Customers must never use cleaning sheets with this printer. The procedures described here is for use only by qualified technicians when carrying out repairs.</i></p> <div style="display: flex; justify-content: space-around; align-items: center;"> <div style="border: 1px solid black; padding: 5px; text-align: center;">  <p>Non-adhesive Area</p> <p>CL Sheet</p> <p>Adhesive Area This side down</p>  </div> <div style="border: 1px solid black; padding: 5px; text-align: center;"> <p>(Use a post card for the base sheet.)</p>  <p>Staplers</p> <p>Cloth moistened with alcohol</p> </div> </div>
2	Has the hopper come away from the ASF?	<p>If the two hooks that secure the hopper to the ASF are not correctly attached, insert the hooks correctly into the holes in the ASF.</p> 

Table 3-6. Communication Error Checking Point

Step	Check Point	Remedy
3	Is there any paper lodged in between a paper load sub roller and the PF roller?	Clean away any paper or other foreign particles that may be caught in the rollers.  <b>Slip of paper or foreign substance.</b>
4	Is the PF roller bushing dislodged from the mechanism and not rotating smoothly?	Return the bushing to the correct position.  <b>Correct Location</b> <b>Busing for PF Roller Shaft</b>
5	Is the PF roller bushing dislodged from the mechanism and not rotating smoothly?	Use a cloth moistened with alcohol to clean away severe contamination. If the PF roller is damaged, it should be replaced.  <b>Many Paper Powders or a Big Scratch Marks on the PF Roller Shaft</b>

Table 3-6. Communication Error Checking Point

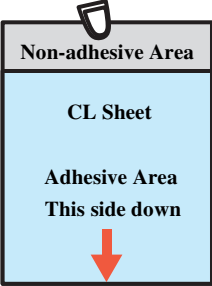
Step	Check Point	Remedy
6	Is the EJ roller holder not secured to the paper eject roller shaft and is it loose?	Place the EJ roller holder in the correct position.  <b>Lifted EJ Roller Holder</b>
7	Has the bushing 5 that secures the paper eject roller shaft come away from the hook and is not rotating smoothly?	Place the bushing 5 in the correct position.  <b>Bush 5</b> <b>Correct Hook Point</b>
8	Have any of the star wheels come away from the paper eject frame?	Place the star wheels in the correct position.  <b>Incorrect Status</b> <b>Correct Status</b>

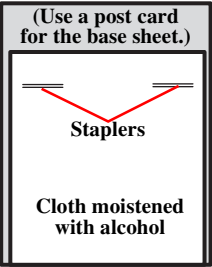
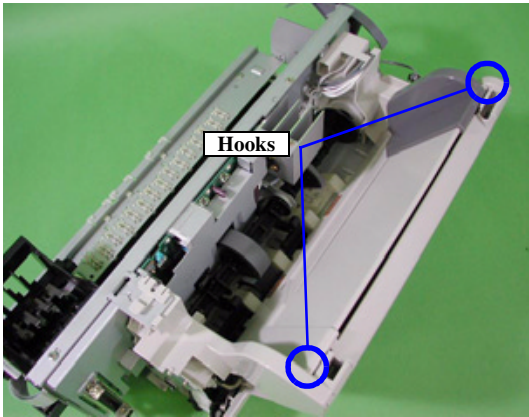

Table 3-6. Communication Error Checking Point

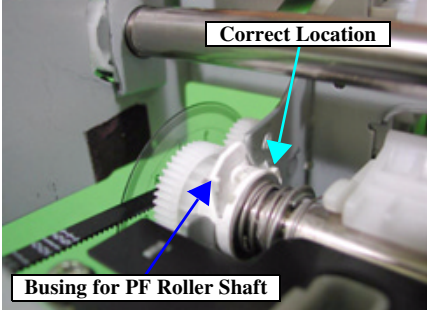
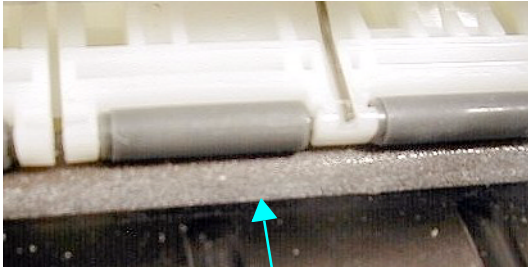
Step	Check Point	Remedy
9 10 11	Does the PE lever not work correctly?	<p>Move the PE lever at the rear of the printer manually and check if it returns normally as soon as it is released. If it does not return, the cause might be one of the following three reasons.</p> <ol style="list-style-type: none"> <li>1. The PE lever has come away from the base.</li> <li>2. Scraps of paper have collected around the PE lever so that the PE lever cannot operate correctly.</li> <li>3. The PE lever itself is broken and cannot detect the paper feed and paper eject timing correctly.</li> </ol>  <p>If the tension spring for the PE lever has come off, reinstall it while referring to the illustration below.</p> 

Table 3-6. Communication Error Checking Point

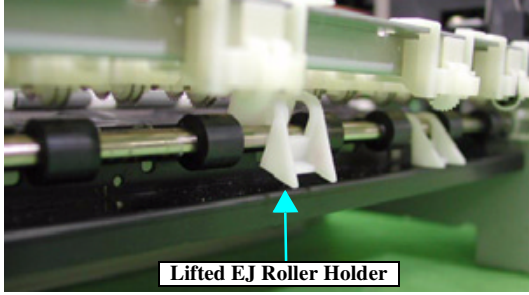
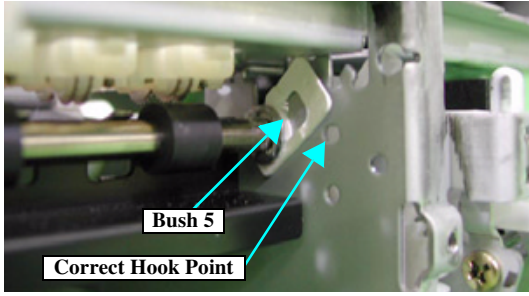
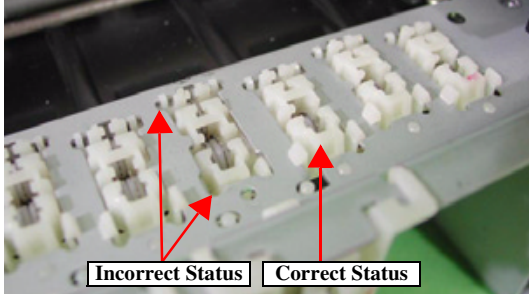
Step	Check Point	Remedy
12	Has one of the grounding wires become disconnected and is blocking the paper path?	<p>Check both the PF grounding wire and the EJ grounding wire. If a wire is not in the correct position, pull it out and re-install it in the correct position.</p> <p>[PF Grounding Wire]</p>  <p>[EJ Grounding Wire]</p> 

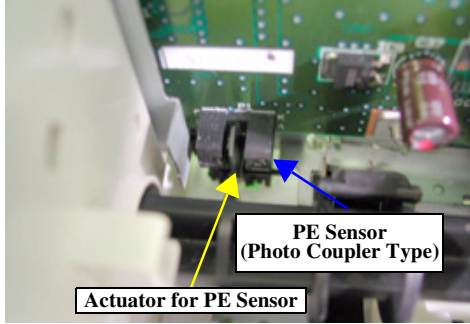
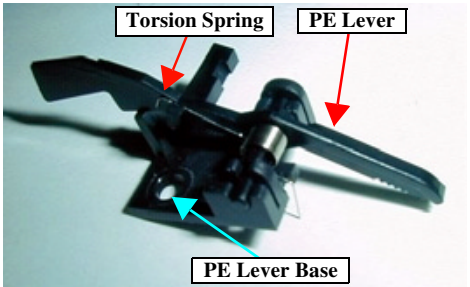

Table 3-6. Communication Error Checking Point

Step	Check Point	Remedy
13	Is the surface of the linear scale that passes through the underside of the carriage contaminated with paper dust?	<p>If the surface is dirty, remove the linear scale and clean it with a cloth moistened with alcohol.</p> 
14	Is the inside of the CR encoder on the underside of the carriage blocked with paper or dust? Also, is the position of the linear scale correct?	<p>Look through the cut-away part of the mechanism at the home position side of the carriage and check if the encoder (photo coupler) is blocked with paper or dust. If it is blocked with paper or dust, use a cotton swab or similar to clean away the blockage.</p> <p>In the same way as above, check the condition of the linear scale. Ideally the linear scale should be in the middle of the encoder, but it is okay if the carriage does not touch either end when it is moved manually.</p> 

Table 3-6. Communication Error Checking Point

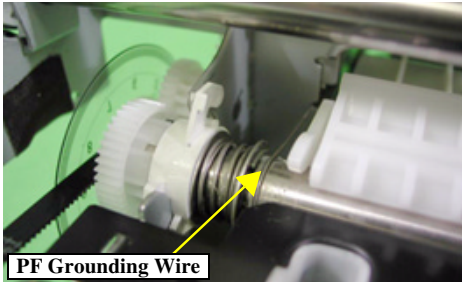
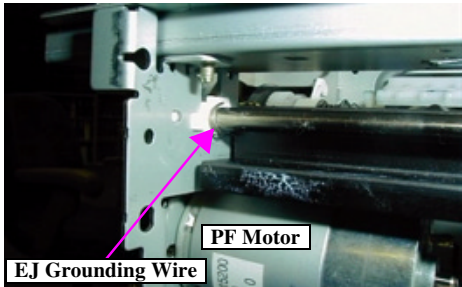
Step	Check Point	Remedy
15	Is the FFC disconnected from connector CN1 on the circuit board underneath the carriage, or does it look to be okay but when you try to push it in does it feel as if it is slightly loose?	 <p>CN1 is the connector that handles the input and output of signals between the main board and the mechanism. It inputs the various encoder signals to the main board from the mechanism, and outputs head drive signals from the main board.</p>
16	During paper back (ASF reverse drive) operation, does the paper back lever not operate because it falls off, and does a double feed error always appear, or do paper jams always occur during paper feeding? Please Note that "Paper back lever" is located on backside of "Silent CAM".	<p>The paper back lever is inserted onto the ribbed shaft on the ASF right frame as shown in the photograph. Because of this, if the rib becomes broken, the paper back lever may fall off during operation. If the rib on the paper back lever shaft becomes broken, replace the ASF right frame or replace the ASF unit.</p> 
17		<p>If the end of the paper back lever itself is broken, or if the other rib on the underside of the paper back lever (not shown in the photograph) is broken and the two paper return levers (back flaps) inside the ASF unit cannot be operated, replace the paper back lever.</p>

Table 3-6. Communication Error Checking Point

Step	Check Point	Remedy
18	The spring that applies tension to the paper return lever inside the ASF has come off from its normal position, and so no tension is being applied.	<p>The photograph below shows the normal setting position for the paper return lever tension spring.</p> 
19	The shaft that drives the ASF hopper is secured in a total of four places. Has it come loose in one of these places, so that the incorrect timing or incorrect operation is occurring?	
20	Malfunction of PE sensor	<p>Because the only sensor check point is pin 178 of the ASIC (IC7) port and the tester must be applied directly to the pin, testing is dangerous and difficult. This printer has the PE sensor directly installed, so it is recommended that checking the PE sensor should be carried out by replacing the circuit board and checking the operation. At this time, the head ID only should first be input to the EEPROM on the main board so that a head hot error does not occur. No other adjustments are required when carrying out checking.</p>

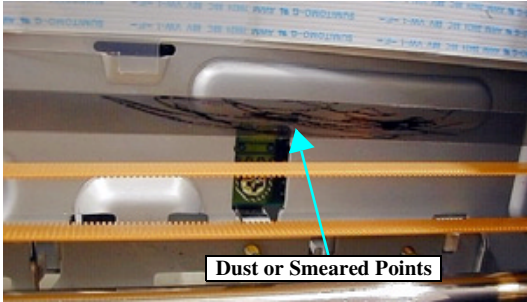
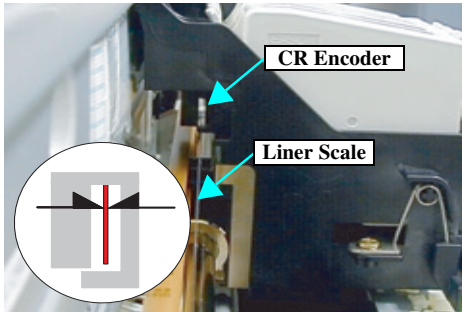
Table 3-6. Communication Error Checking Point

Step	Check Point	Remedy
21	If the customer uses paper which is longer than the set paper length, no paper out indication will appear even though the printer sends the regular number of pulses, so is this causing a paper jam error to be recognized?	<p>If the problem cannot be identified even after carrying out steps 1 to 19 above, the customer may have installed the printer driver incorrectly, so check the method of use and the printer driver settings directly with the customer.</p>

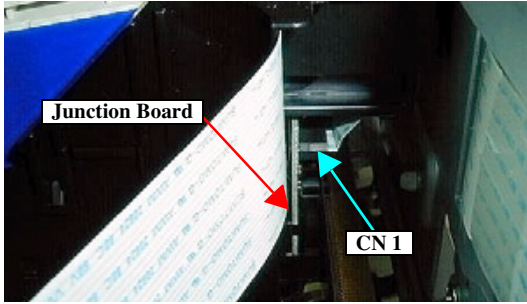
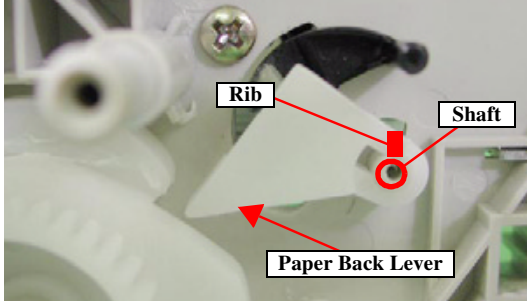
### 3.1.4.2 Remedies for No I/C and Ink Out Errors

This section includes the check points and corresponding actions which are necessary when the black ink (or color ink) LED comes on or blinks at power on despite the ink cartridge has been replaced with a new one.

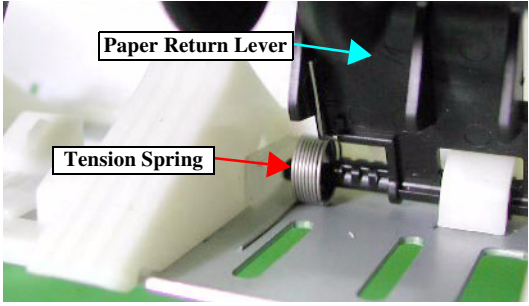
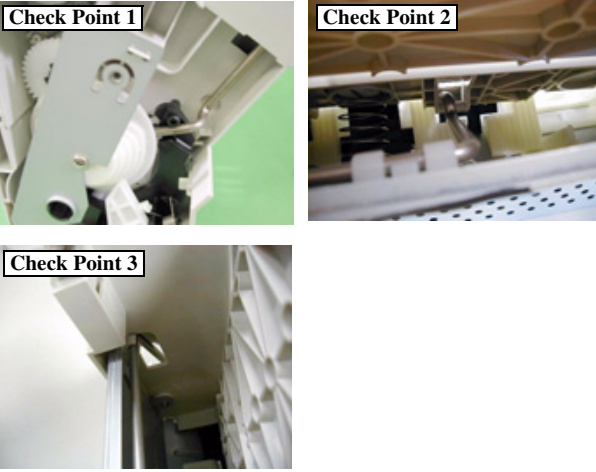
Be sure to follow the steps in the order described in the tables.

**NOTE:** If the finding for the question is Yes, take the action described in the following. If “No”, proceed to the next step.

**Table 3-7. This section describes the procedures for solving the problem when an ink out (cartridge out) error is displayed even though a brand-new ink cartridge has been installed.**

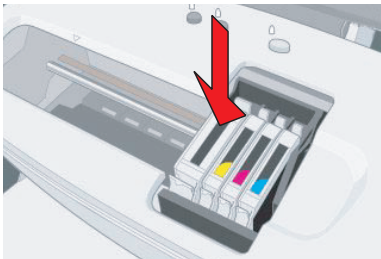
Step	Check Point	Remedy
1	Has the cartridge not been correctly inserted, so that the cartridge cannot be correctly detected?	<p>Carry out the ink cartridge replacement operation and check if an ink out or ink cartridge out error occurs no matter which ink cartridge is used. Because the carriage moves to the position of the marking on the carriage, it is possible that an ink cartridge is not being detected. If a particular cartridge is not being detected, lift this cartridge up to the replacement position and then push it in firmly.</p>  <p>If the ink out indication disappears after the above operation has been carried out and the carriage has returned to the home position, the cause of the problem can be assumed to be the reason given at left. If this does not solve the problem, proceed to the next step.</p> <p><b>NOTE:</b> This printer has sus-plates installed to the carriage in order to assist with securing and removal of the ink cartridges. The heights of the sus-plates that apply tension to each color ink cartridge can be changed in order to alert the customer to the fact that the cartridges have not been inserted correctly because they are uneven.</p>

**Table 3-7. This section describes the procedures for solving the problem when an ink out (cartridge out) error is displayed even though a brand-new ink cartridge has been installed.**

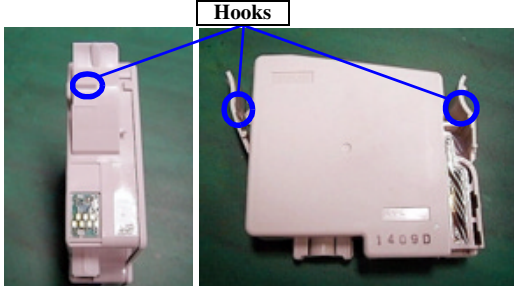
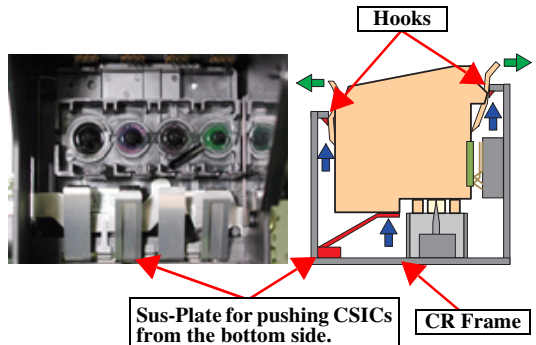
Step	Check Point	Remedy
2	Is one or both of the two hooks on the ink cartridge broken so that tension is not being applied?	 <p><b>NOTE:</b> Even if one hook is broken, the electrodes on the chip and the carriage will not contact correctly.</p>
3	When the carriage CSIC was mounted, did the sus-plate for applying tension to the CSIC fall down?	<p>Because initial models did not have a cartridge clamp, the sus-plates had a stepped section so that the customer could check if the cartridges had been securely installed or not. If the cartridge was not securely installed, the tops of the various color cartridges would not be in a straight vertical line, and this would notify the customer that a cartridge had to be re-inserted. Correct installation of the ink cartridges is only achieved when the two hooks in No. 1 above and the tensions of the sus-plates mentioned here are normal.</p> 

**Table 3-7. This section describes the procedures for solving the problem when an ink out (cartridge out) error is displayed even though a brand-new ink cartridge has been installed.**

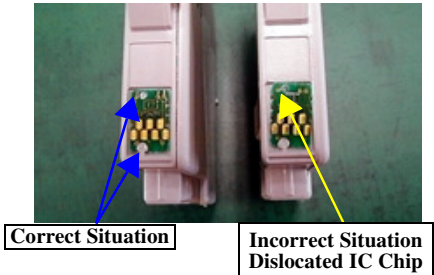
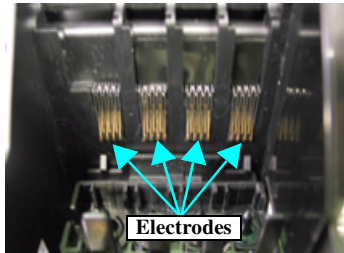
Step	Check Point	Remedy
4	Has the IC chip (EEPROM) that is mounted to the CSIC become detached or is it becoming detached?	<p>If the CSIC chip is even slightly dislocated, the electrodes will not come into correct contact with the carriage electrodes and the printer will not recognize the cartridge.</p>  <p><b>Correct Situation</b>      <b>Incorrect Situation Dislocated IC Chip</b></p> <p><i>NOTE: If an ink cartridge with no CSIC chip is installed, not only will the ink cartridge fail to be recognized, but it will also damage the carriage electrodes.</i></p>
5	Are the contact electrodes of the carriage CSIC chip broken or bent?	 <p><b>Electrodes</b></p>

**Table 3-7. This section describes the procedures for solving the problem when an ink out (cartridge out) error is displayed even though a brand-new ink cartridge has been installed.**

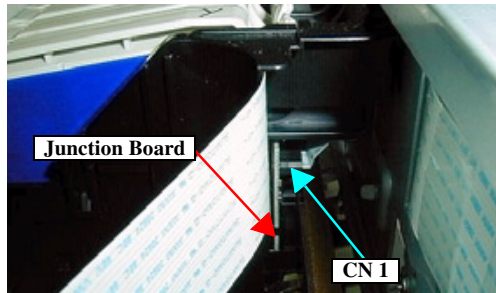
Step	Check Point	Remedy
6	Is the FFC disconnected from connector CN1 on the circuit board underneath the carriage, or does it look to be okay but when you try to push it in does it feel as if it is slightly loose?	 <p><b>Junction Board</b>      <b>CN1</b></p> <p>CN1 is the connector that handles the input and output of signals between the main board and the mechanism. It inputs the various encoder signals to the main board from the mechanism, and outputs head drive signals from the main board.</p>

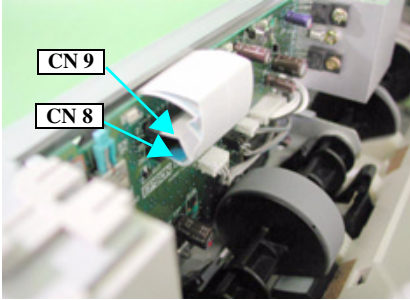

**Table 3-7. This section describes the procedures for solving the problem when an ink out (cartridge out) error is displayed even though a brand-new ink cartridge has been installed.**

Step	Check Point	Remedy
7	Is CN8 on the main board is disconnected or almost disconnected?	<p>Even though it is the same FFC, signals indicating the cartridge installation condition are not input to CN9.</p>  <p><b>NOTE:</b> If CN8 and CN9 are inserted at an angle or if they are almost disconnected from the connector, there is a high possibility that direct damage to the head may occur, and in the worst case, the head driving transistors (Q9 and Q10) on the main board and the print head itself may become damaged. Because of this, handle the FFC very carefully while working.</p> <p>When CN9 is disconnected and then reconnected and the power is turned back on, the fatal error is cleared, but if CN8 is disconnected, and the power is then turned back on, an unexpected Ink Out indication will appear and all of the currently-installed ink cartridges must be replaced. This is because CN8 includes the signal that is used to monitor the internal head temperatures, so that if CN8 is disconnected the voltage becomes 0 V, or in other words an abnormal temperature has been detected. Accordingly, the power should not be turned on while CN8 is disconnected in order to avoid wastage of the ink cartridges.</p>

**Table 3-7. This section describes the procedures for solving the problem when an ink out (cartridge out) error is displayed even though a brand-new ink cartridge has been installed.**

Step	Check Point	Remedy
8	Has a head hot error occurred?	<ol style="list-style-type: none"> <li>1. Install a new ink cartridge and check if the problem returns to normal. If it does return to normal, the head hot error is probably the fault of the customer. The approach to head hot errors has changed from the Stylus COLOR 900/980, so that with this printer there is no way to check the history of whether head hot errors have occurred or not by checking the specified address in the EEPROM. The differences in heat hot errors between this printer and the Stylus COLOR 900/980 are given below.             <ol style="list-style-type: none"> <li>1.1. The sequence for setting a flag inside the EEPROM to check if this is the 1st or 2nd occurrence has been eliminated.</li> <li>1.2. Because of the above, automatic cleaning does not immediately occur when the first head hot error occurs.</li> <li>1.3. However, if a heat hot error really has occurred, the ink consumption status is forced to 100% and an ink out error is displayed so that the current status of the ink cartridges can be checked.</li> </ol> </li> <li>2. Apart from head hot errors which are the fault of the customer, there is a danger that these errors can occur as a result of repair service activity.             <ol style="list-style-type: none"> <li>2.1. When the head is replaced, the TG value in the first digit of the head ID for the circuit board that is currently installed is ignored, and the power is turned on with the initial ink cartridges installed.</li> </ol> </li> <li>3. In conclusion, the ink cartridges must be replaced in the case of either item No. 1 and No. 2 above, but for the service problem in No. 2, use the adjustment program at the stage before inserting the cartridges to write the head ID for the currently-installed head to the EEPROM.</li> </ol>

**Table 3-7. This section describes the procedures for solving the problem when an ink out (cartridge out) error is displayed even though a brand-new ink cartridge has been installed.**

Step	Check Point	Remedy
9	Have the cartridges been refilled?	<p>Because this printer uses a new type of cartridge, traces of whether the cartridges have been refilled can basically be checked. The reasons are as follows.</p> <ol style="list-style-type: none"> <li>1. In contrast to previous CSICs, there is no ventilation hole at the top of the cartridge. There is no refill point like previously.</li> <li>2. If a syringe is inserted through the film to charge the inside of the cartridge with ink, a hole is made in the film, and so the customer must use measures such as applying tape in order to prevent ink from leaking out.</li> </ol>
10	The data in the ink cartridge CSIC chip (EEPROM) is corrupted.	<p>Of the many items of data stored in the CSIC chips, the only item that is updated by the printer is the ink consumption counter. If 100% is written to this address, the cause will be one of the following two reasons.</p> <ol style="list-style-type: none"> <li>1. Corrupt data in the CSIC chip. The cause of this might be as follows.                             <ol style="list-style-type: none"> <li>1.1. The data was recorded incorrectly when the CSIC chip was shipped from the factory (data is randomly corrupted).</li> <li>1.2. The CSIC chip was shipped without being initialized for some reason.</li> <li>1.3. The hand of the customer touched the chip while charged with static electricity, and this caused the data in the EEPROM to be randomized, so that the data became corrupted.</li> </ol> </li> <li>2. A head hot error as described in No. 7 occurred. In such cases, the data is not randomized as described above, but the only part of the CSIC data that is changed is the ink consumption counter. No data in any of the other addresses is affected.</li> </ol> <p><i>NOTE: Previous printers which adopted the CSIC and printers which used DC motors have a sequence which forcibly changed the consumption status to 100% for currently-installed ink cartridges as a result of customer error. However, this printer does not have such a function. Accordingly, CSIC problems relating to ink life should be analyzed based on the above points.</i></p>

### 3.1.4.3 Countermeasures when an Ink Low indication appears.

This section describes the procedures for solving the problem when an Ink Low indication is displayed unexpectedly. However, ink low indications can occur naturally while printing is in progress. This section covers cases when the ink cartridges have just been replaced but the Ink Low indication does not disappear, using an actual case of a claim received by a subsidiary from a customer as an example.

**Table 3-8. Countermeasures when an Ink Low indication does not disappear (Check conditions with customer)**

Step	Check Point	Remedy
1	Does the printer fail to recognize new ink cartridges immediately after the customer has installed new ink cartridges?	<p>When ink cartridges are replaced, the printer recognizes the presence of brand-new ink cartridges by the following procedure.</p> <p>Step1. The customer presses the replace button to move the carriage to the replacement position.</p> <p>Step2. The customer removes the cartridge which is currently showing an Ink Low or Ink Out status. If a cartridge showing an Ink Out status is removed at this time, the Ink Out indication does not change. If a cartridge showing an Ink Low status is removed, the Ink Out status (actually Cartridge Out) is momentarily displayed.</p> <p>Step3. A new ink cartridge is installed. At this time, the following differences occur depending on the situation.                      [If the cartridge replaced showed an Ink Out indication]                      The Ink Out indication remains even when a brand-new ink cartridge is installed.                      [If the cartridge replaced showed an Ink Low indication]                      The Ink Low indication remains even when a brand-new ink cartridge is installed.</p> <p>If the printer cannot recognize the new ink cartridge immediately after it is installed, it is because the printer is designed so that communication timing between the CSIC and the main unit is not carried out when the carriage is at the ink cartridge replacement position. If communication is carried out at the ink cartridge replacement position, removing and installing the cartridge would not write the data correctly, with the result that the data inside the EEPROM would be unreliable.</p>

### 3.1.4.4 Remedies for the Maintenance Error

If a maintenance error momentarily occurs, operation of the printer will not be possible. Because this is an error which occurs because the amount of ink discharged up until this time is close to the total absorption capacity of the ink pad, if operation continues past this point, there is the danger that the waste ink in the lower case may leak out. Because the adjustment program supports IEEE 1284.4, it includes a function for forcibly clearing this error. Accordingly, either a special panel operation at the printer or a reset operation using the adjustment software can be used to clear this maintenance error.

**Table 3-9. Countermeasures when a maintenance error occurs**

Step	Actions	Correct LED condition
1	While holding down both the Load/Eject switch and the Ink Maintenance switch, turn on the power.	The Paper Out LED will flash for 5 seconds. Step 2 must be started during this time.
2	Press and hold the Ink Maintenance switch for 10 seconds. When the printer accepts the maintenance error clearing function, all LEDs will momentarily light and the printer will then switch to standby mode.	Check that the two LEDs momentarily light and then turn off.

**NOTE:** Once the maintenance error has been cleared, the waste ink drain pad must be replaced. If it is not replaced, ink may leak out while the customer is using the printer.

**NOTE:** During the Step 2, if the Load/Eject button is pressed, the Maintenance Error is not cleared but the EEPROM initialization mode is activated instead. The EEPROM initialization can be used to recover from conditions such as the printer does not accept any data from the PC. The EEPROM initialization mode initializes the following items:

- Accumulated power-off time: The value for the Timer IC is reset.
- Timer IC (Stylus COLOR C80 only):  
The time during which the power is interrupted is continually counted until the energy of the capacitor located in the timer IC is dissipated. This timer IC is only equipped in the Stylus COLOR C80, so it does not apply to the Stylus COLOR C70. Moreover, the Stylus COLOR C70 has this power interrupt timer as part of the printer driver functions, and so the printer driver judges whether timer CL has been carried out and the level until the power is turned back on again.
- I/F selection: Selects "Auto", the factory default, from 4 I/F selection items: Auto, Parallel, Serial, and Option.

### 3.1.4.5 Remedies for Fatal Error

Fatal errors can occur with this printer for one of the following two reasons.

- When the status of the signal from the sensor to the main board indicates that there is a problem with the carriage motor operation and status.
- When the status of the signal from the sensor to the main board indicates that there is a problem with the paper feed motor operation and status.

A fatal error is basically caused by any of the following conditions:

1. The printer does not detect the carriage in the home position.
2. The printer does not detect signals from the linear scale.
3. The ASF sensor does not detect the ASF home position.

The following tables show various causes of the error and corresponding solutions. Be sure to follow the steps correctly to solve the problems.

**NOTE 1:** If the finding for the question is Yes, take the action described in the right column. If "No", proceed to the next step.

**NOTE 2:** Once the fatal error occurs, the adjustment program cannot communicate with the printer. Therefore, please eliminate a factor of the fatal error once, and then use the adjustment program if you want to need.



Table 3-10. Countermeasures when a fatal error occurs

Step	Check Point	Remedy
1	Is the linear scale not moving in between the photo sensor (photo coupler) parts on the underside of the carriage? (or is the area around the photo sensor clear of problems?)	<p><b>NOTE:</b> These countermeasures include ways to solve paper loading problems when there is dirt or other foreign materials on the linear scale, but paper jams may also occur depending on the level of dirtiness, so processing as a carriage error (fatal error) may also be required.</p> <p>If the linear scale does not move inside the photo sensor, a fatal error will occur. Check if the condition is as shown in the illustration below or not. If the linear scale is not inside the photo sensor, re-adjust the positions of the linear scale and photo sensor.</p>  <p>Look through the cut-away part of the mechanism at the home position side of the carriage and check if the encoder (photo coupler) is blocked with paper or dust. If it is blocked with paper or dust, use a cotton swab or similar to clean away the blockage.</p> <p>If the surface is dirty, remove the linear scale and clean it with a cloth moistened with alcohol.</p> 

Table 3-10. Countermeasures when a fatal error occurs

Step	Check Point	Remedy
2	Is the FFC disconnected or almost disconnected from the junction board on the underside of the carriage?	 <p>CN1 is the connector that handles the input and output of signals between the main board and the mechanism. It inputs the various encoder signals to the main board from the mechanism, and outputs head drive signals from the main board.</p>
3	Is the rotary scale not moving in between the PF encoder (photo coupler) parts? (or is the area around the photo sensor clear of problems?)	<p>If the rotary scale is not inside the photo sensor, the PF motor will operate at high speed and the mechanism may become overloaded, resulting in a fatal error. Check if the condition is as shown in the illustration below or not. If the rotary scale is not inside the photo sensor, re-adjust the rotary scale so that it is inside the photo sensor. Furthermore, check if the connector that transmits the signal from the rotary encoder to the main board is disconnected.</p> 
4	Check if CN12 (white: 4-pin) on the main board is disconnected.	<p>CN12 on the main board is a connector that transmits the feedback signal from the PF encoder to the main board. Accordingly, if this connector is disconnected, the result is the same as if there is a malfunction of the PF encoder.</p>

Table 3-10. Countermeasures when a fatal error occurs

Step	Check Point	Remedy
5	Is CN8 (FFC) on the main board disconnected or almost disconnected?	CN8 on the main board is a connector that transmits the feedback signal from the carriage encoder to the main board as well as transmitting the head drive signals. Accordingly, if this connector is disconnected, the result is the same as if there is a malfunction of the carriage encoder.
6	Is there a malfunction of the CR motor?	<p>Use an ohmmeter to check the resistance value of the coil inside the carriage motor. Resistance value: 23.3 ohms +/- 15% (DC)</p> <p><i>NOTE: Look carefully at the whole of the coverings of the two harnesses, and make sure that there are no holes anywhere in the coverings. If a hole is found anywhere, measure the internal coil resistance and replace just the harness if the resistance value is normal. (However, none of the harnesses for the spare parts motors are supplied as single parts.)</i></p> 

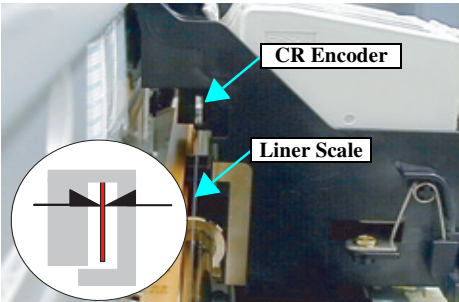
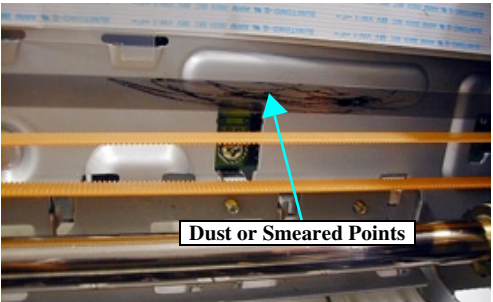
Table 3-10. Countermeasures when a fatal error occurs

Step	Check Point	Remedy
7	Is there a malfunction of the PF motor?	<p>Use an ohmmeter to check the resistance value of the coil inside the paper feed motor. Resistance value: 23.3 ohms +/- 15% (DC)</p> <p><i>NOTE: Look carefully at the whole of the coverings of the two harnesses, and make sure that there are no holes anywhere in the coverings. If a hole is found anywhere, measure the internal coil resistance and replace just the harness if the resistance value is normal. (However, none of the harnesses for the spare parts motors are supplied as single parts.)</i></p> 
8	Is there a malfunction of the motor driver IC (IC8) on the main board?	<p>If the pins of IC8 are blackened, the main board and the motor must both be replaced at the same time. Furthermore, in order to determine which motor, check the internal coil resistance of the motors as described in step 7 above, and replace whichever motor does not give a normal resistance value measurement (energization not possible, or abnormal current flow due to short). In addition, if there are no visible problems with the IC, replace the main board and then check the operation.</p> <p><i>NOTE: When the main board is replaced, several adjustments must be carried out, so refer to the "Adjustment" and "Disassembly" sections for details on carrying out these adjustments correctly.</i></p>
9	Is there a malfunction of the PF motor encoder (photo sensor)?	Replace the junction board that the encoder is mounted on, and check operation.

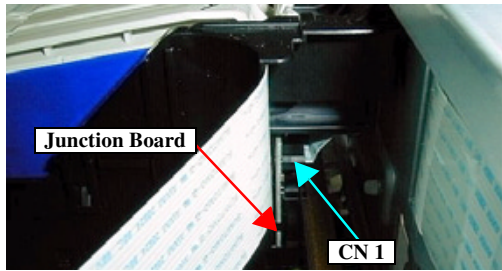
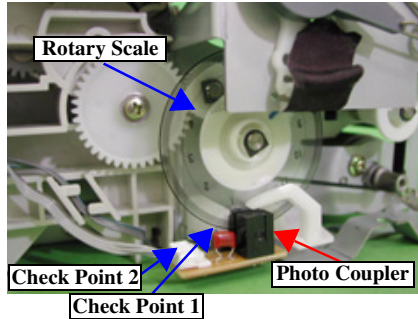
Table 3-10. Countermeasures when a fatal error occurs

Step	Check Point	Remedy
10	Is there a malfunction of the CR motor encoder (photo sensor)?	Replace the junction board on the underside of the carriage that the encoder is mounted on, and check operation.  <i>NOTE: Once the carriage or the carriage guide shaft have been removed, several adjustments must be carried out, so refer to the "Adjustment" and "Disassembly" sections for details on carrying out these adjustments correctly.</i>

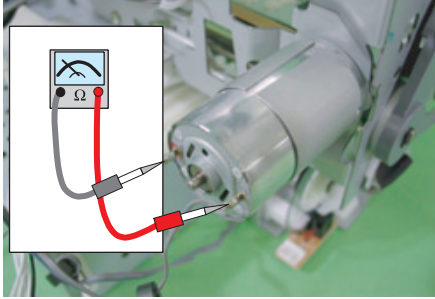
### 3.1.5 Isolating the Faulty Part on the Power Supply Board

This section explains how to troubleshoot the following problems:

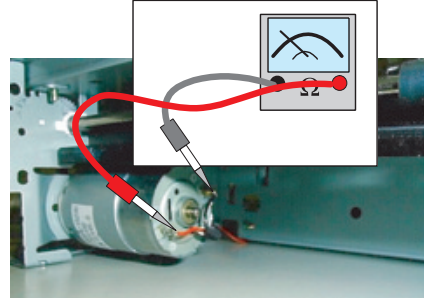
- The printer is turned on, but the initialization is not performed and LED on the control panel do not come on.

Be sure to perform troubleshooting in the order specified, because the parts involved are mentioned in the disassembly procedure to facilitate servicing.



- Be careful to avoid electric shocks when checking the electrical circuit boards (C424 MAIN-B, PSE and B circuit boards) while the power is turned on.
- When touching parts such as the FETs or the surface of the heat sink on the transistor with one hand, never touch other metallic parts of the mechanism with your other hand, as the chance of receiving an electric shock at such times is extremely high. The locations of particular danger are shown below.

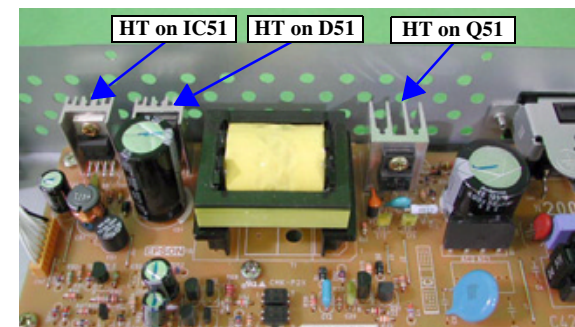
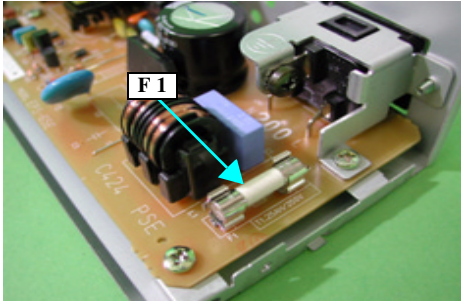

Table 3-11. Isolating the Faulty Part on the Power Supply Board

Step	Check Point	Remedy
1	Is the power supply stable?	When printers with a PSB board installed are used in countries where the power supply voltage is 200 V, the power supply board may become damaged. Furthermore, even if printers with a PSB board installed are used in countries where the power supply voltage is 100-120 V, the power supply board may not operate correctly if the power supply voltage is too low.

**Table 3-11. Isolating the Faulty Part on the Power Supply Board**

Step	Check Point	Remedy
2	Is CN19 (white 8-pin) on the main board loose or completely disconnected?	<p>Check that CN19 is not loose or disconnected. If it is loose or disconnected, reconnect it securely to the main board.</p> <p><i>NOTE: CN2 on the C424PSB/PSE board is soldered on so that it is not likely to come loose or be disconnected. However, the soldered joint may become broken if the printer is dropped or subjected to unexpectedly strong shocks, and this may result in the connector becoming loose.</i></p>
3	Is the fuse (F1) on the C424PSB/PSE board blown? (Visual check is possible.)	<p>If overcurrent (due to lightning or other voltage abnormalities) occurs, the fuse (F1) on the power supply board will blow. This can be checked visually. If F1 is found to have blown, replace only F1 and then check the operation again. If F1 blows again, there is probably a problem with the power supply board, and so the board should be replaced.</p> <p>If F1 continues to blow even after the power supply board is replaced, carry out the following steps.</p>  <ol style="list-style-type: none"> <li>1. Check the internal coil resistances of the CR/PF motors.</li> <li>2. Check that the print head FFC connections at the main board and the print head are normal. Furthermore, when checking the print head side, check that there are no burn residues on the head driver board.</li> <li>3. If the check in No. 2 above indicates a problem at either end, replace the main board, the power supply board, the print head and whichever motor showed a problem. Furthermore, if no problems were found, there is probably a problem with the main board, and so the main board and power supply board should be replaced.</li> </ol>

**Table 3-11. Isolating the Faulty Part on the Power Supply Board**

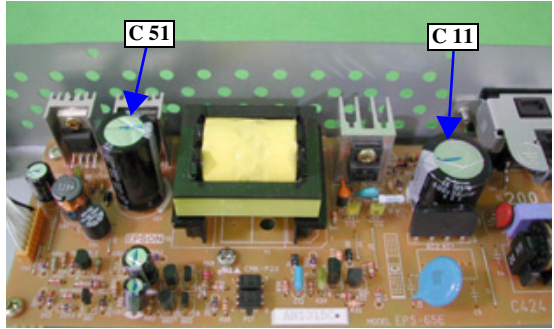
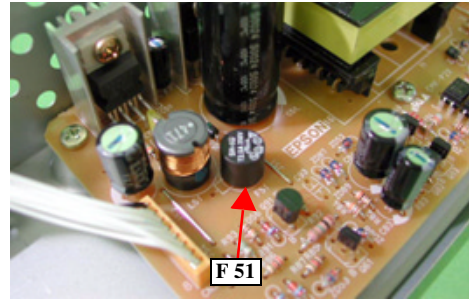
Step	Check Point	Remedy
4	Are any of the condenser breaker valves open (particularly C11 or C51)?	<p>C11 and C51 are the most likely places for this to happen. If the breaker valves are open, replace the power supply board. However, if problems with operation continue to occur after the power supply board is replaced, carry out steps 1 to 3 in procedure No. 2 above.</p> 
5	Are any conductive foreign particles such as metal shavings in between the power supply board and the shield plate?	<p>If insects get inside the printer, they can also cause problems with the power supply board. Also check if there are any foreign particles on the surface of the power supply board.</p>
6	Is F51 on the +42 V termination line blown?	<p>Check the continuity of F51. If it has blown, replace the power supply board.</p> 

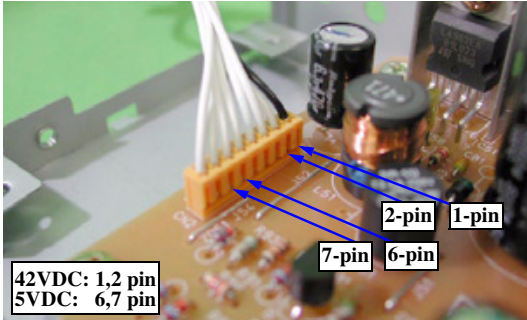

**Table 3-11. Isolating the Faulty Part on the Power Supply Board**

Step	Check Point	Remedy
7	Is a normal voltage being output from the power supply board?	<p>Measurement points are shown below.</p> <p>&lt;+42 V measurement&gt;</p> <ul style="list-style-type: none"> <li>• Positive tester probe: Pin 1, pin 2</li> <li>• Negative tester probe: Either pin 3, pin 4 or pin 8</li> </ul> <p>&lt;+5 V measurement&gt;</p> <ul style="list-style-type: none"> <li>• Positive tester probe: Pin 6, pin 7</li> <li>• Negative tester probe: Either pin 3, pin 4 or pin 8</li> </ul> 

**Table 3-11. Isolating the Faulty Part on the Power Supply Board**

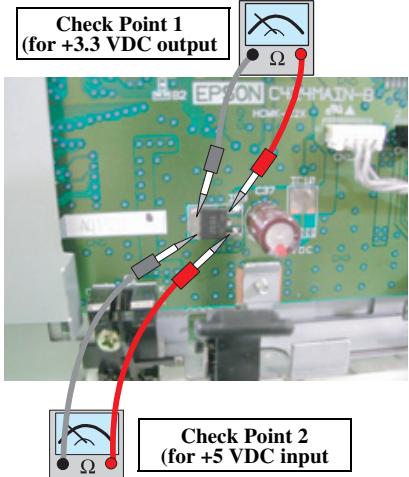
Step	Check Point	Remedy
8	Even though the power supply board is supplying a normal voltage, is the 3.3 V DC power supply voltage that is used to control the main board normal?	<p>Check whether the +5 V DC power supply voltage at IC9 on the main board is being supplied correctly or not, and whether the +3.3 V DC is being output normally from IC9.</p> 

If the problem does not disappear or if it cannot be reproduced when these checks are carried out, refer to "CR Motor Operation Abnormal" in Section 3.1.6.11.

### 3.1.6 Isolating the Faulty Part according to the Phenomenon

Refer to this section if you could not solve the problem in Section 3.1.4 or Section 3.1.5 or need more information to isolate the cause according to the exhibited phenomenon.

In models which use a DC motor, even if a problem occurs in the printer mechanism, the motor will keep operating if the current is within the rated level and no problem will be detected. The result of this is that the motor can keep operating without a fatal error being detected and without any mechanism problem being detected, so that a large amount of noise was produced. This section lists surface problems that occurred during inspections at the prototype stage and which might be considered to occur in the marketplace also.

**Table 3-12. Troubleshooting for surface problems**

Step	Surface problem	Reference page
1	<b>[PF Motor Driver Abnormal 1]</b> PF motor rotary encoder feeds paper at high speed in an unexpected manner that is different from normal operation, or paper jams always occur around the hopper.	Refer to Section 3.1.6.1.
2	<b>[ASF Driver Abnormal 1]</b> The PF motor operates normally, but the ASF is not being driven. (Paper is not being fed.)	Refer to Section 3.1.6.2.
3	<b>[Unexpected Ink Out (Cartridge Out) Error]</b> Dot dropout appears to be happening a lot, and then suddenly an Ink Out indication appears. However, the ink cartridges are almost new or are still quite full.	Refer to Section 3.1.6.3.
4	<b>[PF Motor Driver Abnormal 2]</b> Noise occurs around the PF motor each time the PF motor operates.	Refer to Section 3.1.6.4.
5	<b>[Carriage Operation Abnormal]</b> When the power is turned on, the carriage appears to move slightly, but then a fatal error occurs. (The fatal error always occurs at the same place.)	Refer to Section 3.1.6.5.

**Table 3-12. Troubleshooting for surface problems**

Step	Surface problem	Reference page
6	<b>[Dot Missing 1]</b> The carriage operates normally, but printing is not possible at all.	Refer to Section 3.1.6.6.
7	<b>[Dot Missing 2]</b> Specific nozzles are always missing or give an alignment failure even though cleaning is carried out.	Refer to Section 3.1.6.7.
8	<b>[Dot Missing 3]</b> All nozzles are firing, but printing is unstable.	Refer to Section 3.1.6.8.
11	<b>[Repair Handling Failure]</b> The ROM is to be replaced with a new one, but immediately after the power is turned on a fatal error occurs.	Refer to Section 3.1.6.9.
12	<b>[ASF Driver Abnormal 2]</b> The LD roller shaft inside the ASF rotates normally when the PF motor operates, but the paper cannot be fed properly, or a large amount of noise is heard.	Refer to Section 3.1.6.10.
13	<b>[CR Motor Operation Abnormal]</b> A printer which has performed well up until a certain time suddenly changes in printing speed so that printing time becomes much longer.	Refer to Section 3.1.6.11.

### 3.1.6.1 PF Motor Driver Abnormal 1

This section describes the procedures for solving the problem when no error occurs, but only the PF motor operates at high speed all the time even though this has not happened before. The PF motor is different from the carriage motor in that it does not generate a fatal error even if the rotary encoder cannot read at all, so that the firmware checks the bar code signal on the rotary encoder and continues providing current to the PF motor, causing it to operate at high speed. The methods of solving this problem are given below in order starting from the easiest, so refer to them for the checking and working procedures.

**Table 3-13. PF Motor Driver Abnormal 1**

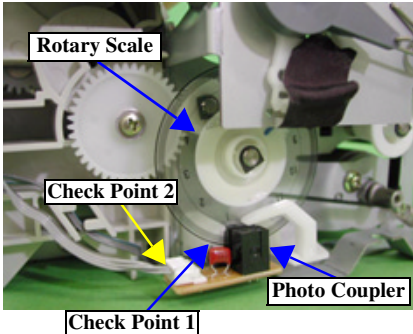
Step	Check Point	Remedy
1	Is the rotary scale not moving in between the PF encoder (photo coupler) parts? (or is there a problem around the photo sensor?)	<p>If the rotary scale is not inside the photo sensor, a fatal error will occur. Check if the condition is as shown in the illustration below or not. If the rotary scale is not inside the photo sensor, re-adjust the rotary scale so that it is inside the photo sensor. Furthermore, check if the connector that transmits the signal from the rotary encoder to the main board is disconnected.</p> 
2	Check if CN12 (white: 4-pin) on the main board is disconnected.	CN12 on the main board is a connector that transmits the feedback signal from the PF encoder to the main board. Accordingly, if this connector is disconnected, the result is the same as if there is a malfunction of the PF encoder.
3	Is there a malfunction of the photo coupler junction board?	Replace the junction board shown in the above photograph and then check the operation.

### 3.1.6.2 ASF Driver Abnormal 1

This section describes the procedures for solving the problem when no error occurs, but the ASF is not driven at all even though the PF motor operates normally. This problem occurs because the ASF and the printer mechanism are not engaged correctly. The methods of solving this problem are given below in order starting from the easiest, so refer to them for the checking and working procedures.

**Table 3-14. ASF Driver Abnormal 1**

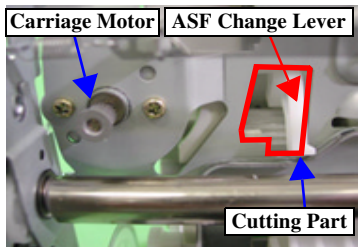
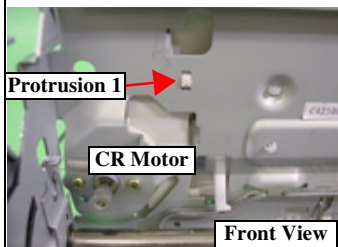
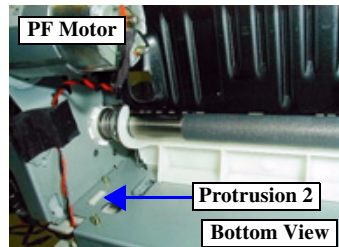
Step	Check Point	Remedy
1	Is the ASF installed correctly to the printer mechanism?	<p>Check all of the following points.</p> <p>1. Is the ASF change lever protruding from the cut-away part at the front of the mechanism?</p>  <p>2. Are the two protrusions at the left side of the ASF left side frame correctly visible from the cut-away part of the mechanism? (If it is not protruding, it needs to be reset.)</p>  

**Table 3-14. ASF Driver Abnormal 1**

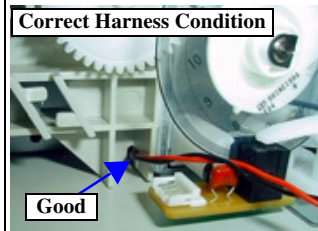
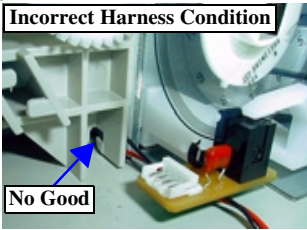
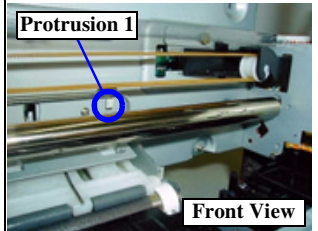
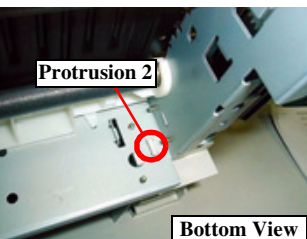
Step	Check Point	Remedy
1 (Cont.)	Is the ASF installed correctly to the printer mechanism?	<p>3. The PF motor harness routed correctly? If the harness is routed incorrectly as shown in the illustration below, there will be a gap between the ASF and the printer mechanism, and the gears will not engage correctly. Furthermore, the PF motor harness may also develop an open circuit.</p>   <p>4. Are the two protrusions at the left side of the ASF left side frame correctly visible from the cut-away part of the mechanism?</p>  



### 3.1.6.3 Unexpected Ink Out Error 1 (During Print Operation)

This section describes the procedures for solving the problem when unexpected Ink Out errors occur. However, the problem described here is separate to the problem described before when an Ink Out error occurred even though the ink cartridges had just been replaced with new ones. This section covers Ink Out errors caused by head hot errors which can occur when printing continues while several of the nozzles are missing. The only way to solve this problem is to replace the ink cartridges, so this section mainly describes the process by which the error occurs.

**Table 3-15. Unexpected Ink Out Error 1 (During Print Operation)**

Explanation step	Head hot error requirements, process and countermeasures
1	<p>A new head hot sensor function has been added to the Stylus COLOR 900/980. The background to this is given below.</p> <ol style="list-style-type: none"> <li>Nozzles (number of internal PZTs) were added to cope with the increase in printing speed.</li> <li>The print head drive frequency was increased.</li> </ol> <p>Under the above conditions, the head becomes extremely hot when ink cannot be supplied to the head, and in the worst case the PZTs can seize in the same way as a vehicle engine.</p>
2	<p>The Stylus COLOR 900/980 does not have a CSIC, so removal and reinstallation of prohibited ink cartridges caused the ink consumption counter to become inaccurate, so that even if there was not even a single drop of ink in a cartridge, the printer firmware would detect this incorrectly and would cause printing characters to be generated at the print head with the danger of the condition in No. 1 above occurring, and the result would be damage to the PZTs.</p>

**Table 3-15. Unexpected Ink Out Error 1 (During Print Operation)**

Explanation step	Head hot error requirements, process and countermeasures
3	<p>To prevent this from happening, the Stylus COLOR 900/980 detected the temperature at each color nozzle, and if more than half of the nozzles in a nozzle line become blocked, and if printing is continuing, then the data for this rise in temperature caused by this abnormal condition was detected, causing the following sequence to occur.</p> <ol style="list-style-type: none"> <li>Abnormal temperature is detected. (At this time the actual temperature inside the head is approximately 100°C.)</li> <li>Printing of the current character data is momentarily stopped.</li> <li>After this, cleaning (CL1) starts automatically.</li> <li>Printing of the current character data resumes. If no abnormal temperature is detected after this and the power is then turned off, the history data indicating that an abnormal temperature was detected is cleared.</li> <li>If printing is carried out again (before the power is turned off), and if a high temperature is detected again at this time, it is judged that the ink cartridges in the printer are completely empty and Ink End is set.</li> </ol>
4	<p>The Stylus COLOR C70/C80 have the same function written into their firmware, but the following points are completely different to those for the Stylus COLOR 900/980.</p> <p>When an abnormal temperature is detected, an Ink Out condition is immediately set, and the ink consumption counters for the currently-installed ink cartridges are set to 100%, so that the only way to reset the problem is to install new ink cartridges.</p> <p>The reasons for changing the sequence in this way are as follows.</p> <ol style="list-style-type: none"> <li>Actual market results show that problems related to heat hot errors and customer confusion never occurred.</li> <li>Points to note during head replacement were strictly observed by Epson subsidiaries and their partners, and so no repair problems ever occurred.</li> <li>The Stylus COLOR 900/980 used conventional ink cartridges which were not of a CSIC type, so that the amount of ink actually remaining in ink cartridges and the amount of ink remaining as understood by the printer firmware was liable to cause counter mismatches due to incorrect operations carried out by customers, but with this product the cartridges can be installed and removed freely.</li> </ol>
5	<p>Accordingly, the occurrence of head hot errors is extremely rare in the new models, and basically the only problem that can be expected is counter mismatches due to refilling.</p>

### 3.1.6.4 PF Motor Driver Abnormal 2

This section describes the procedures for solving the problem when no error occurs, but only the PF motor operates at high speed all the time even though this has not happened before. The PF motor is different from the carriage motor in that it does not generate a fatal error even if the rotary encoder cannot read at all, so that the firmware checks the bar code signal on the rotary encoder and continues providing current to the PF motor, causing it to operate at high speed. The methods of solving this problem are given below in order starting from the easiest, so refer to them for the checking and working procedures.

**Table 3-16. PF Motor Driver Abnormal 2**

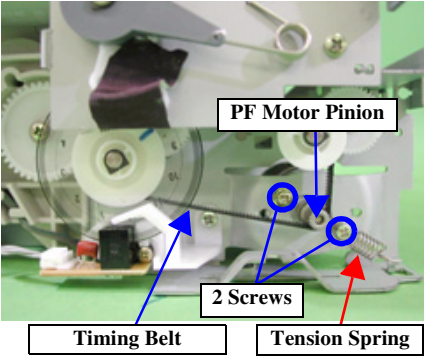
Step	Check Point	Remedy
1	Is the belt tension appropriate (is it not too loose) even though the PF motor operates normally?	<p>If the belt tension cannot be checked to see if it is normal just by touching it, reset the belt tension by the following procedure.</p> <ol style="list-style-type: none"> <li>1. Remove the tension spring that is attached to the screw securing the PF motor.</li> <li>2. Loosen the two screws that are securing the PF motor. (They do not need to be removed.)</li> <li>3. Remove the timing belt from the pinion gear.</li> <li>4. Set the timing belt onto the pinion gear.</li> <li>5. Attach the tension spring to one of the screws securing the PF motor.</li> <li>6. Tighten the screw which was attached to the spring in the step above.</li> <li>7. Tighten the other screw.</li> </ol> 

**Table 3-16. PF Motor Driver Abnormal 2**

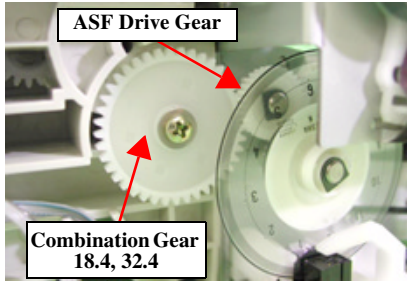
Step	Check Point	Remedy
2	Are the ASF transmission gear and the combination gears 18.4 and 32.4 at the ASF engaged correctly?	<p>When the combination gear is gently turned clockwise and counterclockwise by hand, check that the ASF drive gear also moves. To check a whole revolution, set the ASF change lever to the active position and turn the timing belt or the PF motor pinion gear to check the operation.</p> 

### 3.1.6.5 Carriage Operation Abnormal

This section describes the procedures for solving the problem when a fatal error occurs as soon as the power is turned on and the printer stops operating. The methods of solving this problem are given below in order starting from the easiest, so refer to them for the checking and working procedures.

**Table 3-17. Carriage Operation Abnormal**

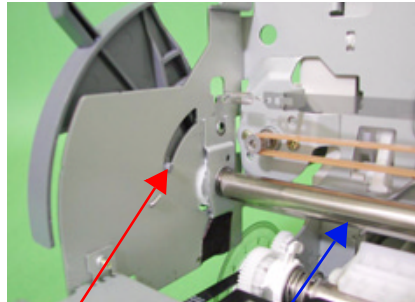
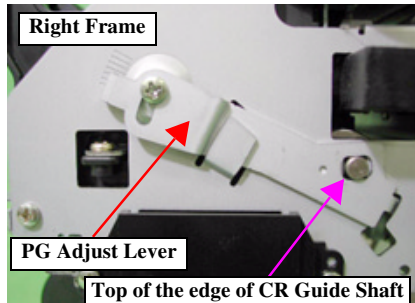
Step	Check Point	Remedy
1	Has the left end of the carriage guide shaft that is supported by the PG lever come away from the mechanism and fallen down?	<p>The PG lever which can be operated by the customer is secured to the cut-away section of the printer mechanism. If the lever becomes separated from this point, the carriage guide shaft will also be separated from the mechanism so first check the hooks of the PG lever and make sure that they are securely fastened.</p>  <p>PG Lever Hooks      Carriage Guide Shaft</p>
2	Is the right end of the carriage guide shaft also attached correctly to the frame in the same way as above?	<p>The photograph below shows the right end of the carriage guide shaft in its correct position. The end of the shaft that is protruding from the frame is secured by means of the notch in the PG adjust lever.</p>  <p>Right Frame PG Adjust Lever Top of the edge of CR Guide Shaft</p>

**Table 3-17. Carriage Operation Abnormal**

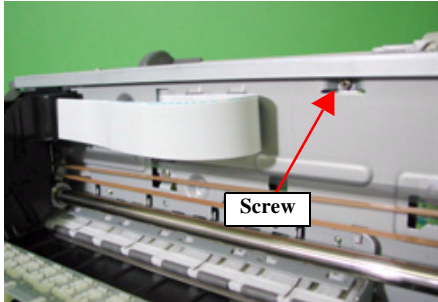
Step	Check Point	Remedy
3	Were any screws not fastened when the circuit board was replaced? (Service problem)	<p>The photograph shows a screw which is located in a place where it can obstruct movement of the carriage.</p>  <p>Screw</p>
4	Has PG adjustment been carried out correctly? (Service problem)	<p>While referring to "Chapter 5 Adjustment", carry out PG adjustment if any parts or units which require PG adjustment to be done have been replaced or removed.</p>

**Table 3-17. Carriage Operation Abnormal**

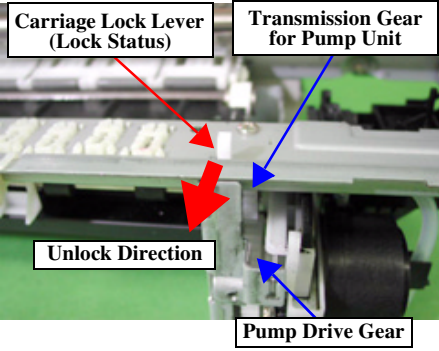
Step	Check Point	Remedy
5	Does the carriage lock lever operate normally?	<p>If the carriage lock lever cannot be operated when it is still in the active position, the carriage cannot move in the printing area direction. When the power is turned on, check that the carriage lock lever is moved to the unlock position before the carriage starts moving.</p> <p>[Cause 1] The carriage lock lever is not correctly protruding from the notch in the EJ frame.</p> <p>[Cause 2] The EJ roller shaft is not correctly secured by bushing 5, or the PF motor drive is not being transmitted correctly.</p> <p>[Cause 3] The pump unit is not secured correctly to the frame, and when the gear load increases, the carriage lock lever cannot be operated. In this case, the EJ roller shaft also will not rotate.</p> 

### 3.1.6.6 Dot Missing 1

This section describes the procedures for solving the problem when the printer is printing, but no print actually appears on the paper. Because this covers situation when the nozzles are not firing correctly for even one dot to be printed, and so it is separate from cases where several dots are fired normally. In this case, you should refer to the next section (3.1.6.7). The following symptoms for which results can be expected from checking.

1. Only black ink is not firing at all.
2. Only colored inks (CMY) are not firing at all.
3. None of the colors are printing at all.

Table 3-18. Dot Missing 1

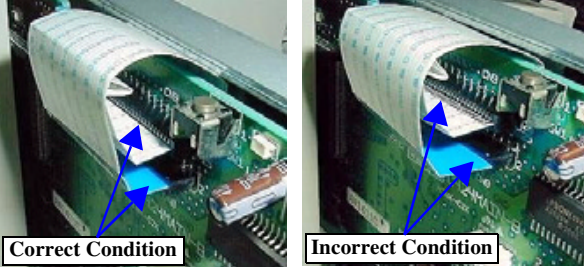
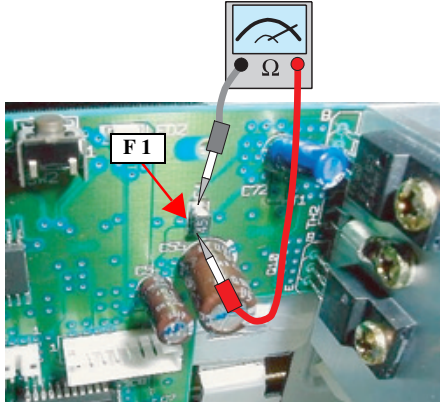
Step	Check Point	Remedy
1	Is either CN8 or CN9 connected at an angle or disconnected? (This is difficult to ascertain visually, so be sure to re-seat the FFCs.)	<p>The illustrations below show connectors CN8 and CN9 which affect printing. Be sure to disconnect the AC cable and then re-seat it. When re-seating the cable, press the FFCs by hand to see if they can be pushed in any further. If they can, then the FFC connections to CN8 and CN9 are probably loose, even if they are not inserted at an angle. If this is the case, problems with printing will occur.</p> 
2	Is the fuse (F1) that is located in the 42 V line that is supplied to the print head blown?	<p>Use an ohmmeter to check the continuity of F1. If there is no continuity, replace the circuit board or the fuse.</p> 
3	Are the FFC connected to the print head normal? Check the FFC by the procedure in step 1.	<p>Check the insertion of the two FFCs while referring to "Print Head" in Chapter 4. If there are traces of smoke on the junction board on the head, that print head cannot be reused. Furthermore, in such cases, the print head and the main circuit board should be replaced together in order to prevent the possibility of secondary damage.</p>

### 3.1.6.7 Dot Missing 2

This section describes the procedures for solving the problem when a specific nozzle is not firing (dots are missing). If none of the nozzles are firing and nothing is printing, refer to the previous section.

If a specific nozzle is not firing and the dots are missing, basically nozzle cleaning should be carried out, so that the cleaner blade can clean the surfaces of the nozzles and some ink can be drawn out of the ink cartridge. This is often an effective way to remedy the problem. Therefore the procedure below should be followed.

**Table 3-19. Dot Missing 2**

Step	Check Point	Remedy
1	Press the Ink maintenance switch on the printer to start cleaning.	Check that the mis-firing nozzle(s) gradually return to normal. If they do appear to be returning to normal, repeat the cleaning process until they are fully clean. If they do not appear to be returning to normal, proceed to step 2. Furthermore, the dummy cleaning operation that was used in older models is not supported by this model, so there is no problem with carrying out cleaning operations repeatedly.

**Table 3-19. Dot Missing 2**

Step	Check Point	Remedy
2	Can the cap unit operate normally?	<p>Press the part shown below by hand and check that it moves and that the cap unit automatically returns.</p>  <p>Checking method if there is a problem with operation</p> <ol style="list-style-type: none"> <li>1. Check that the two screws that are securing the cap unit to the right side of the mechanism are correctly securing the cap unit, and check that the positioning protrusion and the hole at the top of the cap unit are aligned.</li> <li>2. Check that the hooks of the cap unit are correctly secured to the middle frame.</li> <li>3. Check that the spring at the bottom of the cap unit is not detached. Also check that the drain ink tube is attached correctly to the bottom of the cap.</li> </ol>  <p>Check for No. 1</p>



Table 3-19. Dot Missing 2

Step	Check Point	Remedy
2 (Cont.)	Can the cap unit operate normally?	 <p>Check for No. 2</p>  <p>Check for No. 3</p>

Table 3-19. Dot Missing 2

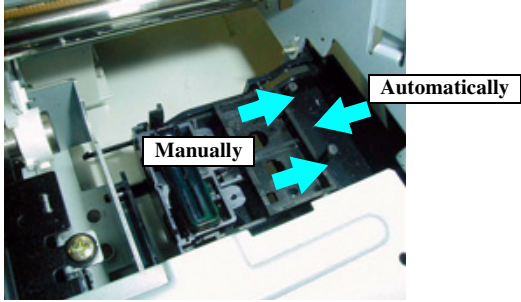
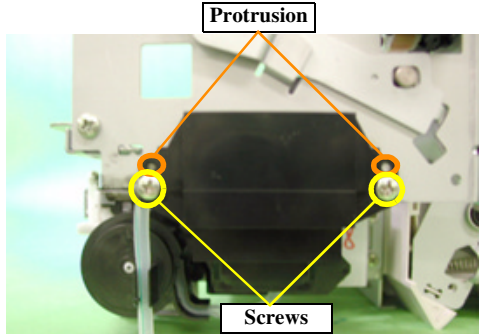
Step	Check Point	Remedy
3	Is there any dust or other foreign matter on the cap? And is the cap free from damage and deformation?	<p>If there is any dust or foreign matter on the edge of the cap as shown below, then the head and the cap will not seal together correctly and ink will not be suctioned correctly. If dust or other foreign matter is present, use a cotton swab or similar to clean it all off.</p> <p>Furthermore, if the edge of the cap has been damaged in some way, it will interfere with suctioning of the ink, and air may be drawn into the head. If this has happened, replace the whole of the cap unit.</p>  <p>After carrying out all checks, carry out cleaning once more and check if the problem is solved.</p>
4	Use the adjustment program to carry out forced cleaning (CL3) and check if printing returns to normal.	Check that the mis-firing nozzle(s) gradually return to normal. If they do appear to be returning to normal, repeat the CL3 cleaning procedure using the adjustment program until the nozzles are all fully clean. If they do not appear to be returning to normal, proceed to step 5.
5	Use the adjustment program to reset the initial ink charge flag to force cleaning using the initial ink charge.	Check that the mis-firing nozzle(s) gradually return to normal. If they do appear to be returning to normal, repeatedly reset the initial ink charge flag and turn the power on using the adjustment program until the nozzles are all fully clean. If they do not appear to be returning to normal, proceed to step 6.

Table 3-19. Dot Missing 2

Step	Check Point	Remedy
6	Let the printer stand for a day (if time permits).	After leaving the printer for a day, (In worst case, 3 to 4 days are required.) check if the missing printing appears to be returning to normal. If it does appear to be returning to normal, use the cleaning function on the panel, and the CL3 cleaning function and initial ink charge flag reset function of the adjustment program and check the progress. If it does not appear to be returning to normal, proceed to step 7.
7	Replace the print head.	—

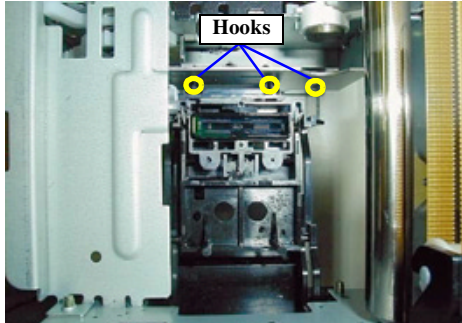
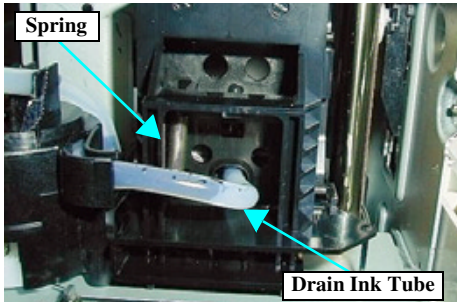
### 3.1.6.8 Dot Missing 3

This section describes the procedures for checking the following factors which can cause instability in printing even though all nozzles are firing ink normally. Carry out the steps in the order given.

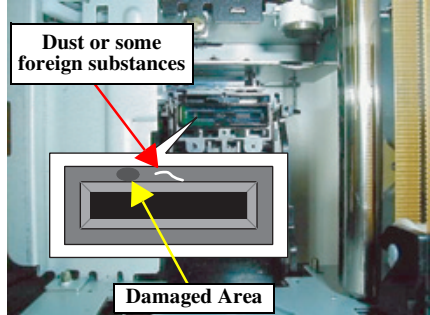
1. Characters are not sharply defined.
2. Horizontal and vertical lines are not straight.
3. White stripes or colored stripes are easily visible after high-speed printing.

Table 3-20. Dot Missing 3

Step	Check Point	Remedy
1	Have any parts or units relating to the carriage guide shaft been removed or replaced?	Carry out PG adjustment. Refer to Chapter 5 for details. If this does not apply, proceed to step 2.
2	Has a head ID been recorded?	If no head ID has been input, the TG value combination will fortunately not result in a head hot error, but the voltages and frequency correction data that are appropriate for that head will not be stored on the main board, and so the control carried out will not match the head's performance and unstable printing may result. Refer to Chapter 5 for details.
3	Has the head been replaced?	If angle adjustment has not been carried out, it should be carried out. Refer to Chapter 5 for details. If the head has not been replaced, proceed to step 4.
4	Carry out Bi-D adjustment.	Refer to Chapter 5 for details.
5	Carry out PF adjustment.	Refer to Chapter 5 for details.  <i>NOTE: PF adjustment is an effective adjustment function for high-speed paper feeding. It is an adjustment function for when the high-speed settings for Economy mode printing when print quality is not a problem and for Normal mode printing are carried out using the printer driver. Accordingly, it is an adjustment that cannot be expected to have an effect on printing problems during high-quality printing.</i>
6	Do the uneven parts of characters only appear in a certain raster?	Because it is possible that the printer has received a severe shock in the case of a specified raster, check this with the customer. If the carriage encoder receives a severe shock and momentarily stops reading, it may cause a direct ink firing timing fault even if it does not result in a fatal error, and this can cause character distortion for a particular raster.  If the printer has not received a severe shock and printing can be carried out once more, the problem is not reproduced again.



### 3.1.6.9 Repair Handling Failure

This section describes the procedures for checking when a fatal error occurs when the power is first turned on after the main board has been replaced. There is one cause for this.

**Table 3-21. Repair Handling Failure**

Step	Check Point	Remedy
1	Has the main board for the Stylus COLOR C80 or C70 been installed by mistake because the boards have the same name?	The EEPROMs on each board contain the model name data. When the power is turned on, the model name data that is stored in the ROM and the EEPROM data are compared and checked, and if the model name is incorrect, the printer develops a fatal error.

**NOTE:** The unexpected ink out error which can occur when there is a mismatch between the print head ID and the TG value in the EEPROM on the main board does not occur when the main board is replaced with a spare part board. This is because the default value recorded in the main board is "SHARP", and so the combination of the main board being "EPSON" and the head being "SHARP" which would otherwise cause an error does not occur.

### 3.1.6.10 ASF Driver Abnormal 2

This section describes the ASF operation problems mentioned before in more depth. The ASF problems that were mentioned previously dealt mainly with problems with the structural parts on the right side of the ASF, but this section covers the procedures for checking the causes of problems around the clutch mechanism. Most problems that occur around the clutch mechanism involve noise. Follow the procedures below to carry out the necessary checks.

**Table 3-22. ASF Abnormal 2**

Step	Check Point	Remedy
1	Does noise occur in the ASF just as the paper is being fed? Does noise occur during hopper reset when the ASF is driven in the reverse direction to paper feeding?	<p><b>[Abnormal noise during paper feeding]</b> If the noise occurs at the point where the ASF starts operating in the paper feed direction, carry out the checks in step 16 to step 19 of Section 3.1.4.1 or 3.1.6.2.</p> <p><b>[Abnormal noise during hopper reset (reverse drive)]</b> 1. Check that the change lever for driving the ASF is correctly installed to the shaft of the ASF. To check this, refer to the illustrations below. If the end of the shaft is visible at point A, then it is set correctly. If the end of the shaft is not visible at point B, the ASF change lever has come loose from the shaft, and it should be pushed back on again. Also check that the torsion spring is not loose or disconnected.</p> <p>Explanation: If the ASF change lever comes loose, the stopper function for the clutch will not work at all, so the LD roller shaft will keep turning but paper will not be fed when required.</p> 

Table 3-22. ASF Abnormal 2

Step	Check Point	Remedy
1 (Cont.)	Does noise occur in the ASF just as the paper is being fed? Does noise occur during hopper reset when the ASF is driven in the reverse direction to paper feeding?	<p>2. When the ASF is driven in the reverse direction to paper feeding (during hopper reset and back feeding), check that the planetary gear always lifts up.</p> <p><b>[Analysis points]</b></p> <p>A. The photograph shows the planetary gear lowered, and the lever of the planetary gear set is obstructing the ASF change lever, so that the planetary gear cannot move from this position regardless of whether the motor is running in forward or reverse.</p> <p>B. However, when the carriage contacts the ASF change lever, the lever of the planetary gear set is released, so that the planetary gear is lifted up (yellow arrow).</p> <p>C. At this time, the LD roller shaft is double driven by gear 1 and by gear 2 which is hidden behind gear 1.</p> <p>D. In this case, the gear that drives gear 1 is the planetary gear, and the gear that drives gear 2 is the transmission gear.</p>  <p>When paper is being fed and when the power is turned on and off, double feeding of the ASF is always carried out. Furthermore, the angle of the above photograph is a view from the right side of the printer with the ASF mechanism removed, to allow the mechanism to be checked easily. If the planetary gear is not lifted up, the probable cause is one of the following.</p> <p><b>[Cause 1]</b> The tension of the spring that applies a load inside the planetary gear is too strong and the planetary gear cannot lift up.</p> <p><b>[Cause 2]</b> The friction of the shafts that pass through the planetary gear set is too strong and the planetary gear cannot lift up.</p> <p><b>[Cause 3]</b> The ASF change lever is not installed correctly, so that even when the carriage contacts the change lever, it does not move and so the clutch remains engaged.</p>

Table 3-22. ASF Abnormal 2

Step	Check Point	Remedy
2	Does the PF motor operate without the LD roller inside the ASF unit rotating regardless of the ASF control operations?	<p><b>[Check for disconnected clutch (tension) spring]</b></p> <p>While referring to the photograph below, check that the tension spring is attached correctly to the clutch gear inside the ASF unit. To check, turn off the power and turn the timing belt that is attached to the pinion gear of the PF motor. At this time, you must move the ASF change lever manually so that it is in the same position as if the carriage is pressing against it. This check can be carried out by looking into the left side of the ASF unit from the right side of the printer with just the upper case removed.</p> <p><b>[Explanation]</b></p> <p>For the check in step 1 above, if the ASF lever is at the normal position, the LD roller will always rotate when the PF motor operates regardless of whether ASF control is in progress or not, even if the clutch tension spring is disengaged. In other words, the operation is the same as if the carriage is always pushing against the ASF change lever.</p> 

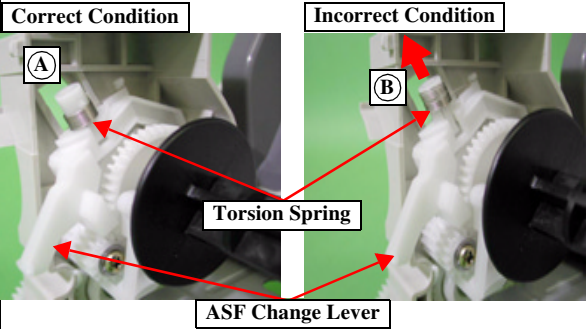
### 3.1.6.11 CR Motor Operation Abnormal

This section describes the procedures for checking printers that have been returned because the printing speed suddenly became much slower after having operated normally up until then. This problem basically cannot be immediately reproduced when carrying out repairs. This description concentrates on why problem occurs. To remedy the problem, canceling the transmission of printing data or turning off the power, wait about 15 minutes and then start printing again. Printing should then return to normal speed. This resetting method should be taught to the customer.

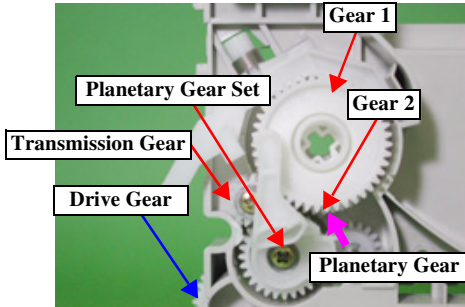
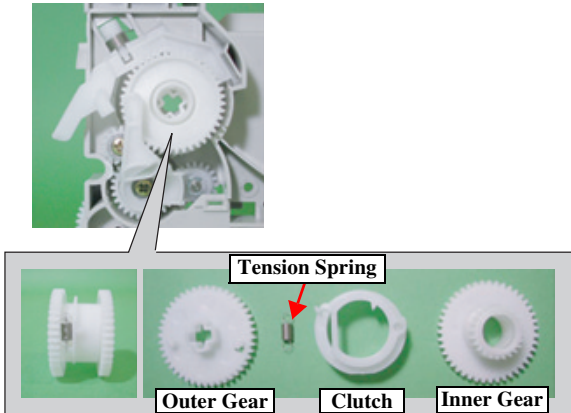
**Table 3-23. CR Motor Operation Abnormal**

Step	Check Point	Remedy
1	Is no problem apparent when printing is carried out?	If a problem is found, refer to the appropriate section of surface problems and take the appropriate measures. If no problem is found, continue to the next step.
2	Check the customer's usage environment.	<p>When DC motors are continually used, they become hot, and if they become too hot it can cause the coil inside the motor to seize. To prevent this from happening, the Stylus COLOR C70/C80 carries out the following controls.</p> <ol style="list-style-type: none"> <li>1. If continuous printing is carried out for 150 pages and printing continues past this, the carriage drive speed does not change but a 3-second waiting time is introduced after each pass is completed. This always occurs when the carriage moves from left to right or from right to left.</li> <li>2. In addition to the above condition, the same operation is performed if printing has been carried out continuously for 35 minutes, even if the number of continuous pages printed does not reach 150.</li> </ol> <p><i>NOTE: This operation causes the printing speed to remain at the slow speed without returning to normal as long as the current print job continues. If the speed does not automatically return to normal, it is different from the SIDM Print Head protection operation.</i></p>
3		To return the printing speed to normal from the above, momentarily pause the transmission of printing data from the computer, or turn the printer's power off and wait 15 minutes. The speed will then return to normal.
4		Make sure that the customer understands the above conditions, and show them the relevant sections of the User's Guide so that they understand how the printer's protection operation works.

CHAPTER

4

**DISASSEMBLY AND ASSEMBLY**

## 4.1 Overview

---

This section describes procedures for disassembling the main components of the product. Unless otherwise specified, disassembly units or components can be reassembled by reversing the disassembly procedure. Things, if not strictly observed, that could result in injury or loss of life are described under the heading “Warning”. Precautions for any disassembly or assembly procedures are described under the heading “CAUTION”. Chips for disassembling procedures are described under the heading “CHECK POINT”.

If the assembling procedure is different from the reversed procedure of the disassembling, the procedure is described under the heading “REASSEMBLY”.

Any adjustments required after disassembling the units are described under the heading “ADJUSTMENT REQUIRED”. When you have to remove any units or parts that are not described in this chapter, refer to the exploded diagrams in the appendix.

Read precautions described in the next section before starting.

### 4.1.1 Precautions

See the precautions given under the handling “WARNING” and “CAUTION” in the following column when disassembling or assembling the product.



- **Disconnect the power cable before disassembling or assembling the printer.**
- **If you need to work on the printer with power applied, strictly follow the instructions in this manual.**
- **Wear protective goggles to protect your eyes from ink. If ink gets in your eye, flush the eye with fresh water and see a doctor immediately.**
- **Always wear gloves for disassembly and reassembly to avoid injury from sharp metal edges.**
- **To protect sensitive microprocessors and circuitry, use static discharge equipment, such as anti-static wrist straps, when accessing internal components.**
- **Never touch the ink or wasted ink with bare hands. If ink comes into contact with your skin, wash it off with soap and water immediately. If irritation occurs, contact a physician.**



- **Avant de commencer, assurez vous que l'imprimante soit éteinte et que le cordon d'alimentation soit débranché.**
- **Veillez à jeter les piles usagées selon le règlement local.**

## CAUTION



- Never remove the ink cartridge from the carriage unless this manual specifies to do so.
- When transporting the printer after installing the ink cartridge, be sure to pack the printer for transportation without removing the ink cartridge.
- Use only recommended tools for disassembling, assembling or adjusting the printer.
- Observe the specified torque when tightening screws.
- Apply lubricants and adhesives as specified. (See Chapter 6 for details.)
- Make the specified adjustments when you disassemble the printer.  
(See Chapter 5 for details.)
- When assembling, if an ink cartridge is removed and needs to be installed again, be sure to install a new ink cartridge because of the following reasons;
  1. Once the ink cartridge mounted on the printer is removed, air comes in and creates bubbles in the cartridge. These bubbles clog ink path and cause printing malfunction.
  2. If an ink cartridge in use is removed and is reinstalled, ink quantity will not be detected correctly since the counter to check ink consumption is cleared.
- Because of the reasons above, make sure to return the printer to the user with a new ink cartridge installed.
- Make sure the tip of the waste ink tube is located at correct position when reassembling the waste ink tube. Otherwise it will cause ink leakage.

## 4.1.2 Tools

Use only specified tools to avoid damaging the printer.

**Table 4-1. Special Tool List**

Name	Supplier	Parts No.
Phillips Screw Driver (No.1)	EPSON	B743800100
Phillips Screw Driver (No.2)	EPSON	B743800200
Tweezers	EPSON	B741000100

### 4.1.3 Work Completion Check

If any service is made to the printer, use the checklist shown below to confirm all works are completed properly and the printer is ready to be returned to the user.

**Table 4-2. Work Completion Check**

Classification	Item	Check Point	Status	
Main Unit	Self-test	Is the operation normal?	<input type="checkbox"/> Checked	
			<input type="checkbox"/> Not necessary	
	On-line Test	Is the printing successful?	<input type="checkbox"/> Checked	
			<input type="checkbox"/> Not necessary	
	Printhead	Is ink discharged normally from all the nozzles?	<input type="checkbox"/> Checked	
			<input type="checkbox"/> Not necessary	
	Carriage Mechanism	Does it move smoothly?	<input type="checkbox"/> Checked	
			<input type="checkbox"/> Not necessary	
			Is there any abnormal noise during its operation?	<input type="checkbox"/> Checked
				<input type="checkbox"/> Not necessary
	Is there any dirt or foreign objects on the CR Guide Shaft?	<input type="checkbox"/> Checked		
		<input type="checkbox"/> Not necessary		
	Paper Feeding Mechanism	Is the CR Motor at the correct temperature? (Not too heated?)	<input type="checkbox"/> Checked	
			<input type="checkbox"/> Not necessary	
Is paper advanced smoothly?			<input type="checkbox"/> Checked	
			<input type="checkbox"/> Not necessary	
Is the PF Motor at correct temperature?	<input type="checkbox"/> Checked			
	<input type="checkbox"/> Not necessary			
	Is the paper path free of any obstructions?	<input type="checkbox"/> Checked		
<input type="checkbox"/> Not necessary				

**Table 4-2. Work Completion Check (continued)**

Classification	Item	Check Point	Status
Adjustment	Specified Adjustment	Are all the adjustment done correctly?	<input type="checkbox"/> Checked
			<input type="checkbox"/> Not necessary
Lubrication	Specified Lubrication	Are all the lubrication made at the specified points?	<input type="checkbox"/> Checked
			<input type="checkbox"/> Not necessary
Function	ROM Version	Version:	<input type="checkbox"/> Checked
			<input type="checkbox"/> Not necessary
Packing	Ink Cartridge	Are the ink cartridges installed correctly?	<input type="checkbox"/> Checked
			<input type="checkbox"/> Not necessary
Others	Attachments, Accessories	Have all the relevant items been included in the package?	<input type="checkbox"/> Checked
			<input type="checkbox"/> Not necessary











### 4.1.4 Screws

The screws used in the printer are as shown in Table 4-3. Make sure you always use the correct type and number of screws for the assembling part. See Table 4-4 for the screw appearances.

**Table 4-3. Screw Specifications**

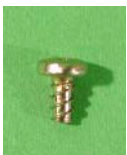
Abbreviation	Description
C.B.P	Cross-recessed Binding Head P-tite screw
C.B.S	Cross-recessed Binding Head S-tite screw
C.P	Cross-recessed Pan Head screw
C.B.(0)	Cross-recessed Binding Head sems B-type screw
C.C	Cross-recessed Cup Head screw

**Table 4-4. List of Screw Types**

No.	Specifications	Appearance	No.	Specifications	Appearance
1	(No.1) C.B.P, M3x10		2	(No.2) C.B.S, M3x6	
3	(No.3) C.B.P, M4x12		4	(No.4) C.B.S, M3x8	
5	(No.5) C.P, M3x14		6	(No.6) C.B.(0), M4x5	
7	(No.7) C.B.P, M3x6		8	(No.8) C.C, M3x4	
9	(No.9) P.F Mount		10	(No.10) C.P, M3x4	
11	(No.11) C.B.P M2.5x5				



## 4.2 Disassembly

The flowchart below shows step-by-step disassembly procedures. When disassembling each unit, refer to the page number shown in the figure.

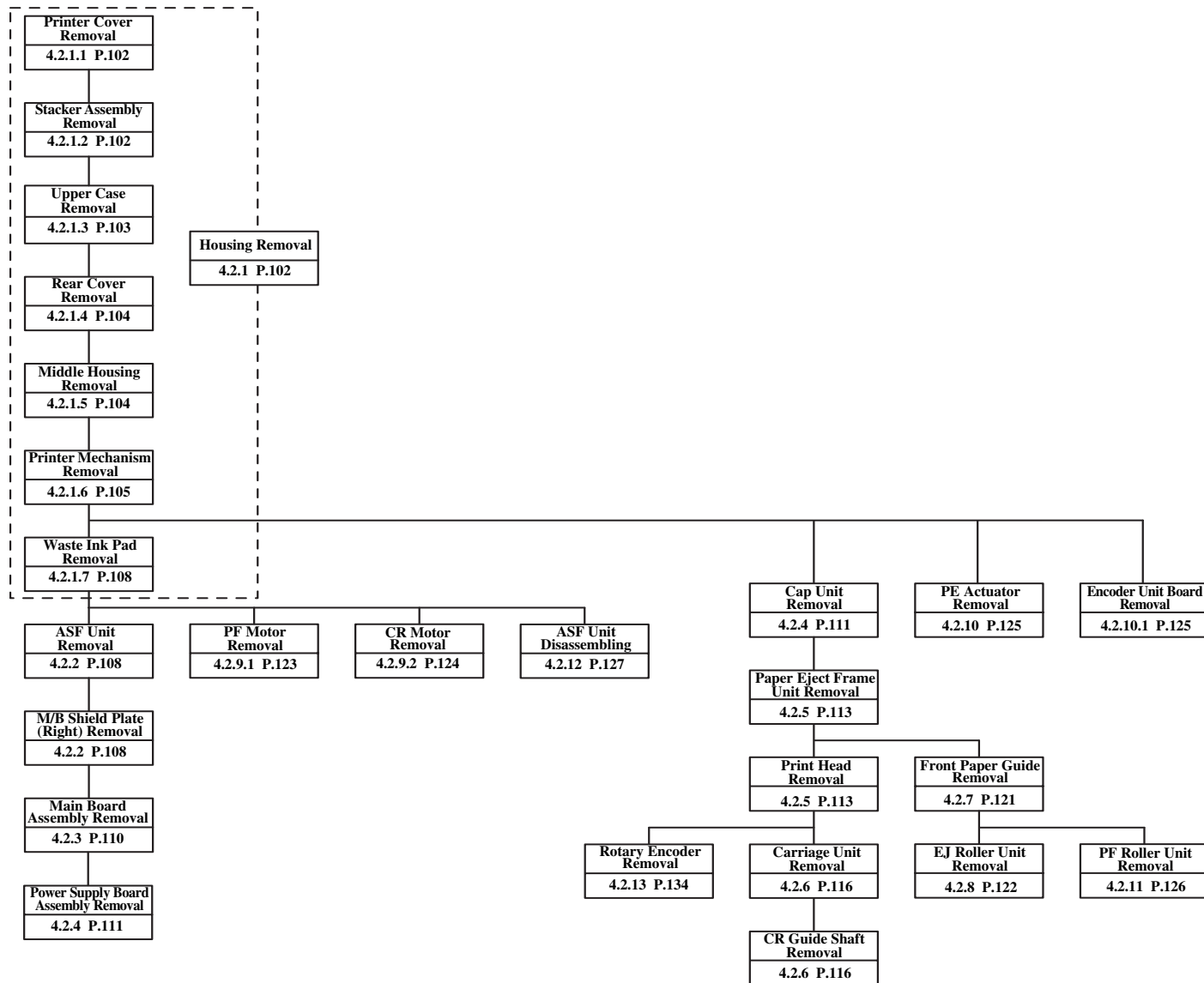

Figure 4-1. Disassembling Flowchart

## 4.2.1 Housing Removal

### 4.2.1.1 Printer Cover Removal

1. Open the Printer Cover.
2. Use a flat-tipped screwdriver or similar tool to disengage the two Hooks, and then remove the Printer Cover.

**CAUTION**

- If you do not use a tool such as a flat-tipped screwdriver to open a gap when removing the printer cover, the hinges may strain and bend. Be careful not to let this happen.
- Be careful not to break the Printer Cover Hooks.

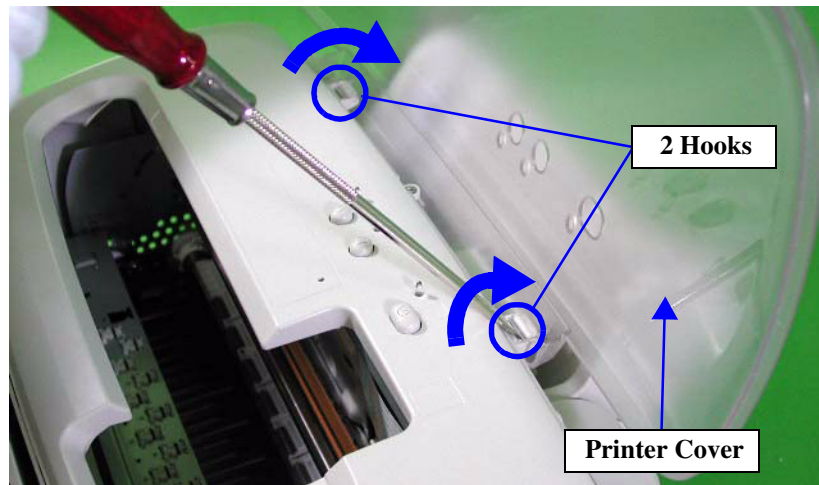

Figure 4-2. Printer Cover Removal

### 4.2.1.2 Stacker Assembly Removal

1. Open the Stacker Assembly.
2. Use a flat-tipped screwdriver or similar tool to disengage the two Hooks, and then remove the Stacker Assembly.

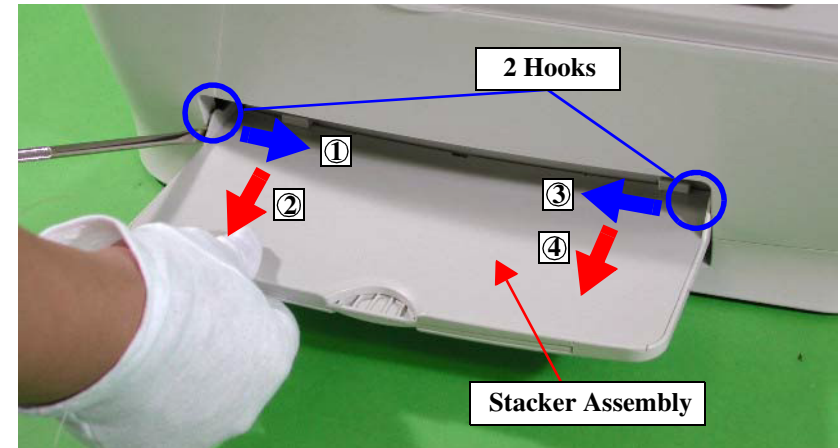

Figure 4-3. Stacker Assembly Removal

### 4.2.1.3 Upper Case Removal

1. Remove the Printer Cover. (Refer to Section 4.2.1.1)
2. Remove the Stacker Assembly. (Refer to Section 4.2.1.2.)
3. Remove the three screws (1) (CBP 3x10 {6±1 kgf.cm}) that are securing the Upper Case.

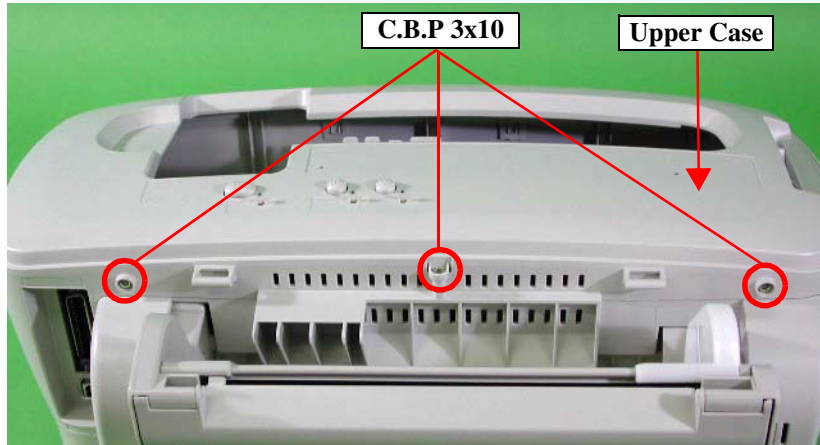

Figure 4-4. Screws Securing the Upper Case

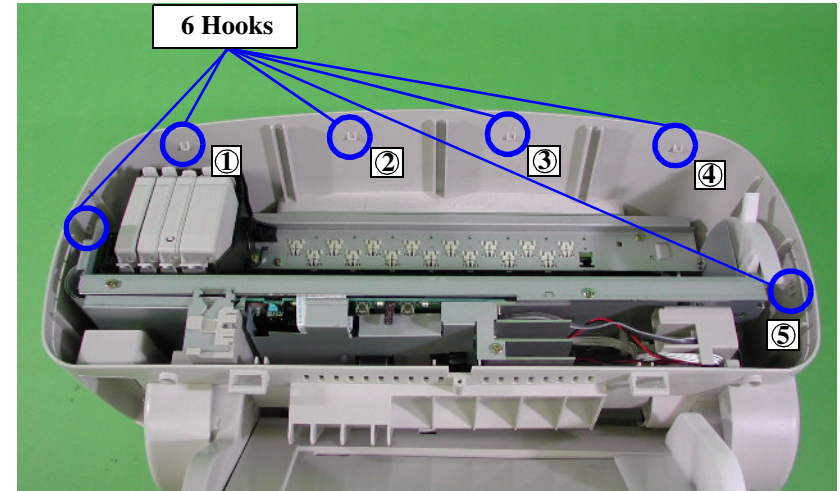

Figure 4-5. Hooks Securing the Upper Case

4. Use tweezers or a flat-tipped screwdriver to disengage the front four Hooks of the six Hooks that are securing the Upper Case, and also the Hook near the PG Lever at the left side of the printer. Then lift up the right side of the Upper Cover while pivoting it on its left side, and remove it from the printer.

**CAUTION**



Be careful not to break the Hook holes.

#### 4.2.1.4 Rear Cover Removal

1. Remove the Upper Case. (Refer to Section 4.2.1.3.)
2. Remove the two screws (1) (CBP 3x10 {6±1 kgf.cm}) and the screw (2) (CBS 3x6 {6±1 kgf.cm}) that are securing the Rear Cover.

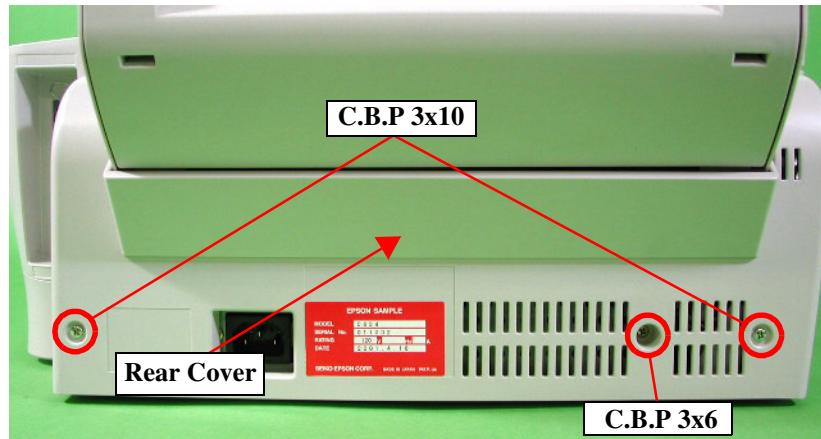

Figure 4-6. Screws Securing the Rear Cover

3. Disengage the two Hooks, and then remove the Rear Cover.

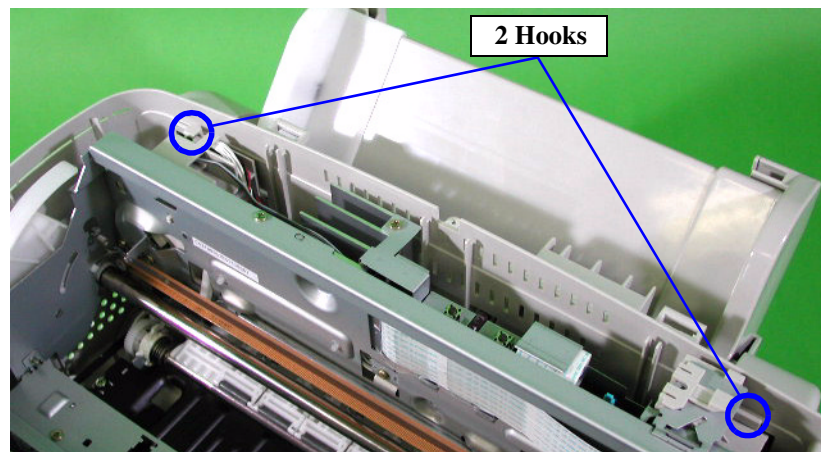

Figure 4-7. Hooks Securing the Rear Cover

#### 4.2.1.5 Middle Housing Removal

1. Remove the Rear Cover. (Refer to Section 4.2.1.4.)
2. Remove the six screws (1) (CBP 3x10 {6±1 kgf.cm}) that are securing the Middle Housing.

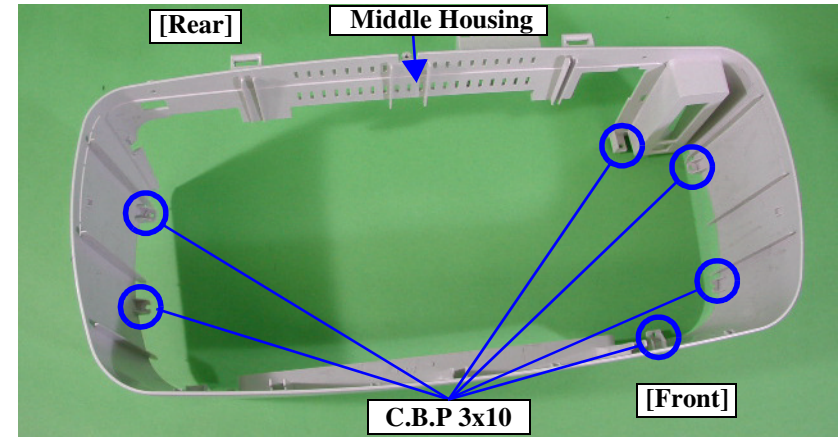

Figure 4-8. Screws Securing the Middle Housing

3. Disengage the Hook, widen the Middle Housing at the front and back slightly while being careful not to pull the I/F clamps and the USB connector, and then remove the Middle Housing.

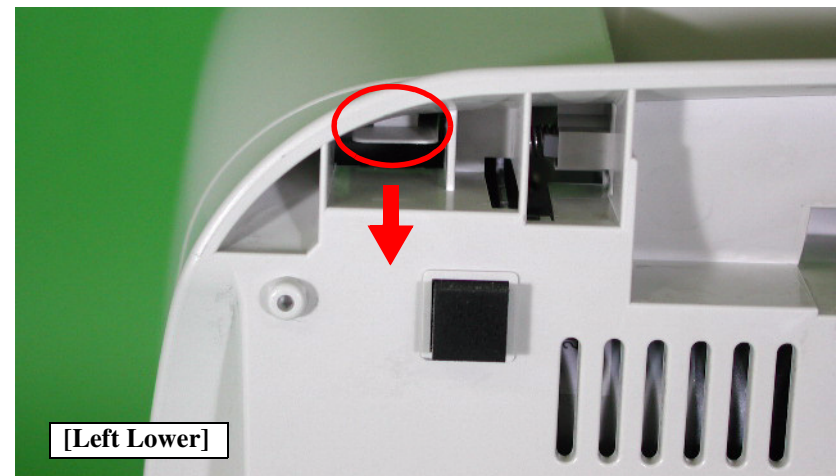

Figure 4-9. Hooks Securing the Middle Housing



**CHECK  
POINT**

Use a flat-tipped screwdriver or your finger to disengage the Hook from the notch at the bottom of the Lower Case.

**CAUTION**

- When removing the Middle Housing, be careful no to let the screw fixing lip at the left of the printer come into contact with the PG Lever Tension Spring and cause it to fly off.
- Be careful not to break the Middle Housing Hook Holes.

**4.2.1.6 Printer Mechanism Unit Removal**

1. Remove the Middle Housing. (Refer to Section 4.2.1.5.)
2. Remove the screw (2) (CBS 3x6) and the two screws (3) (CBS 4x12 {6±1 kgf.cm}) that are securing the Lower Case.

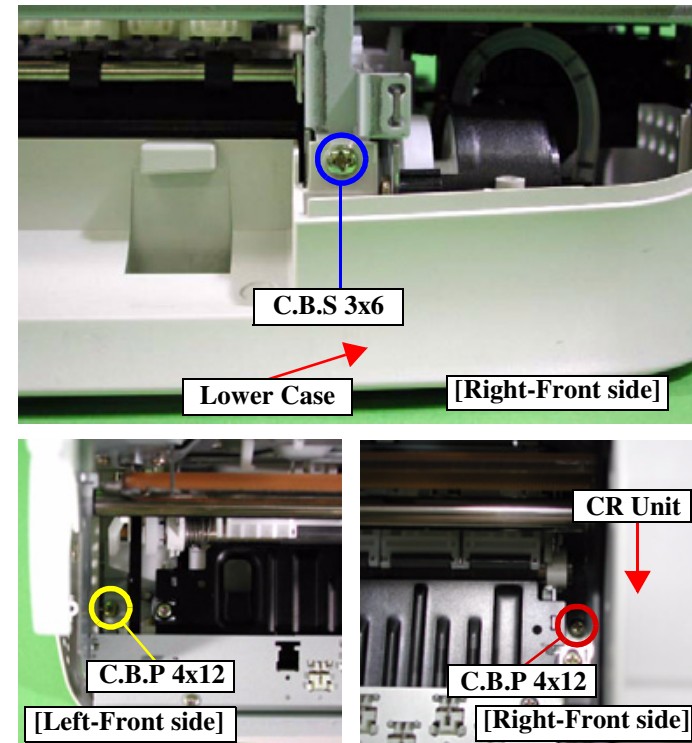

Figure 4-10. Screws Securing the Lower Case

3. Disengage the two Hooks, and then remove the Lower Case.

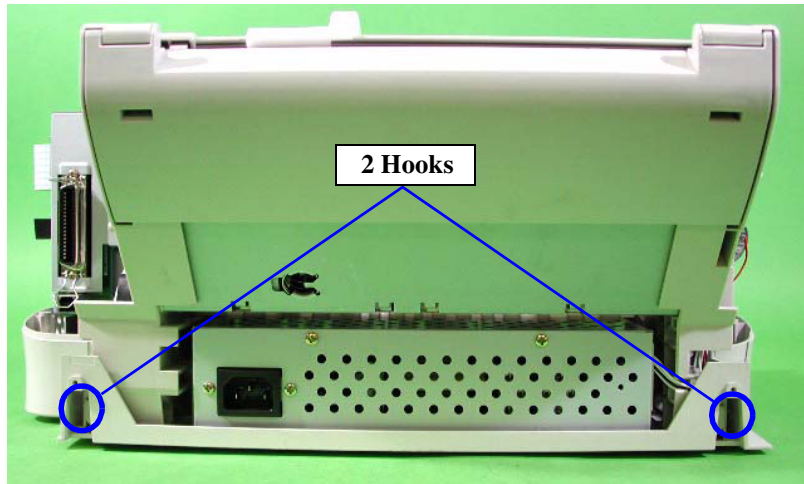

Figure 4-11. Hooks Securing the Lower Case (1)

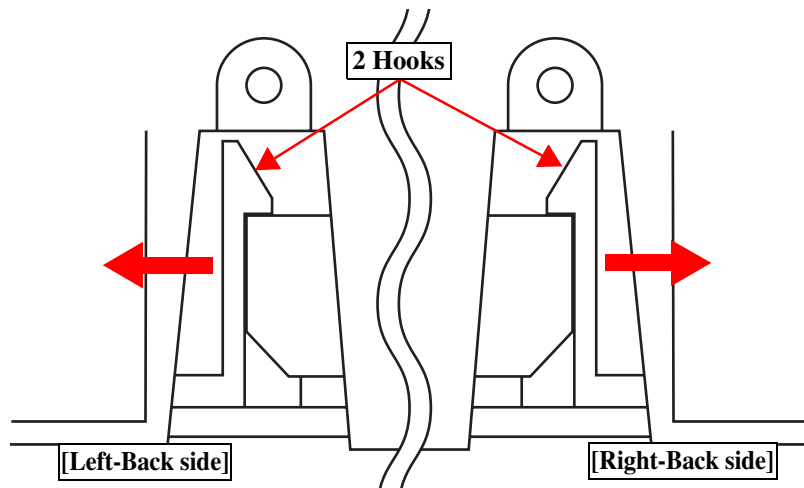

Figure 4-12. Hooks Securing the Lower Case (2)



When you install the printer mechanism on to Lower Housing, locate a ink tube top to the correct position on its pad. If you forget this, user will encounter the ink leak trouble.

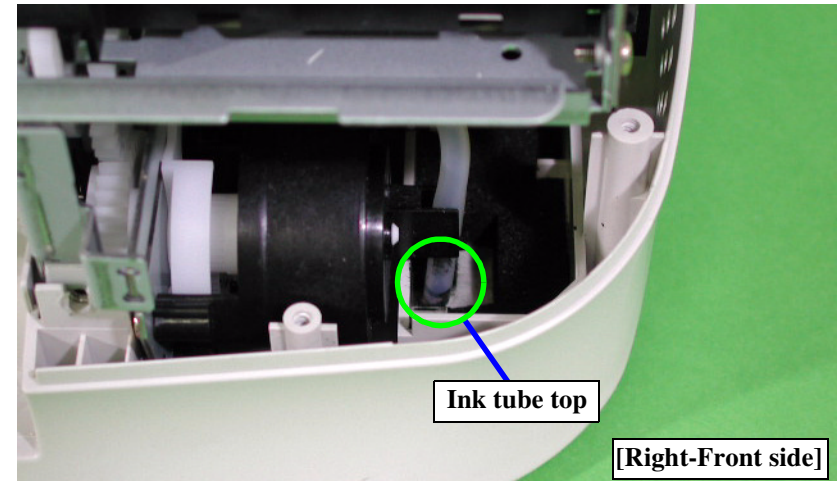

Figure 4-13. Ink Tube Top Position



- In the same way as with previous models, the Print Head and Cleaner Blade are not pre-installed when the Printer Mechanism is being replaced. However, there are restrictions in the way the Cleaner Blade is installed which are different from previous models, so the following should always be observed at this time.
  - If you replace to new waste ink drain pad, be sure to dear the current protection counter by using adjustment program. (Refer to chap. 5)
4. Turn the Pinion Gear on the PF Motor to operate the Ink System so that the Cleaner Blade can be checked. The Cleaner Blade must not touch any of the Gears around the PF Motor at this time.



These Gears (Spur Gear 21.5, Combination Gears 10.5 and 21.2, Combination Gear 12x16 and Spur Gear 21: see the photograph below for details) are high-precision Gears. The precision settings for these Gears can change as a result of oil from operators' hands or as the result of impacts, and so particular care must be taken with regard to them. Accordingly, when moving the Cleaner Blade to the active position, do not touch these gears by hand. Instead, turn the Pinion Gear on the PF Motor in order to carry out the check.

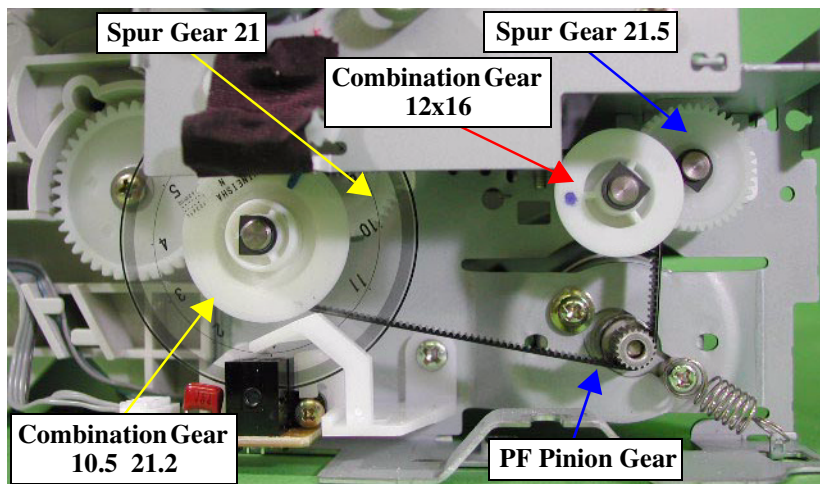

Figure 4-14. Cleaner Blade Installation (1)

- Use tweezers to place the Cleaner Blade into the Cleaner Lever. At this time, always check which end is the Rubber end and which end is the Cloth end, and be sure to set the blade so that it faces in the correct way. The correct setting method for the Cleaner Blade is shown below.

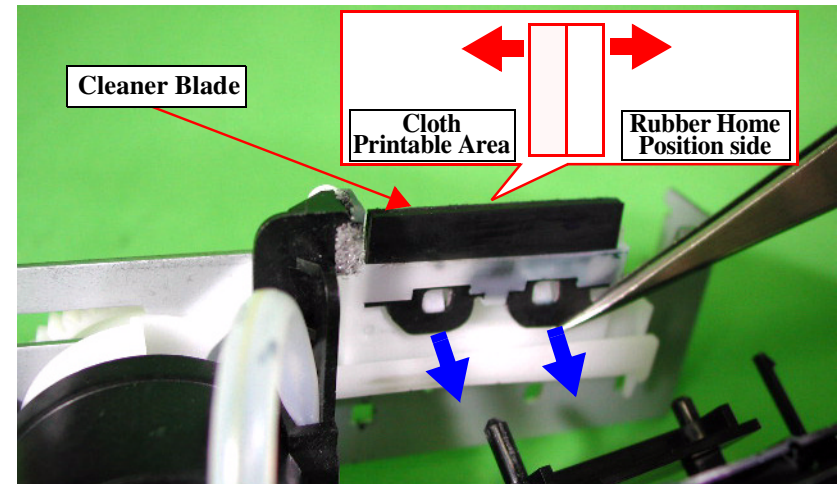

Figure 4-15. Cleaner Blade Installation (2)

### 4.2.1.7 Waste Ink Pad Removal

1. Remove the Printer Mechanism. (Refer to Section 4.2.1.6)
2. Remove the two Waste Ink Pad from Lower Case.

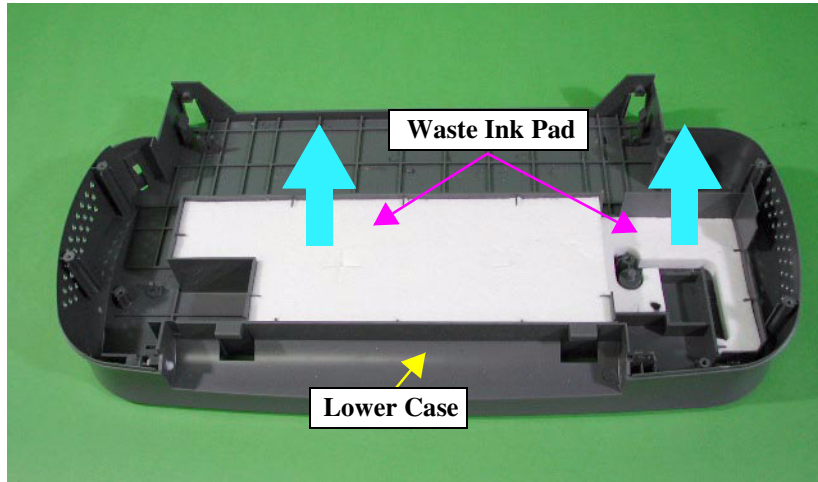

Figure 4-16. Waste Ink Pad Removal

### 4.2.2 ASF Unit Removal

1. Remove the Printer Mechanism. (Refer to Sections 4.2.1.6.)
2. Remove the two screws (4) (CBS 3x8 { $8\pm 1$  kgf.cm}) that are securing the ASF Unit.

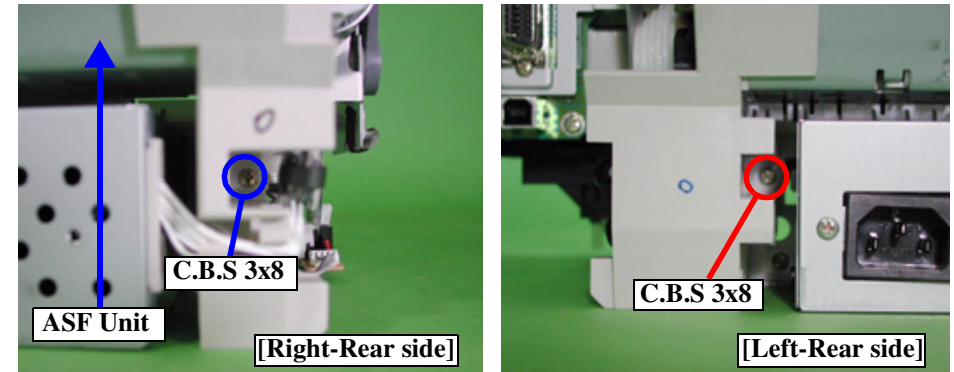

Figure 4-17. Screws Securing the ASF Unit

3. Remove the screw (2) (CBS 3x6 { $8\pm 1$  kgf.cm}) that is securing the LD Roller Cover, and then slide the LD Roller Cover to the left.

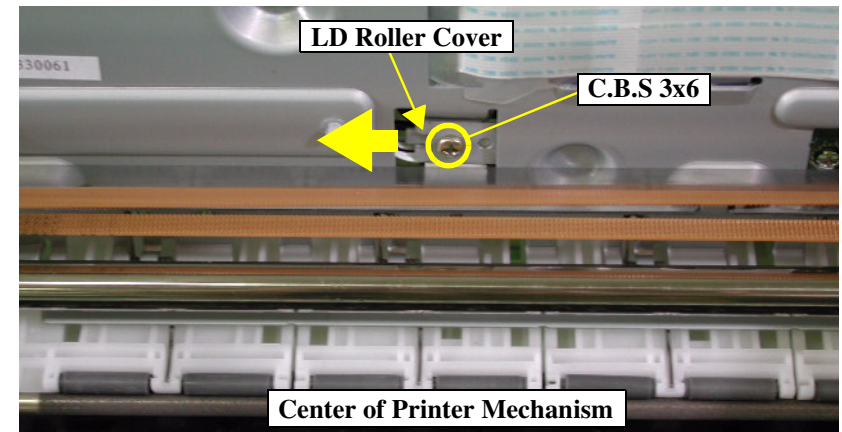

Figure 4-18. Screw Securing the LD Roller Cover

4. Disengage the Hook, and then turn the ASF Mounting Plate to the right to remove it.



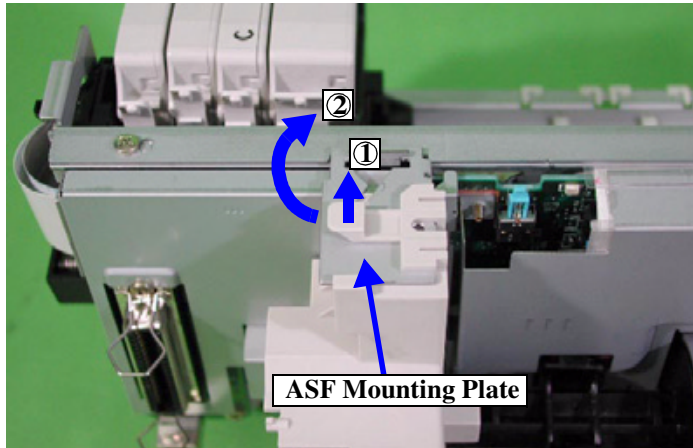

Figure 4-19. ASF Mounting Plate Removal

5. Disconnect the connector (white 4-pin) from the Encoder Board Assembly.
6. Remove the screw (4) (CBS 3x8 { $8\pm 1$  kgf.cm}) and the screw (2) (CBS 3x6 { $8\pm 1$  kgf.cm}) that are securing the two Shield Plates to the Main Board Assembly (one of the screws is securing two plates). Then remove the Shield Plate (Right).

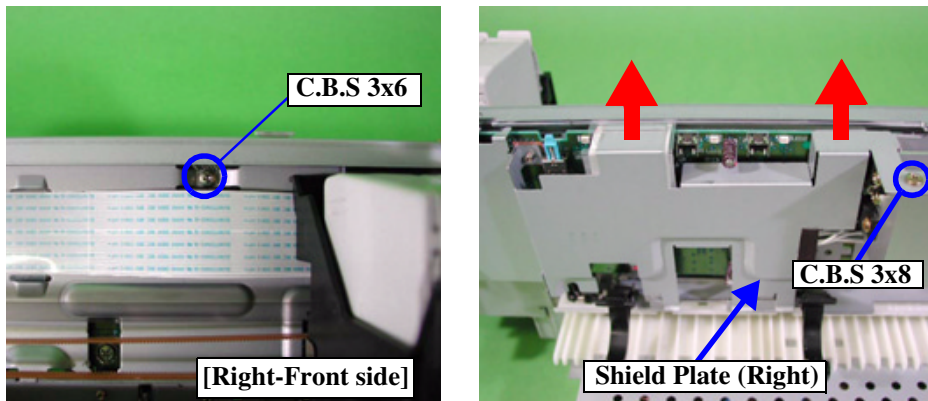

Figure 4-20. Shield Plate (Right) Removal

7. Disconnect the four connectors (CN12: white 4-pin, CN13: black 2-pin, CN14: white 2-pin and CN15: white 8-pin) from the Man Board Assembly.

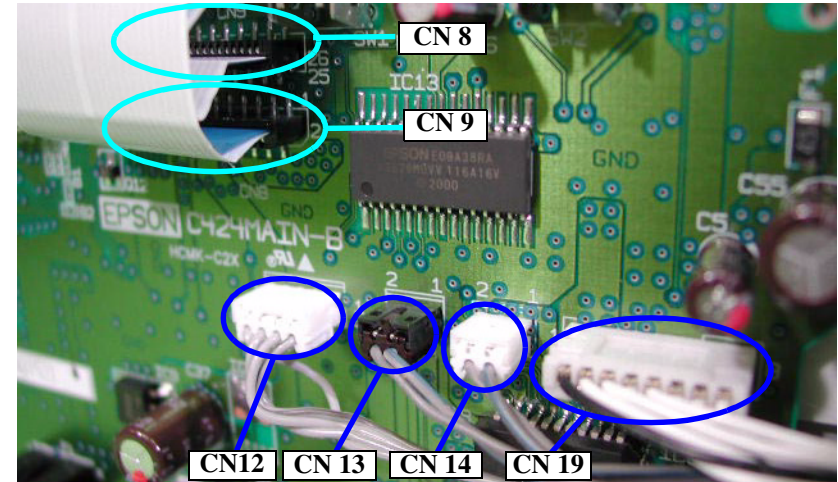

Figure 4-21. Connectors Removal

8. Remove all Harnesses from the Harness Slots in the Left ASF Frame.

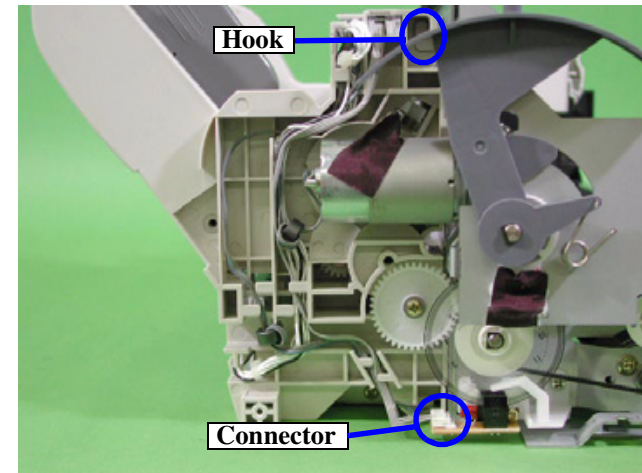

Figure 4-22. Harness Removal



- When re-installing the ASF Unit, make sure that all Harnesses are placed into the appropriate slots while referring to Figure 4-22.
- When installing the ASF Unit to the Printer Mechanism, it should be installed so that the Left ASF Frame is in the correct position.
- When installing the ASF Unit, the Change Lever inside the ASF Unit will protrude from the mechanism, so move the Change Lever to the outside while installing the ASF Unit to the Printer Mechanism.

9. Remove the ASF Unit by pulling it out from the Rear.



After removing the ASF Unit, two positioning dowels for use when installing the ASF Unit to the mechanism can be seen on each of the ASF Unit Frames. When re-installing the ASF Unit, these four dowels should be positioned so that they fit into the notches in the Printer Mechanism in order to make installation easier.

### 4.2.3 Main Board Assembly Removal

1. Remove the ASF Unit. (Refer to Section 4.2.2.)
2. Remove the two screws (5) (CP 3x14 {8±1 kgf.cm}) that are securing the M/B Shield Plate, and then remove the M/B Shield Plate.

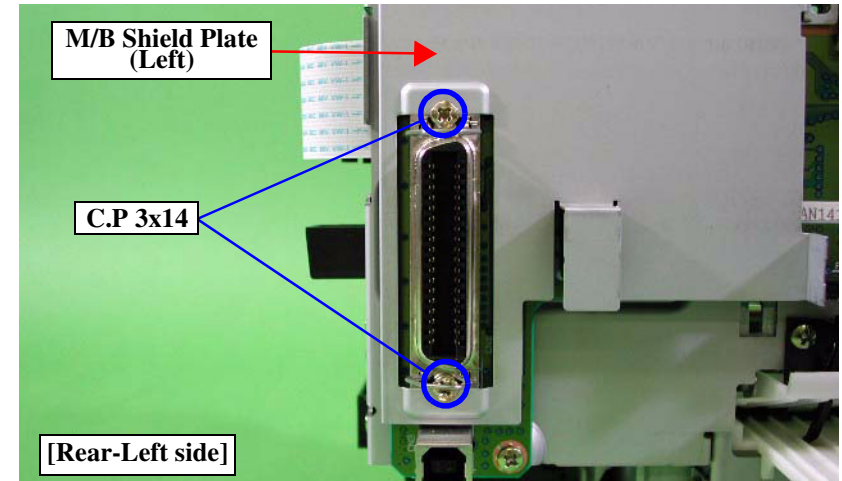

Figure 4-23. Screws Securing the M/B Shield Plate

3. Disconnect the FFC Cables (CN8 and CN9) from the Main Board Assembly.



When reconnecting the FFCs, the one with the blue film at the bottom connects to CN9, and the one with the blue film at the top connects to CN8.

4. Remove the three screws (2) (CBS 3x6 {8±1 kgf.cm}) that are securing the Main Board Assembly.

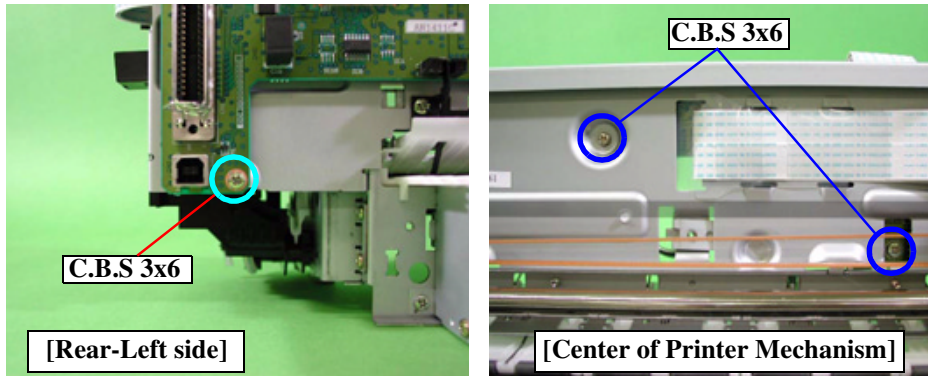

Figure 4-24. Screws Securing the Main Board Assembly

- Slide the Main Board Assembly upward to remove it.

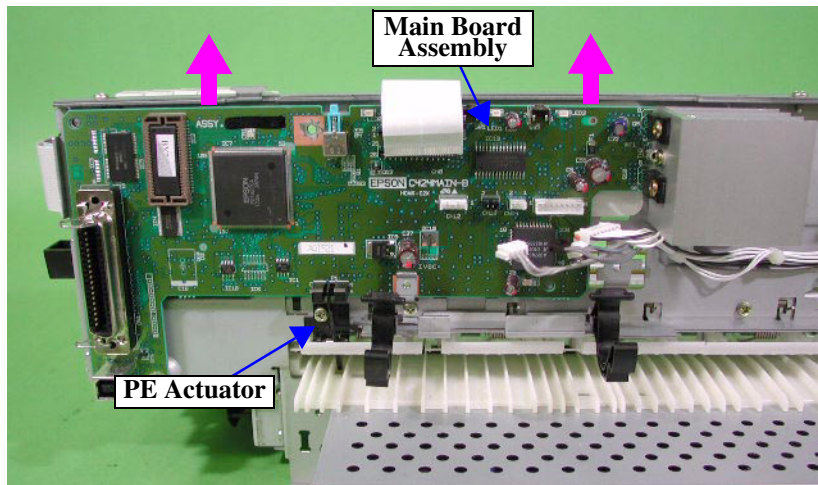

Figure 4-25. Main Board Assembly



When the Main Board Assembly has been replaced, all circuit board settings will be returned to their default setting values, so the following adjustments should be carried out. For details, refer to Table 5-1 in Chapter 5.

#### 4.2.4 Power Supply Board Assembly Removal

- Remove the ASF Unit. (Refer to Section 4.2.2.)
- Remove the four screws (2) (CBS 3x6 {8±1 kgf.cm}) that are securing the P/S Lower Shield Plate Unit, and then remove the P/S Board Assembly together with the P/S Lower Shield Plate Unit.

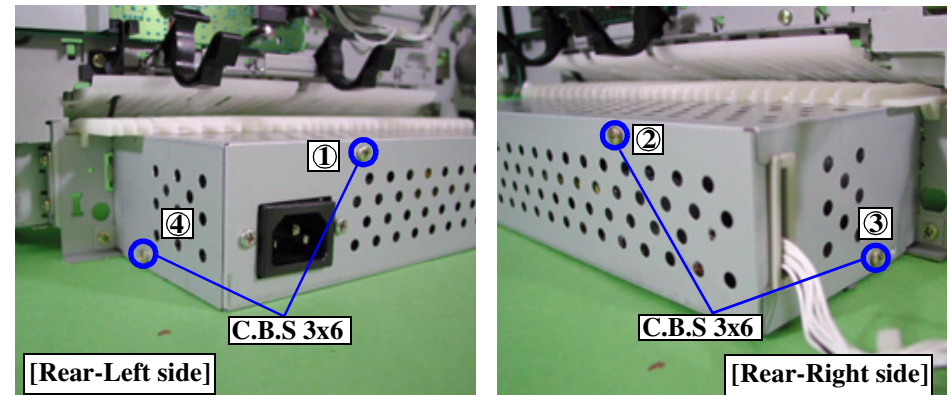

Figure 4-26. Screws Securing the P/S Lower Shield Unit

- Remove the two screws (2) (CBS 3x6 {8±1 kgf.cm}) and the screw (6) (CB (0) 4x5 11±1 kgf.cm}) that are securing the AC Inlet Mounting Plate.

**CAUTION**



When lifting up Re-installing the Main Board Assembly, be careful not to remove the PE Detector and Actuator.



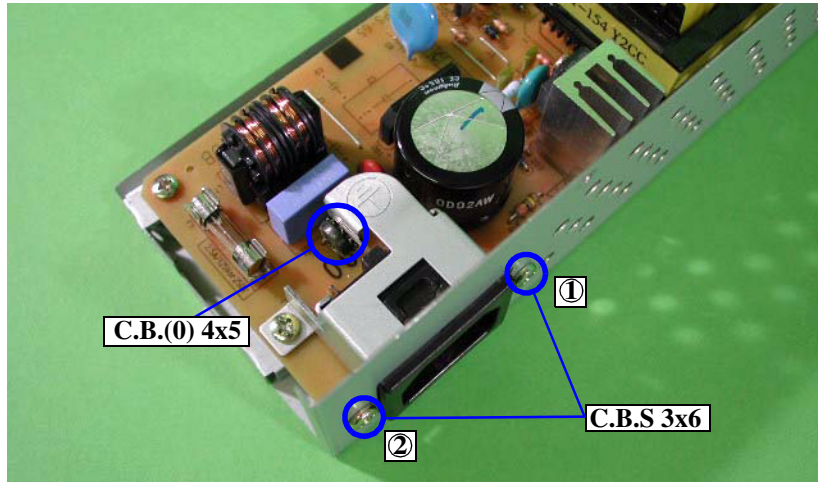

Figure 4-27. Screws Securing the AC Inlet Mounting Plate

4. Remove the five screws (2) (CBS 3x6 {6±1 kgf.cm}) that are securing the Power Supply Board Assembly.

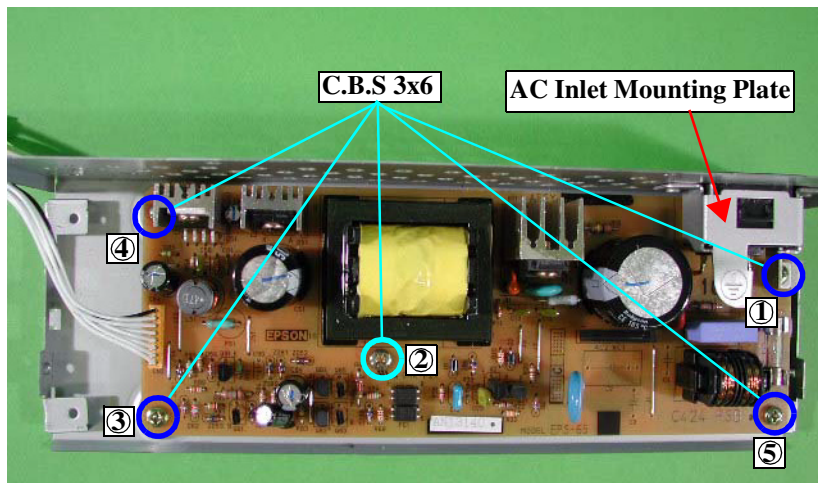

Figure 4-28. Screws Securing the Power Supply Board

5. Remove the AC Inlet Mounting Plate and then the Power Supply Board Assembly in that order.



- When installing the power supply board assembly and the AC inlet mounting plate, the screws should be installed in the order shown in the illustration. (Figure 4-27, 4-28)
- When installing the Cable Cover, it should be installed so that the side with the notches is facing upward.

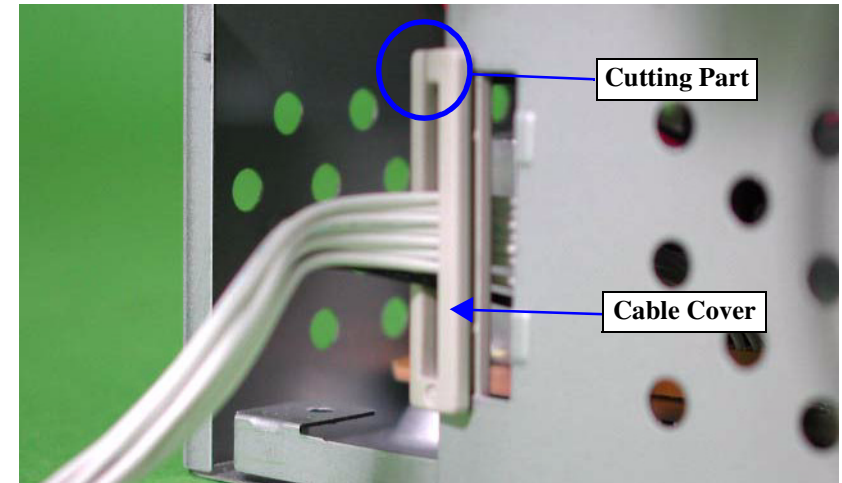

Figure 4-29. Cable Cover Installation

- When installing the P/S Lower Plate Unit, the screws should be installed in the order shown in the illustration. (Figure 4-26)

### 4.2.5 Print Head / Ink System Unit Removal

1. Remove the Printer Mechanism. (Refer to Sections 4.2.1.6.)
2. Remove the Ink Cartridges.
3. Release the CR Lock Lever.

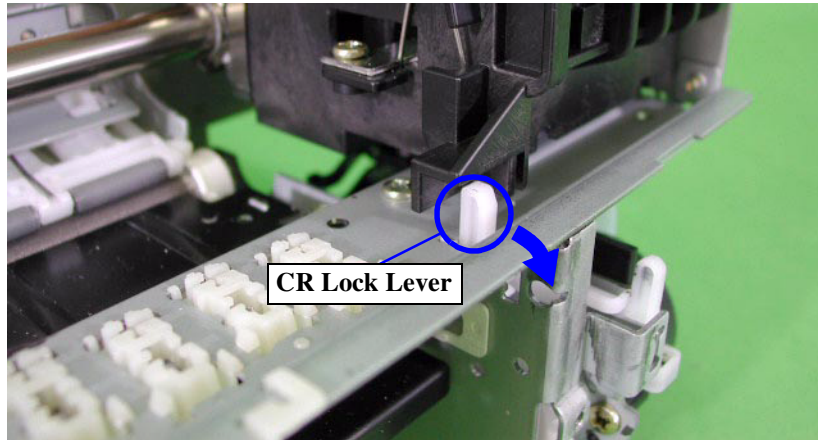

Figure 4-30. CR Lock Lever Releasing

4. Remove the ASF Mounting Plate. (Refer to Step 4 of Section 4.2.2.)
5. Move the Carriage Unit manually to the middle position.



If the Carriage Unit is moved to the middle position after removing the CR Guide Plate instead of at this time, the Head will contact the Front Paper Guide while the Carriage Unit is being moved and this will damage the Head.

6. Remove the two screws (2)(CBS 3x6 {8±1 kgf.cm}) that are securing the CR Guide Plate, and then remove the CR Guide Plate.

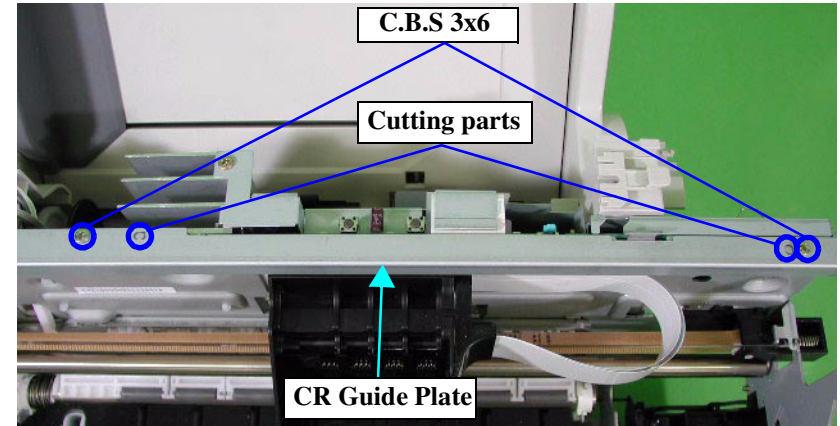

Figure 4-31. CR Guide Plate Removal



When installing the CR Guide Plate, fit the two dowels into the two holes.

7. Disengage the four Hooks, and then remove the Cable Head Holder.

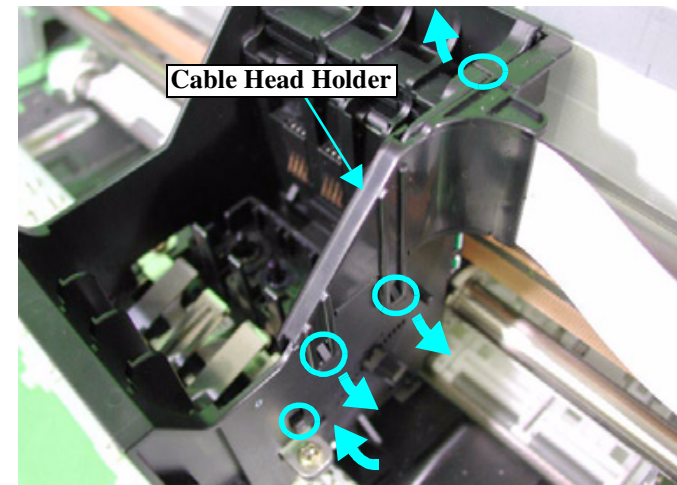

Figure 4-32. Cable Head Holder Removal



**CAUTION**



Be careful not to break the Cable Head Holder Hook.

- Remove the five screws (2) (CBS 3x6 {8±1 kgf.cm}) that are securing the Cap Unit and Pump Unit to the Printer Mechanism, and then remove the Cap Unit and Pump Unit together with the Bracket.

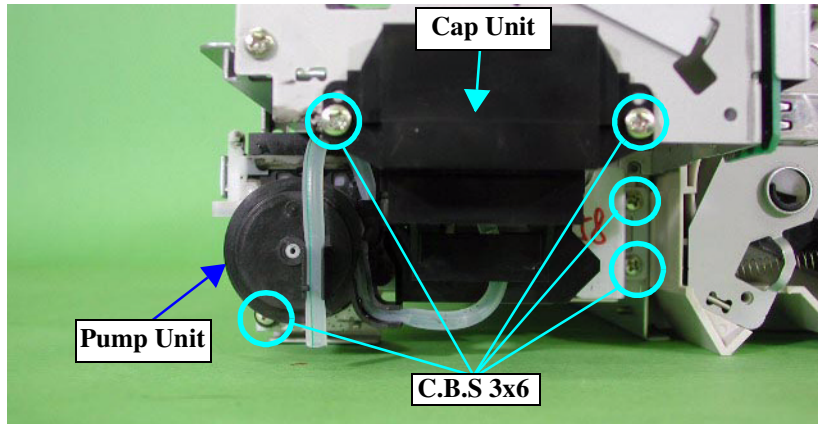

Figure 4-33. Cap Unit and Pump Unit Removal

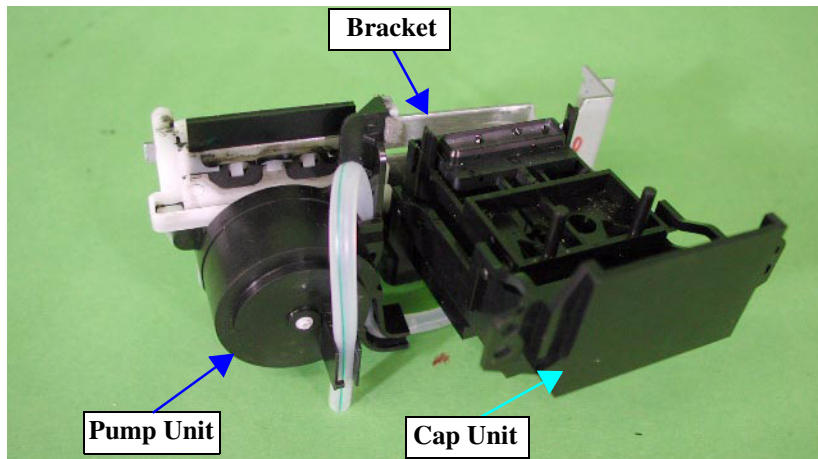

Figure 4-34. Cap Unit and Pump Unit

- Remove the four screws (2) (CBS 3x6 {8±1 kgf.cm}) that are securing the Paper Eject Frame Unit to the Printer Mechanism, and then remove the Paper Eject Frame Unit.

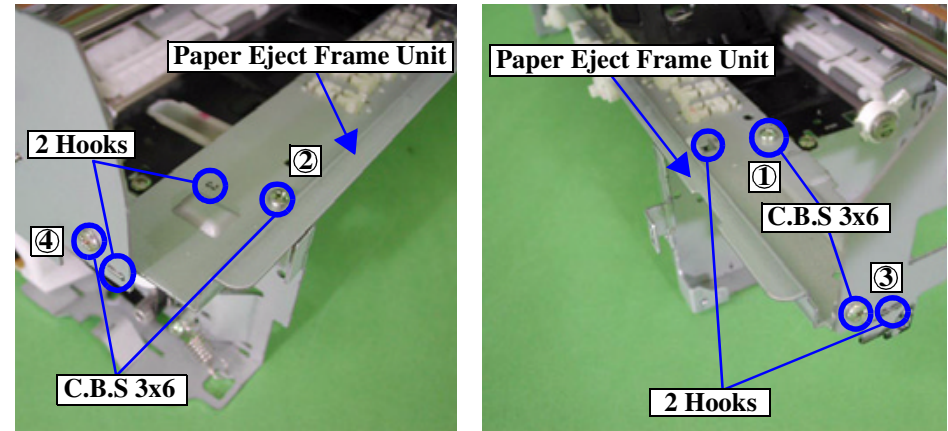

Figure 4-35. Paper Eject Frame Unit Removal



- When installing the Paper Eject Frame Unit install the screws in the order shown in the illustration.
- When installing the Paper Eject Frame Unit, insert the four Hooks securely
- Secure the CR Lock Lever so that it is out of the notch.

- While tilting up the Carriage Unit as if to remove it, move it to the home position.

**CAUTION**



If the Carriage Unit is moved without taking proper care, the end of the Head on top of the Front Paper Guide will hit the Carriage Unit and may cause unnecessary damage to the Head, so take proper care when moving the Carriage Unit.

- Remove Torsion Spring 49.
- Remove the two screws (7) (CBP 3x6 {6±1 kgf.cm}) that are securing the Sus-Plate 2.

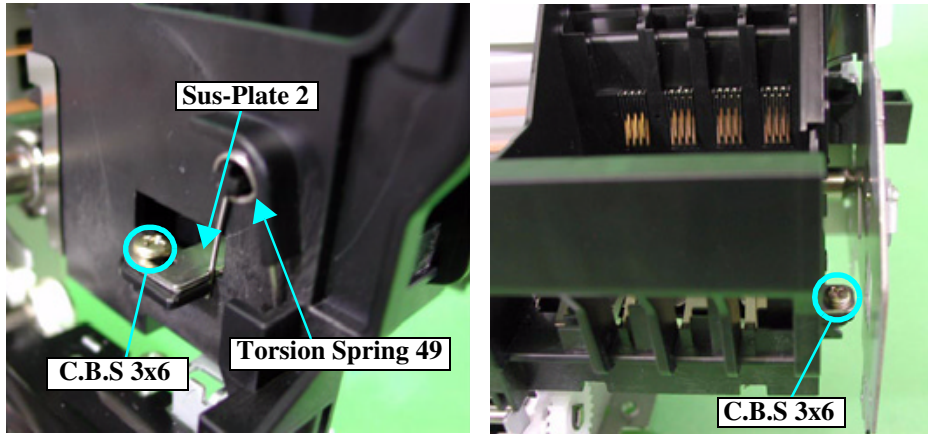

Figure 4-36. Screws Securing the Sus-Plate 2

13. One by one, slide up one side of Sus-Plate 1 and Sus-Plate 2 that are applying tension to the Ink Cartridge, and then remove Sus-Plate 1 and Sus-Plate in that order.

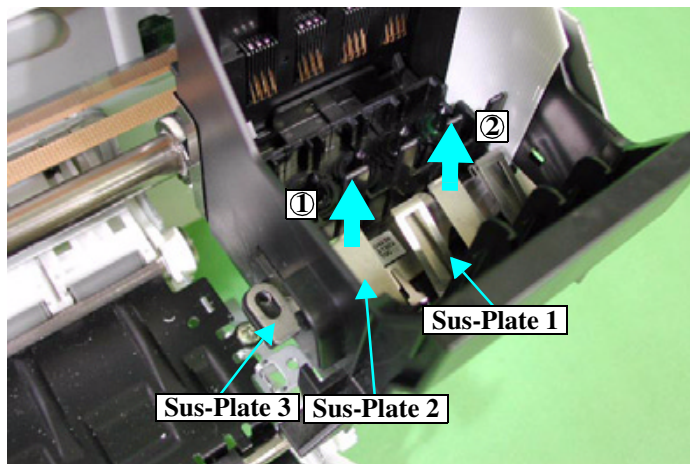

Figure 4-37. Sus-Plate 1, Sus-Plate 2 Removal

14. Remove Sus-Plate 3. Sus-Plate 3 can only be removed from the left side. Furthermore, it should also be inserted from the left side when it is installed.

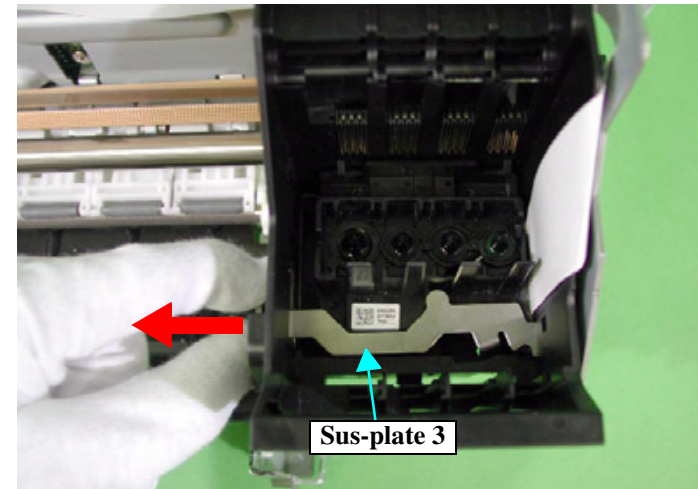

Figure 4-38. Sus-Plate 3 Removal

15. To avoid the two projections which are pressing down on the Print Head from above, slide the Print Head unit forward slightly, and then lift the Print Head up.

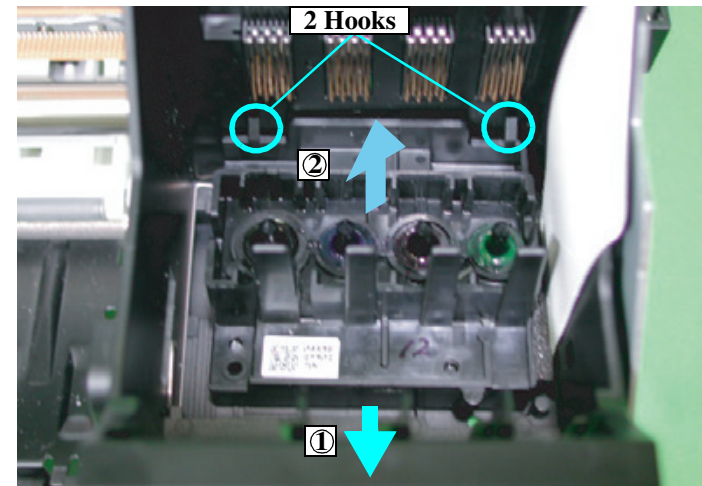

Figure 4-39. Print Head Moving

16. Disconnect the two FFCs, and then remove the Print Head.

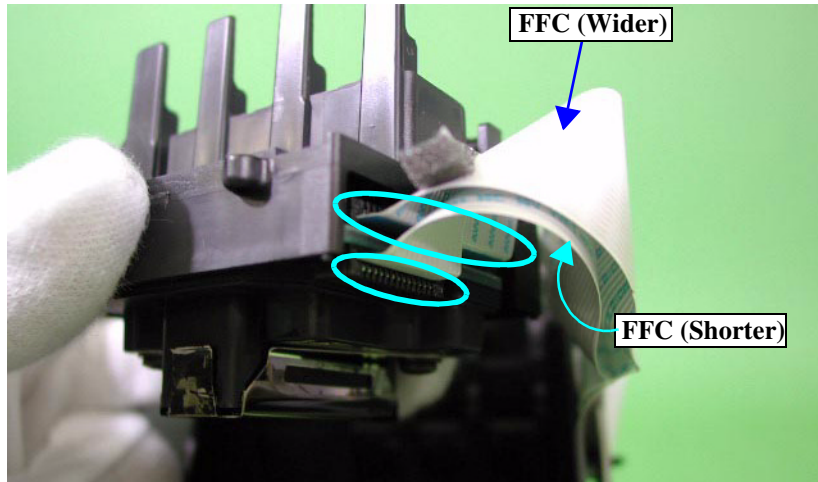

Figure 4-40. Print Head Removal

## 4.2.6 Carriage Unit / CR Guide Shaft Removal

1. Remove the Print Head. (Refer to Section 4.2.5.)



Various adjustments must be carried out after removing or replacing the Print Head.  
Be sure to carry out these adjustments in the order given Table 5-1 in chapter 5.



When replacing or re-installing the Print Head, make sure that the CR Guide Plate is correctly installed first.  
If this is not done, the end of the Print Head may contact the surface of the Paper Guide, which could cause damage to the Print Head during installation.

2. Remove the Extension Spring 1.494 which is securing the left side of the Linear Scale from the top of the Main Frame (Left).



When removing the Extension Spring 1.494, handle the spring carefully and do not pull it more than necessary, otherwise the spring may become stretched.



The Extension Spring 1.494 will not fall down even when it is removed from the Main Frame (Left).

3. Disengage the right side of the Linear Scale which is secured to the Mechanism Frame.  
4. Disengage the left side of the Linear Scale which is secured to the Mechanism Frame.  
5. Pull out the Linear Scale from the left side.



- When removing or re-installing the Print Head, do not touch the surfaces of the nozzles against the Carriage Unit.
- When reinstalling the FFC cable, make sure that it is correctly and securely connected, otherwise head short-circuits or main circuit board transistor short-circuits may occur.



Various adjustments must be carried out after removing or replacing the Print Head.  
Be sure to carry out these adjustments in the order given Table 5-1 in chapter 5.



When replacing or re-installing the Print Head, make sure that the CR Guide Plate is correctly installed first.  
If this is not done, the end of the Print Head may contact the surface of the Paper Guide, which could cause damage to the Print Head during installation.



**CAUTION**



If the Linear Scale is pulled out from the right side, the Extension Spring 1.494 may be damaged, so always pull it out from the left side.

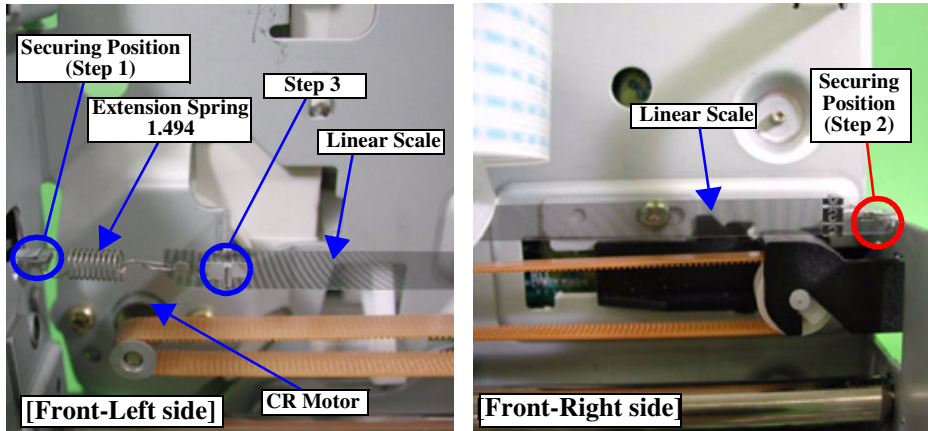

Figure 4-41. Liner Scale Removal

**REASSEMBLY**



When installing the Extension Spring to the Liner Scale, be careful not to twist the end of the Spring.

6. Carefully peel off the double-sided tape on the FFC, and disconnect the FFC from the Rear of the Carriage Unit.
7. Disconnect the FFC from the connector on the Print Head Control Board at the rear of the Carriage Unit.

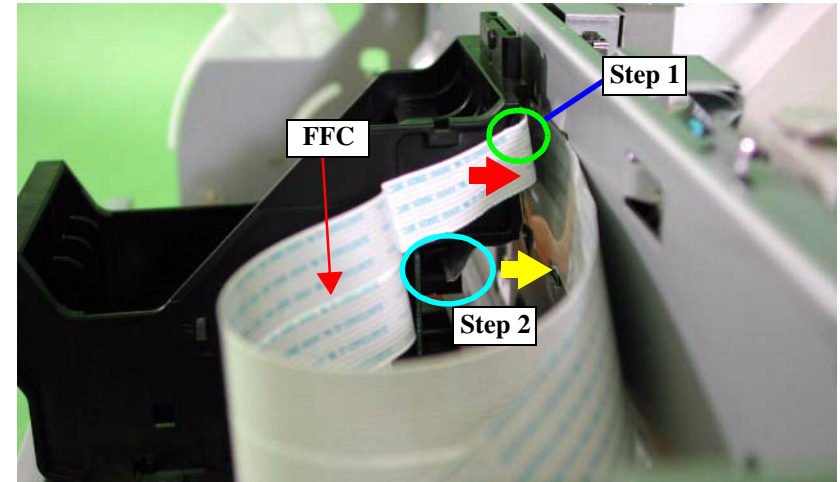

Figure 4-42. FFCs Removal

**WARNING**



When the Carriage Unit has been completely removed and is being re-installed, make sure that you first connect the FFC to the connector on the Print Head Control Board at the Rear of the Carriage Unit. Then install the Guide Shaft to the Carriage Unit and secure it to the Printer Mechanism. If you try to connect the FFC after the CR and the CR Shaft have been installed, it will not be possible to insert it correctly; and if it is inserted at an angle, damage to the Head Shaft may occur.

- Remove the Timing Belt from the Pinion Gear on the CR Motor.

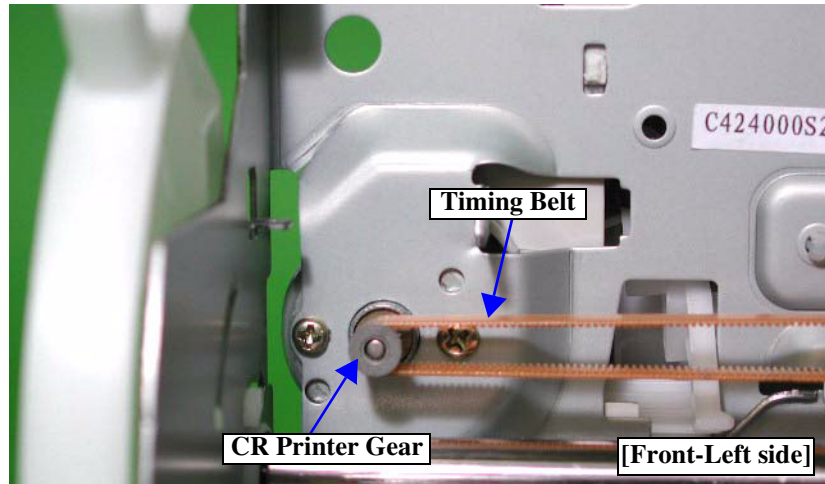

Figure 4-43. Timing Belt Removal

- Use tweezers or similar to lift up and remove the compressed spring inside the Pulley Driven Holder.

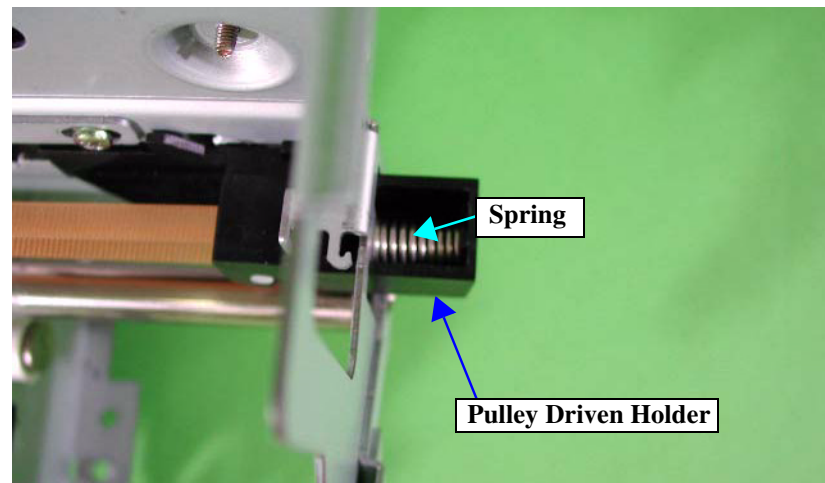

Figure 4-44. Spring Removal

- Remove the screw (2) (CBS 3x6 {8±1 kgf.cm}), and then remove the Holder Stopper.



When re-installing the Holder Stopper, secure it so that there is a clearance of 2–5 mm between it and the Pulley driven holder.

- The Pulley Driven Holder should be moved approximately 10 mm to the left. Remove the Pulley Driven Holder Unit so that the entire Pulley Driven Holder Unit can be removed from the frame.

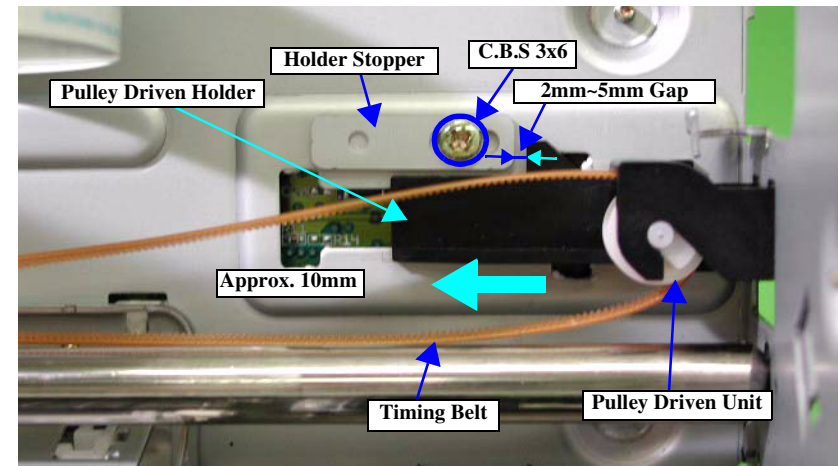

Figure 4-45. Pulley Driven Holder Removal



- If the intention is to remove the Carriage Unit as a single block, there is no need to remove the Pulley Driven Holder Unit from the Pulley Driven Holder. However, if CR Guide Shaft and Carriage Unit are being replaced because the Page Counter or Protection Counter is showing its maximum serviceable limit value or over, it is recommended that the Pulley Driven Unit (which is a consumable part) is also removed from the Pulley Driven Holder at this time. When installing the CR Guide Shaft to the Carriage Unit, the Oil Pad should be installed to the base at the rear of the Carriage Unit.
- This product has a page counter, but there is no upper limit, so no upper limit errors can occur. The function is provided as reference.

12. Remove the Spacer that are securing the PG Lever.
13. First remove torsion spring 141.1, and then pull the PG lever to the left to remove it. At this time, it is easier to remove torsion spring 141.1 if the PG lever is moved to the + side (rear).

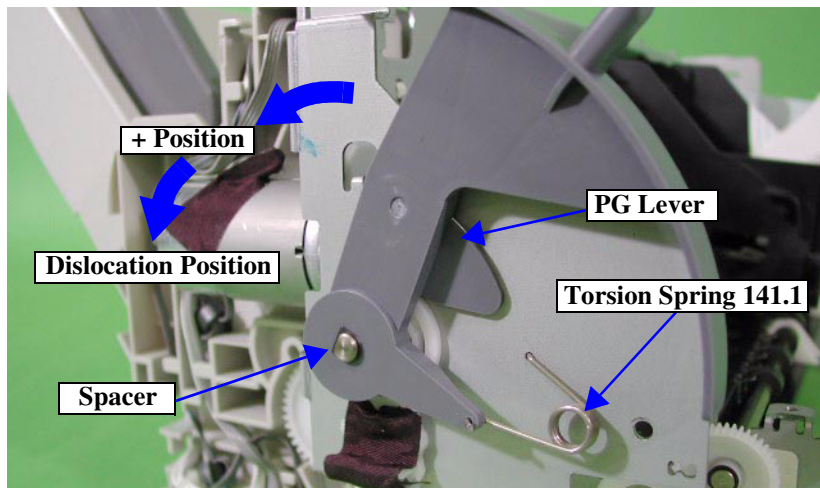

Figure 4-46. Torsion Spring 141.1 and PG Lever Removal

14. Remove the screw (2) (CBS 3x6 {8±1 kgf.cm}) with washer that is securing the PG adjust bushing in position.

15. While pulling the PG Adjust Lever forward, turn it counterclockwise to disengage it. Once it has been disengaged, remove the PG Adjust Lever.

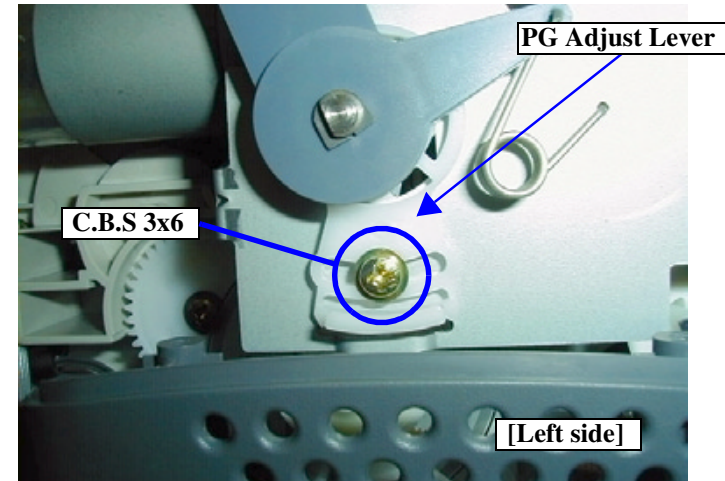

Figure 4-47. PG Adjust Lever Removal

16. Lower the PG Adjust Lever Support Plate together with the CR Guide Shaft to disengage from the Hook, and then slide the PG Adjust Lever Support Plate forward to remove it.

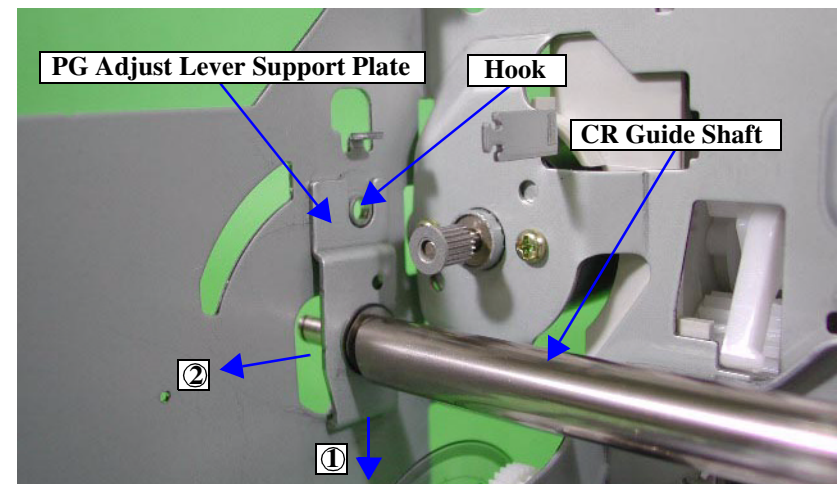

Figure 4-48. PG Adjust Lever Support Plate Removal



17. Pull the CR Guide Shaft out from the left. At this time, be careful not to lose the three washers (Leaf Washer and two Normal Washer) which are inserted into the left side of the CR Guide Shaft.

Also, be careful not to lose the leaf-spring on the right edge of the carriage guide shaft.

**CAUTION**

After the CR Guide Shaft has been removed, make sure that it is handled carefully. Furthermore, when removing it from the Printer Mechanism, make sure that the surface of the CR Guide Shaft does not touch any of the notches. If you try to re-use the CR Guide Shaft once it has been damaged, the friction between it and the Carriage Unit will increase and unexpected CR errors may occur.

**CHECK POINT**

- When installing Torsion Spring 141.1, the U-shaped end should be installed to the PG Lever.
- When installing the CR Guide Shaft to the CR Frame, the D-cut end of the Shaft should be at the left.
- Install the Leaf Spring, Plain Spring and PG Lever to the CR Guide Shaft in that order.
- The Leaf Spring should be installed so that the arch-shaped section is on the outside.
- When installing the CR Guide Shaft to the Carriage Unit, the Oil Pad should be installed to the base at the rear of the Carriage Unit.
- When replacing the oil pad, refer to Chapter 6 for details on correct lubrication. Adding oil is strictly prohibited.

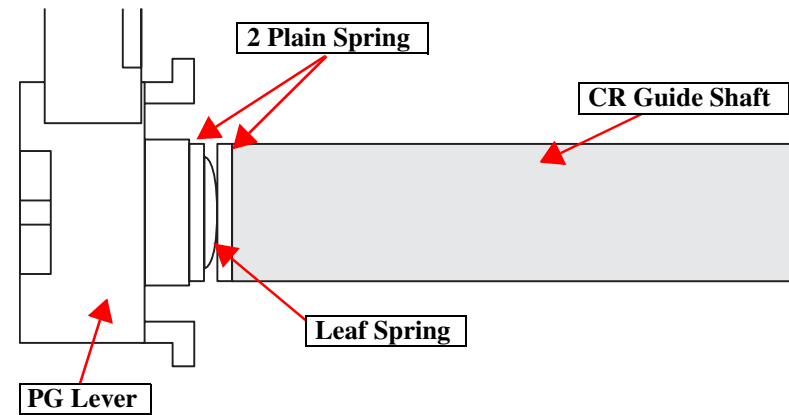

Figure 4-49. CR Guide Shaft Installation Sequence

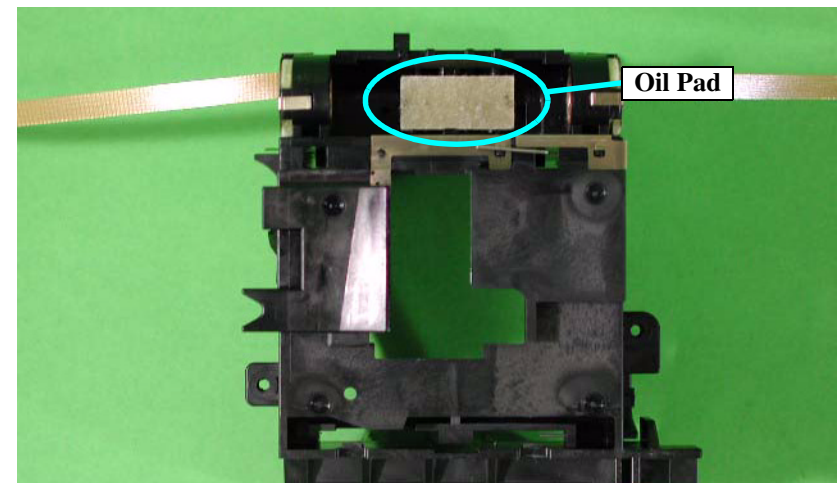

Figure 4-50. Oil Pad Installation

ADJUSTMENT  
REQUIRED

Carry out all of the adjustments in Table 5-1 in the order given when removing or replacing the CR guide shaft.

## CAUTION



Both of the Carriage Unit Bushings are different from the bushes used in previous models because the Oil Pads and fixing brackets which are attached to the bushings (one each per bushing) have different ASP designations from the Carriage Unit because of the manufacturing process and parts delivery method used.

Accordingly, the availability of the bushings as a set should be checked beforehand when quoting for ASP work on the Carriage Unit.

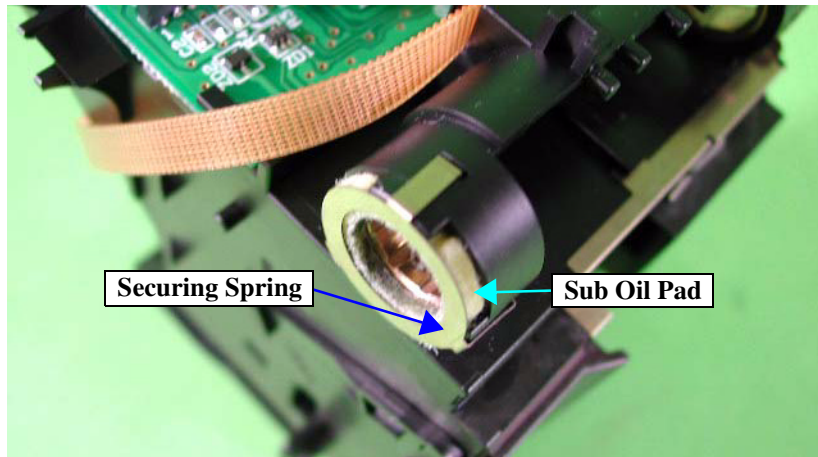

Figure 4-51. Oil Pads and fixing brackets

## 4.2.7 Front Paper Guide Removal

1. Remove the Paper Eject Frame Unit. (Refer to Steps 1 to 10 in Section 4.2.5.)
2. Remove the two EJ Roller Holders Assembly. (Refer to Figure4-52)
3. Remove the two screws (2) (CBS 3x6 {8±1 kgf.cm}) that are securing the Front Paper Guide.

CHECK  
POINT

To remove the EJ Roller Holder, use a flat-tipped screwdriver to lift the EJ Roller Holder upward.

## CAUTION



The procedure below describes the method of removing the Front Paper Guide. If the procedure is not carefully followed, the power coating on the surface of the PF Roller may come off, and this could have an adverse effect on the paper feed pitch to an extent that could be noticeable to the user. Accordingly, when removing the Front Paper Guide, take particular care not to touch the surface of the PF Roller. Furthermore, this should also be observed when installing the PF Roller. Specifically, contact with the surface of the PF Roller can be avoided by rotating it to the front while removing it.

4. Turn the Front Paper Guide to the front and then remove it.

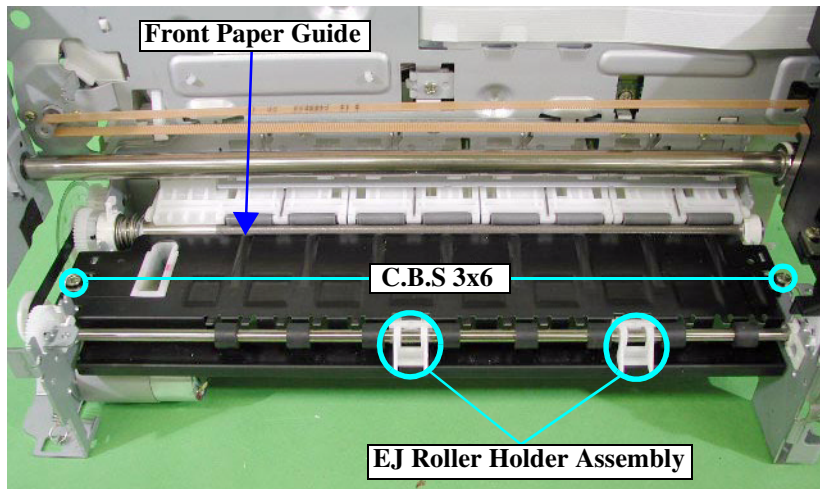

Figure 4-52. Front Paper Guide Removal



Be careful not to break the section of the EJ Roller Holder Assembly shown in the illustration below.

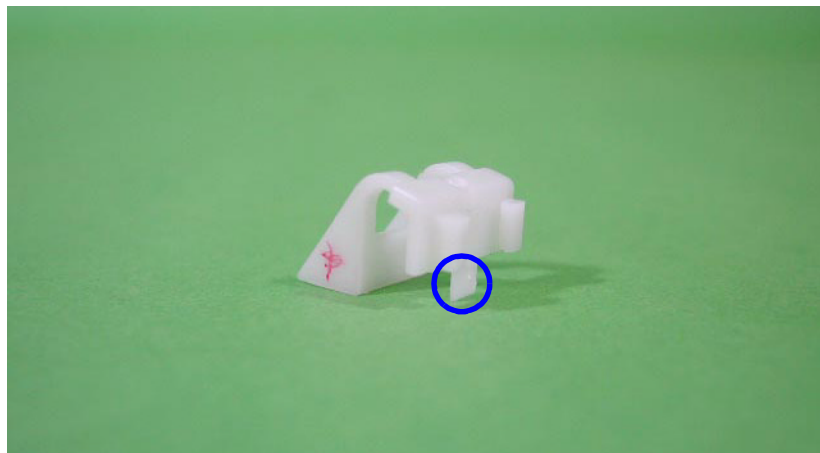

Figure 4-53. EJ Roller Holder

## 4.2.8 EJ Roller Unit Removal

1. Remove the Front Paper Guide. (Refer to Section 4.2.7.)



If not removing the Carriage Unit, move the Carriage Unit to the middle position. (The following procedures can then be carried out even without removing the Carriage Unit.)

2. Remove the EJ Grounding Wire from the mounting hole, and then remove it from the EJ Roller Unit.

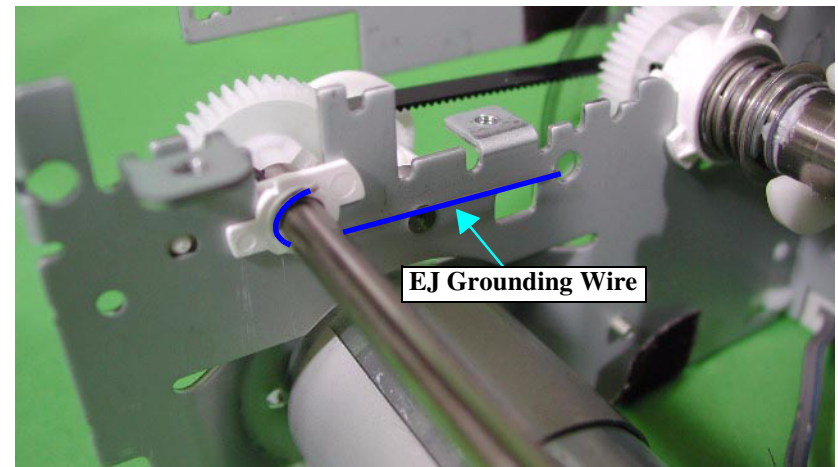

Figure 4-54. EJ Grounding Wire Removal

- Remove the Bushings 5 from the mounting holes at both ends, and turn the EJ Roller Unit upward.

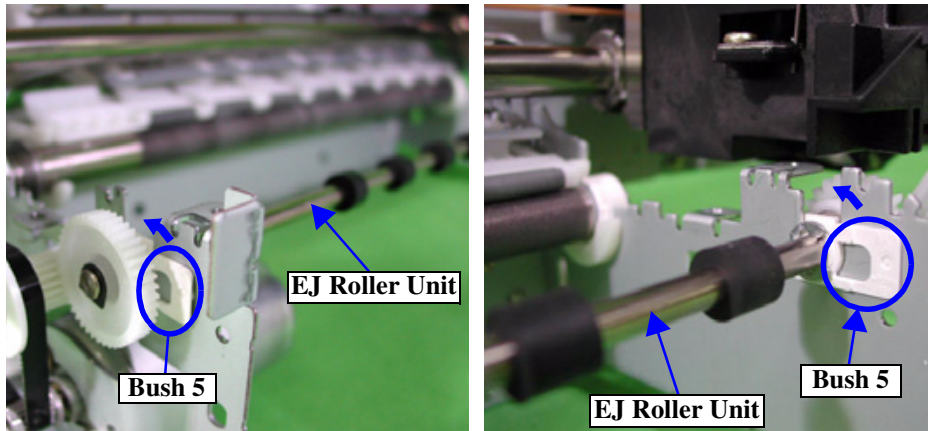

Figure 4-55. EJ Roller Unit Removal

- Lift up the EJ Roller Unit to remove it.



When installing the EJ Roller Unit to the PF Frame, the Shaft side of the CR Lock Lever Unit should be facing to the right.

## 4.2.9 Motor Removal

### 4.2.9.1 PF Motor Removal

- Remove the Printer Mechanism. (Refer to Sections 4.2.1.6)
- Remove the Main Shield Plate (Right) from the Main Board.
- Disconnect the connector (CN14: black 2-pin) from the Main Board Assembly.
- Remove the Extension Spring that is securing the PF Motor.
- Loosen one of the two screws (8) (CC 3x4 (3.5±0.5 kg.cm)) to release the Timing Belt tension. Then remove the Timing Belt for the PF Motor from the PF Motor Pinion Gear.
- Remove the screw (8) (C.C 3x4 {3.5±0.5 kgf.cm}) and the screw (9) (PF Mount {3.5±0.5 kgf.cm}) that are securing the PF Motor Assembly.

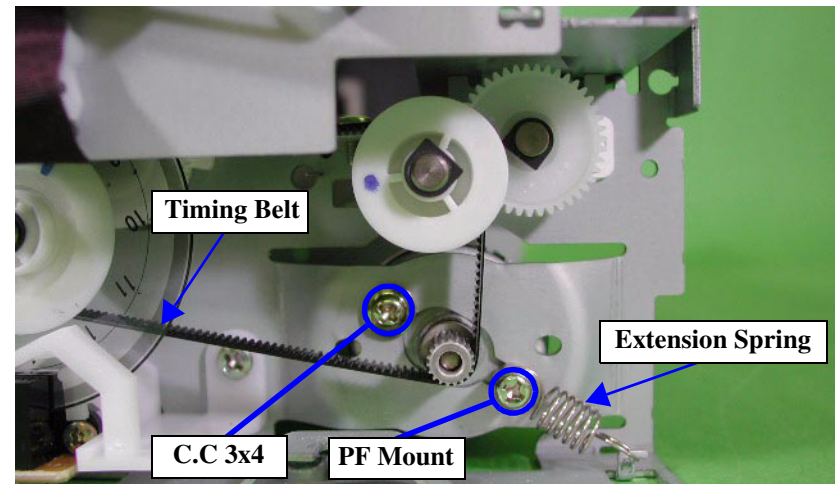

Figure 4-56. PF Motor Assembly Removal (1)



7. Peel off the Acetate Tape that is securing the PF Motor Assembly Harness to the PF Frame Assembly.

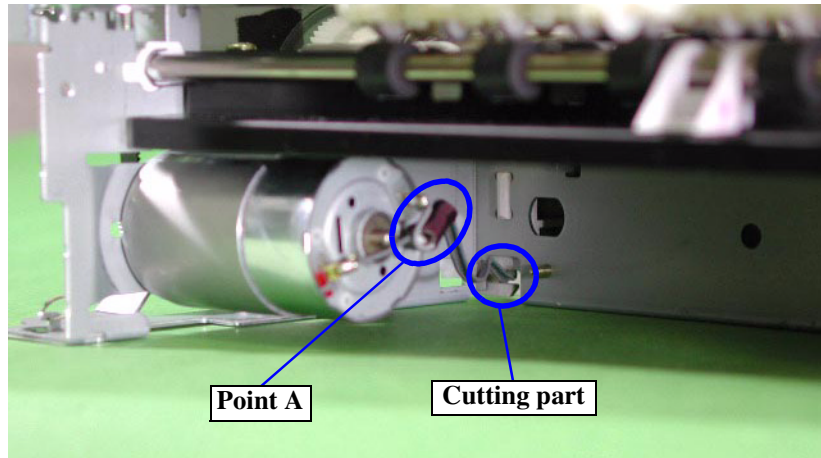

Figure 4-57. PF Motor Assembly Removal (2)

8. Remove the PF Motor Assembly.



**WARNING** When reinstalling the PF Motor, be sure to use the Acetate Tape that was removed in step 7 to re-secure the Harnesses. If this is not done, the Harnesses will get underneath the Printer Mechanism and open circuits or short-circuits may occur.



- The Harnesses should be passed around to the rear through the notches in the corner of the plate.
- There is no Acetate Tape attached to PF Motors which are supplied as spare parts. While referring to point A above, the plus and minus Harnesses should be collected together and attached to the frame.



When the PF Motor is replaced, Bi-d adjustment and Paper Feed Adjustment should be carried out.

#### 4.2.9.2 CR Motor Removal

1. Remove the Printer Mechanism. (Refer to Sections 4.2.1.6)
2. Remove the M/B Support Shield Plate (Right). (Refer to Step 6 of Section 4.2.2)
3. Disconnect the connector (CN14: white 2-pin) from the Main Board Assembly.
4. Remove the two screws (10) (C.P 3x4 {3.5±0.5 kgf.cm}) that are securing the CR Motor Assembly.
5. Remove the Timing Belt from the Pinion Gear on the CR Motor.
6. Remove the CR Motor Assembly.

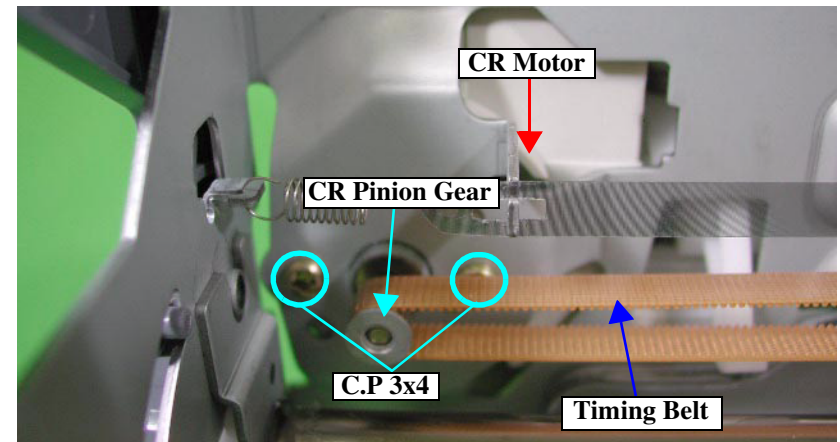

Figure 4-58. CR Motor Assembly Removal



When reattaching the Timing Belt to the CR Motor, the belt tension will be quite strong, so remove the compression spring which is pressing onto the Pulley Driven Holder to make it easier to attach the belt. (Refer to Step 9 in Section 4.2.6.)



## 4.2.10 PE Actuator Removal

1. Remove the ASF Unit. (Refer to Sections 4.2.2)
2. Remove the screw (2) (CBS 3x6 { $8\pm 1$  kgf.cm}) that is securing the PE Actuator.
3. Remove the PE Actuator.

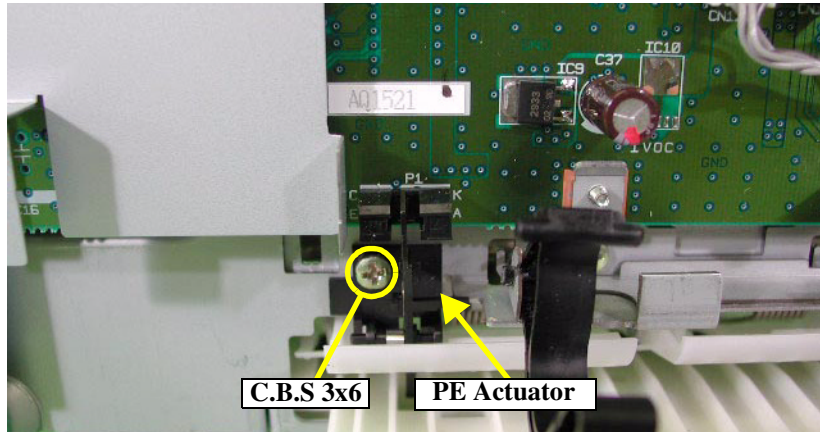

Figure 4-59. PE Actuator Removal

### CHECK POINT



When the PE Actuator is removed together with the base, the Torsion Spring will be easier to remove, so the setting should be made as shown in the diagram below.

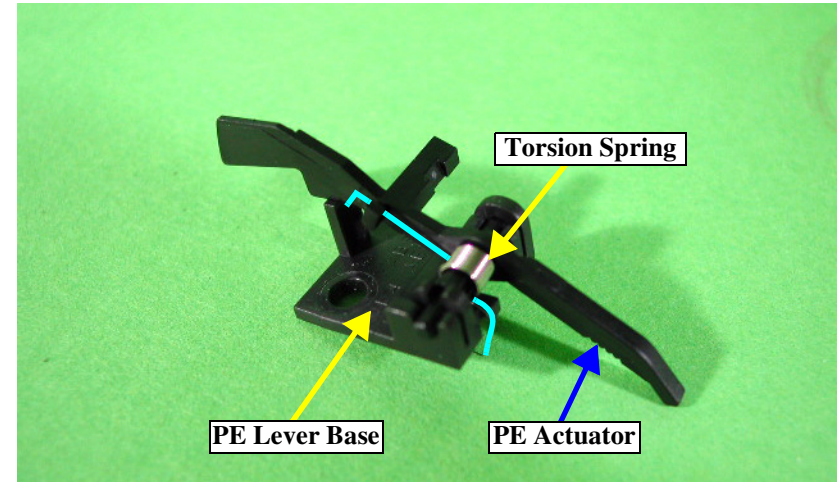

Figure 4-60. PE Actuator

### 4.2.10.1 Encoder Unit Board Removal

1. Remove the Printer Mechanism. (Refer to Sections 4.2.1.6)
2. Disconnect the connector (white 4-pin) from the Encoder Unit Board Assembly.
3. Remove the screw (11)(CBP 2.5x5 { $3.5\pm 0.5$  kgf.cm}) that is securing the Encoder Unit Board Assembly.
4. Remove the Rotary Encoder so that the Encoder Unit Board can be turned to the left.

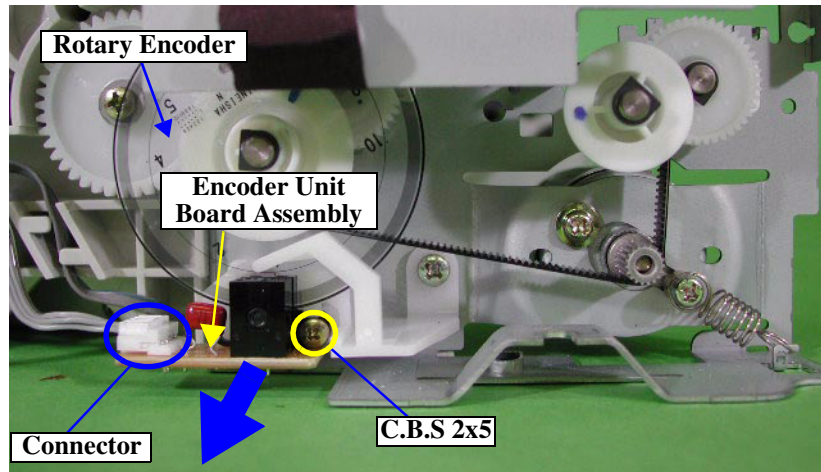

Figure 4-61. Encoder Unit Board Removal



When re-installing the Encoder Unit Board, check that the Rotary Encoder is being clamped correctly by the photo interruptors. If the Rotary Encoder is rubbing against either wall (emitter or receiver), it should be re-installed.

#### 4.2.11 PF Roller Unit Removal

1. Remove the Printer Mechanism. (Refer to Sections 4.2.1.6)
2. Remove the Front Paper Guide. (Refer to Section 4.2.7.)
3. Remove the Timing Belt from the Pinion Gear of the PF Motor. (Refer to Steps 4 and 5 of Section 4.2.9.1.)
4. Remove the Timing Belt from the Combination Gear 12x16.
5. Remove the four screws (2) (CBS 3x6 { $8\pm 1$  kgf.cm}) that are securing the Encoder Unit Board Assembly, and then remove the Encoder Unit Board Assembly.
6. Remove the Spacer that is securing the PF Scale Assembly, and then slide the PF Scale Assembly forward.

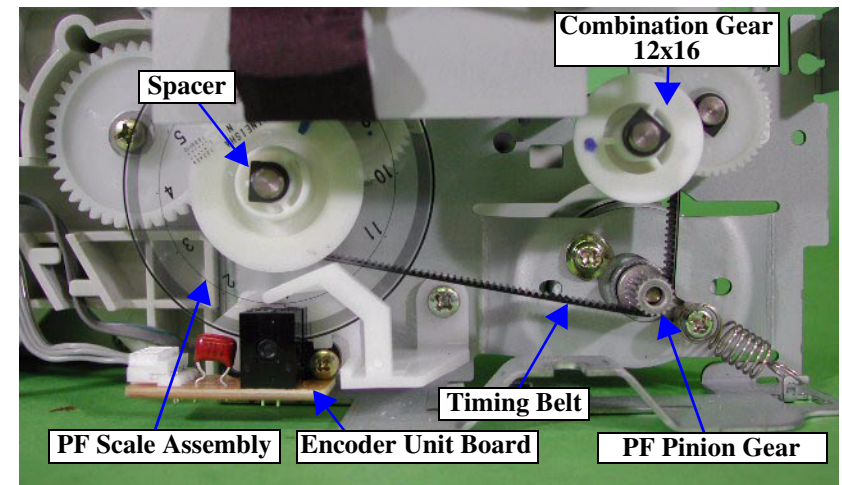

Figure 4-62. PF Scale Assembly Moving



Handle the PF Scale Assembly carefully at all times while working in order to prevent it from becoming broken or otherwise damaged.

7. Remove the PF Grounding Spring.
8. After removing the Bushing at the left side of the PF Roller Unit, turn the PF Roller Unit forward by about 15°, and then move the Shaft to the left by about 5 cm.

**CAUTION**



If the Shaft is moved more than 5 cm to the left, the powder coating on the PF Roller may get scraped against the Hooks at the rear of the Paper Guide and come off. Because of this, move the Shaft to the left little by little, not all at once.

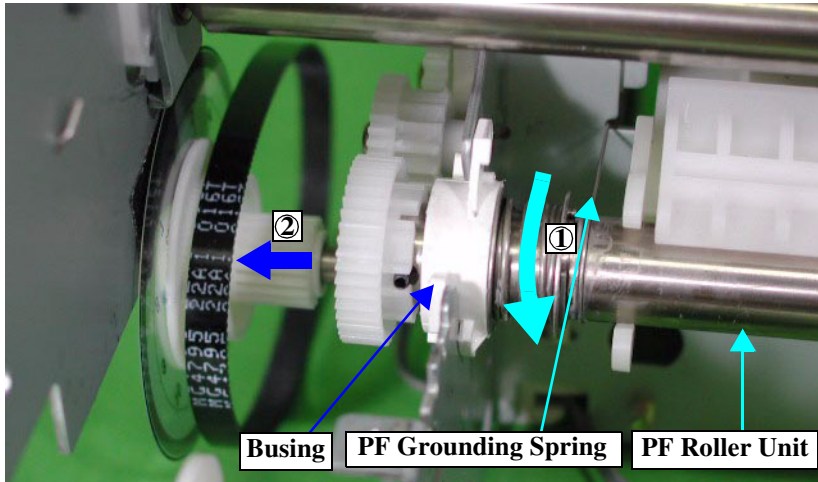

Figure 4-63. PF Roller Unit Moving

- With the left end of the Shaft as a pivot, bring the right end of the Shaft forward to release the Shaft from the Hook at the rear of the Paper Guide, and then remove the whole PF Roller Unit.

**CAUTION**



- If you directly touch the surface of the PF Roller, it will reduce the frictional coefficient and change the paper feeding precision. Therefore, always wear gloves when handling the PF Roller Unit and never touch it directly with your hand.
- Be extremely careful not to damage the surface of the PF Roller.

**ADJUSTMENT REQUIRED**



When the PF Roller is removed or replaced, Bi-d adjustment and paper feed adjustment should be carried out.

## 4.2.12 ASF Unit Disassembly

[ASF Unit right side removal]

- Remove the ASF Unit. (Refer to Section 4.2.2.)
- Insert a flat-tipped screwdriver or similar tool under the two Hooks and push to release them. Then open up the ASF Rear Cover to remove it.

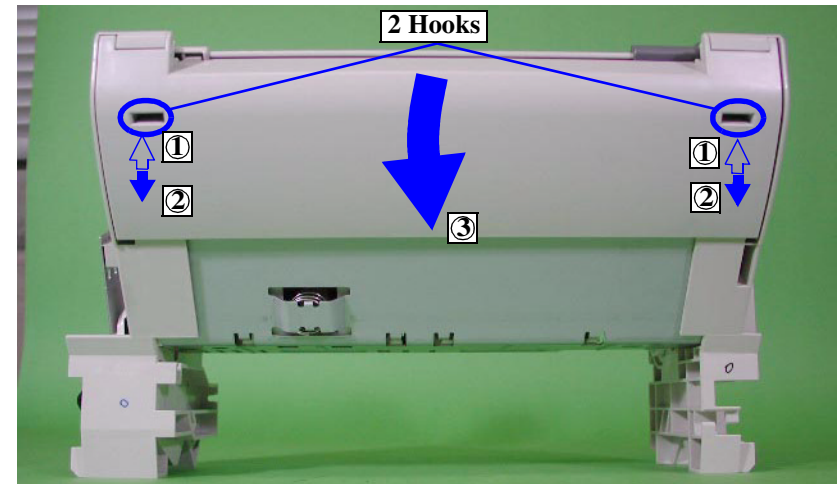

Figure 4-64. ASF Unit Right Side Removal (1)

- Remove a screw (2) (CBP 3x6 {5±1 kgf.cm}) that are securing the Silence Cam Cover, and then remove the Silence Cam Cover.



When reinstalling the Silence Cam Cover, it should be installed so that the hollow at point A is facing outward and so that the two hooks are inserted securely.

- Remove the Extension Spring.
- Disconnect the Torsion Spring from the Silence Lever, and then remove the Silence Lever.
- Remove the Silence Cam.



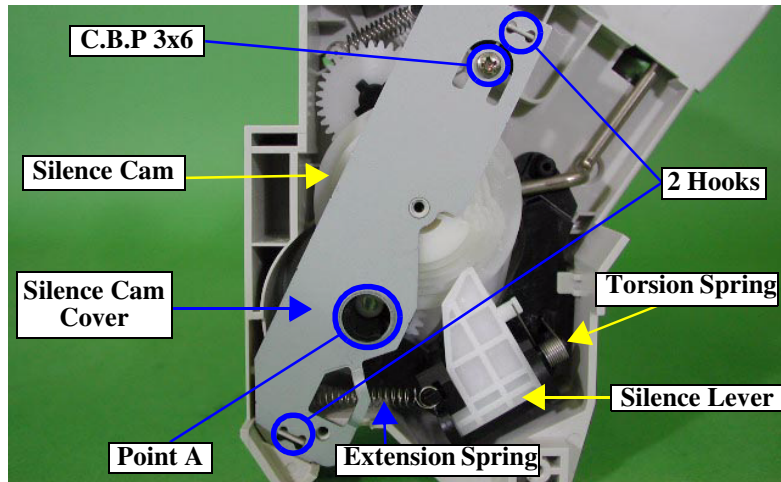

Figure 4-65. ASF Unit Right Side Removal (2)

7. Hold the Hopper Torsion Bar Holder and slide it to the left to release it, and then remove it from the shaft.
8. Disengage the two Hooks, and then remove the Hopper Assembly and the Compression Spring. At this time, remove the Torsion Bar Hopper from the groove at the rear of the Hopper while removing the Hopper Assembly.

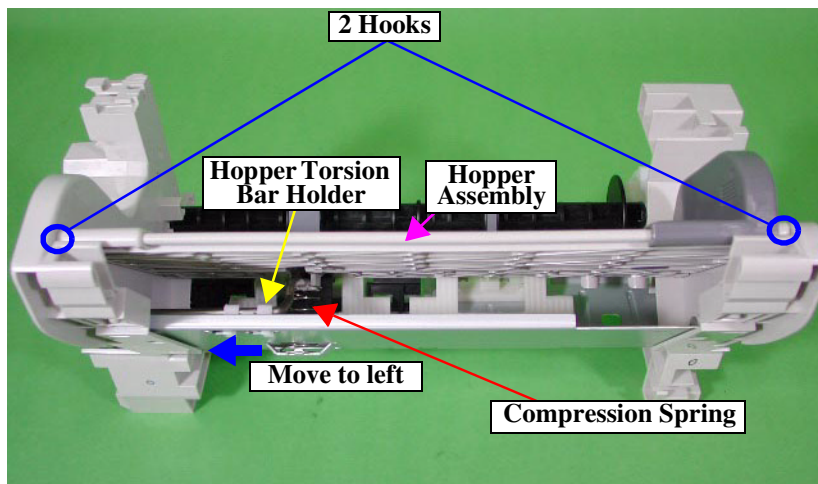

Figure 4-66. ASF Unit Right Side Removal (3)

9. Disengage the Hook from the Hopper Torsion Bar Holder.

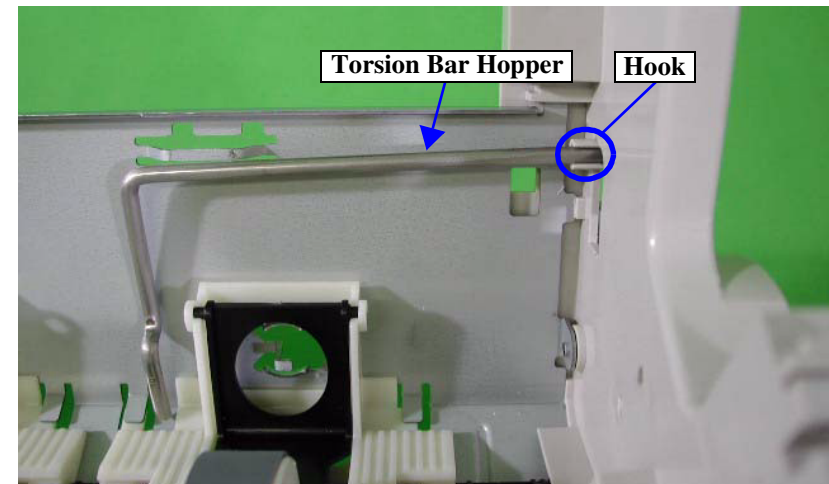

Figure 4-67. ASF Unit Right Side Removal (4)

10. Remove the Spur Gear.



- There is a phase difference between the Spur Gear and the Silence Cam. When reassembling, the condition of the PF Roller should be ascertained from the positions of the phase adjustment screws on the Spur Gear and the Silence Cam so that the PF Roller can be installed correctly. (Refer to Section 4.2.12.1.)
- If the directionality of the Spur Gear is incorrect, it should not be reinstalled to the Shaft. When reinstalling, check the shape carefully and make sure that it fits onto the LD Roller Shaft without needing to apply an excessive amount of force.

11. Remove the Silence Lever Support from the shaft.
12. Remove the Paper Back Lever Support.
13. Remove the Paper Back Lever Cam.



There is a phase difference between the Paper Back Lever Cam and the Silence Cam. When reassembling the ASF, match up the phase (1) between the Spur Gear and the Silence Cam, and then (2) between the Silence Cam and the Paper Back Lever Cam.

14. Remove the Extension Spring.

15. Remove the Pad Brake Holder and Extension Spring 3.02.



The hook that is pulling the Extension Spring can be easily broken, and this can cause the Extension Spring to fall down, so be very careful when handling these parts.

16. Remove the screw (4) (CBS 3x8 {8±1 kgf.cm}) that is securing the ASF Right Frame, and then remove the ASF Right Frame. After the Right Frame has been removed, the Sub Paper Back Lever can also be removed.

17. Remove the Torsion Spring 66.1 or Paper Back Transmission Lever.



When replacing the ASF Right Unit, be careful not to lose the Torsion Spring 66.1 or Paper Back Transmission Lever, as it may fly out at this time.

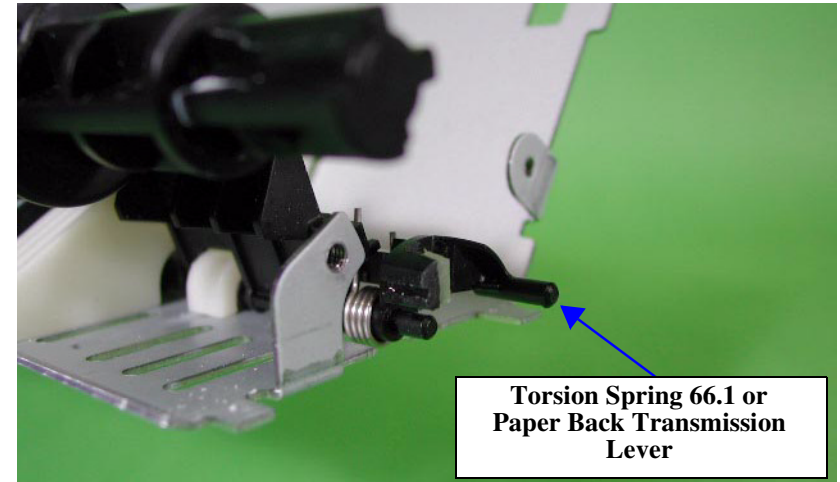

Figure 4-68. ASF Unit Right Side Removal (5)



- Lift the Sub Paper Back Lever up when reinstalling the Right Frame, otherwise it will go underneath the black pawl and will not work properly.
- Sub Paper Back Lever must lock Paper Back Lever.

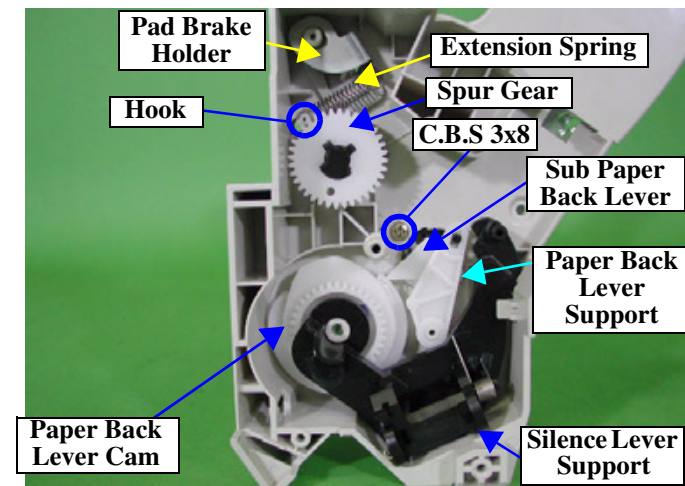

Figure 4-69. ASF Unit Right Side Removal (6)

[ASF Unit left side removal]

18. Remove the Torsion Spring and the Change Lever.

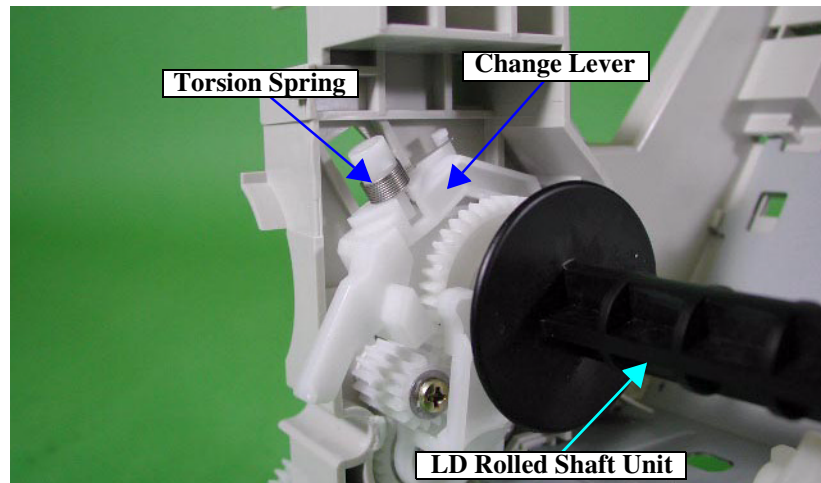

Figure 4-70. ASF Unit Left Side Removal (1)

19. Remove the LD Roller Shaft together with (1) the Drive LD, (2) the Clutch and (3) the Extension Spring 0.5.

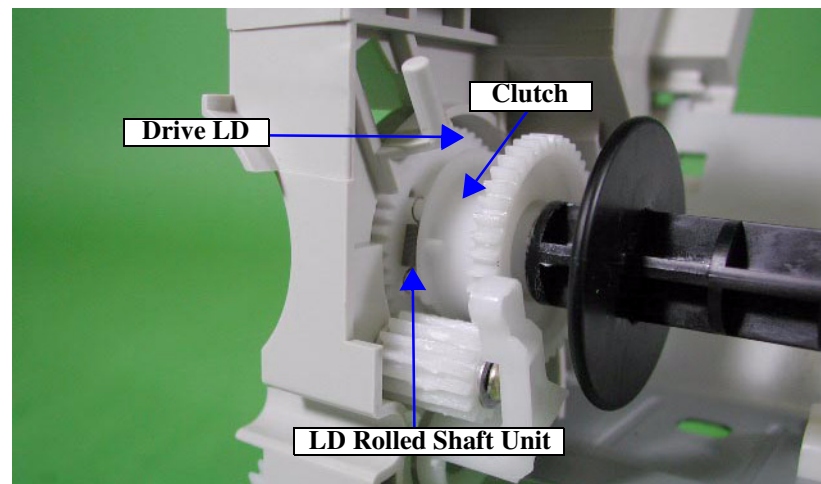

Figure 4-71. ASF Unit Left Side Removal (2)



- There is a U-type Spring at the left end of the Shaft. Set it so that the concave part is on the inside (LD Roller side) and the convex side is on the outside (Frame Left Side).
- At the stage just before inserting the LD Roller Shaft, the following parts must be installed: (1) Drive LD, (2) Clutch, (3) Extension Spring 0.5.

1. Hang Extension Spring 0.5 to the Hook of Drive LD by using tweezers.
2. Hang Extension Spring 0.5 to the Hook of Clutch and insert the Shaft of Drive LD into the hole of Clutch.

20. Remove the screw (7) (CBP 3x6 {5±1 kgf.cm}) that is securing the Combination Gear 18.4, 32.8, and then remove the Combination Gear.

21. Remove the screw (4) (CBS 3x8 {8±1 kgf.cm}) that is securing the ASF Left Frame, and then remove the ASF Left Frame.

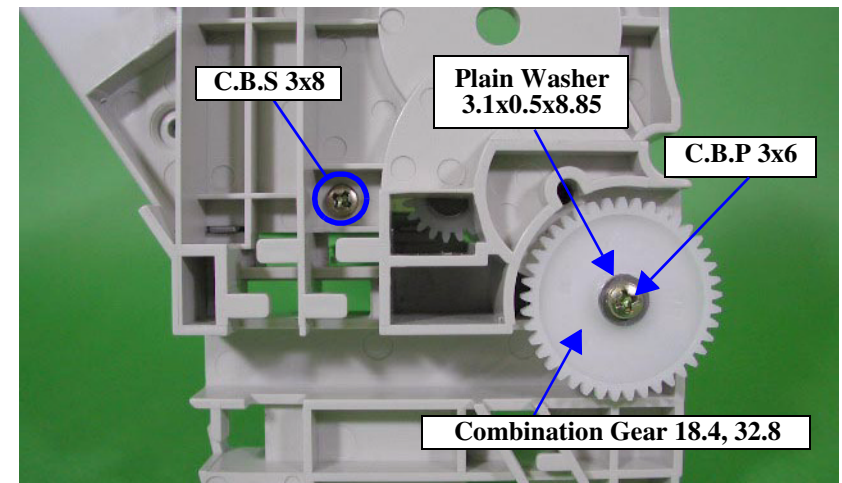

Figure 4-72. ASF Unit Left Side Removal (3)

22. Remove the screw (7) (CBP 3x6 {5±1 kgf.cm}) that is securing the Planetary Gear Set, and then remove the Planetary Gear Set.

23. Remove the screw (7) (CBP 3x6 {5±1 kgf.cm}) that is securing the Spur Gears 12, and then remove the Spur Gears 12.

24. Remove Spur Gear 22.4.



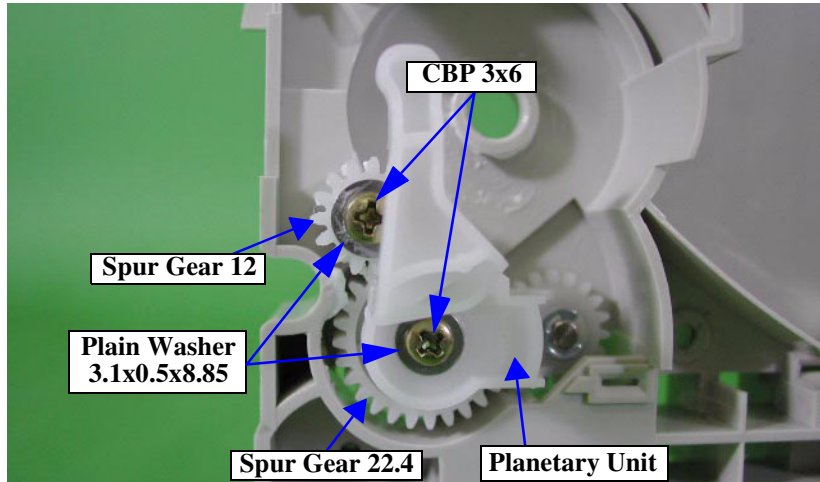

Figure 4-73. ASF Unit Left Side Removal (4)



When installing, Spur Gear 12 can face in either direction, but Spur Gear 22.4 can only face in one direction. It should be placed onto the Shaft so that the lower inner disc is visible. Moreover, the side where the inner disc is at the same height as the outer disc should be facing toward the Frame.

[Paper Back Lever Removal]

25. Disengage the tab of the ASF Middle Holder, and then slide the ASF Middle Holder to the left to remove it. Use tweezers or similar tool to push the tab from underneath the Frame, and in this condition, move the ASF Middle Holder to the left so that it can be released.

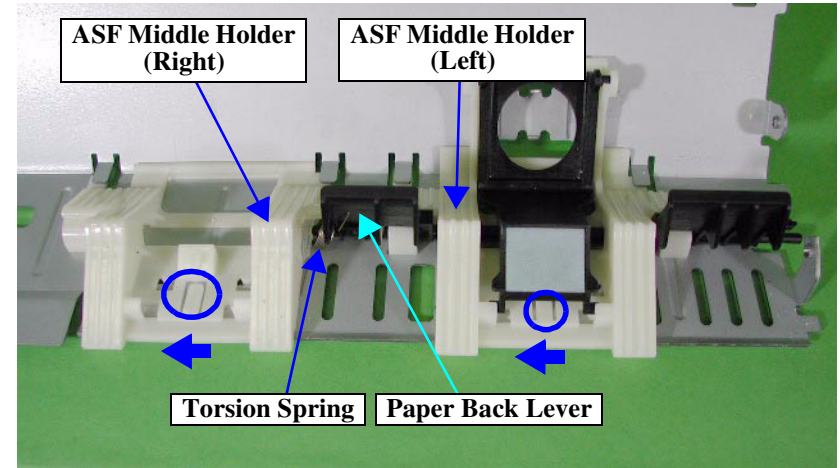

Figure 4-74. Paper Back Lever Removal (1)

26. Disconnect the Torsion Spring from the ASF Middle Holder (Left).

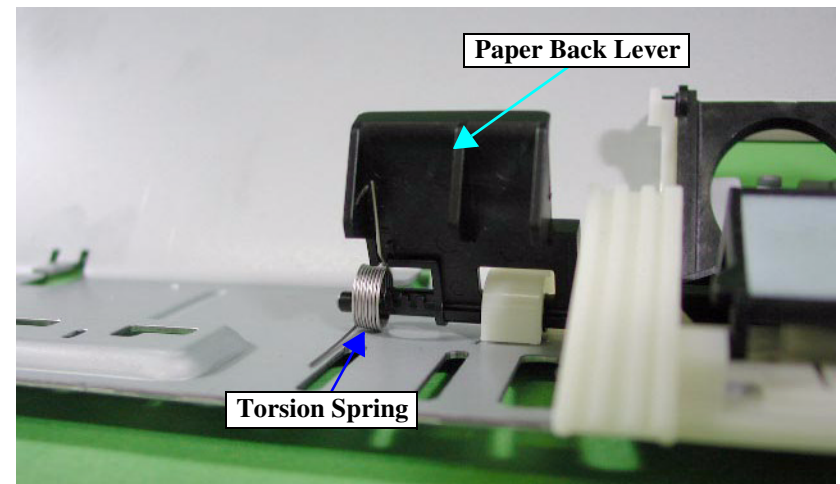

Figure 4-75. Paper Back Lever Removal (2)

**CAUTION**

When removing the ASF Middle Holder (Left), be careful not to lose the Torsion Spring which applies tension to the Paper Back Lever, as it may fly out at this time.

27. Remove the ASF Middle Holder (Right) in the same way as the ASF Middle Holder (Left).
28. Remove the Paper Back Lever. The Paper Back Lever is only secured by means of the two tabs on the ASF Middle Holder (Right).

**REASSEMBLY**

When re-installing the Paper Back Lever to the ASF Middle Holder (Right), insert the two tabs on the ASF Middle Holder (Right) into the two holes in the Paper Back Lever.

**CAUTION**

Don't touch the surface of LD Pad by hand.

**CHECK POINT**

When cleaning away any dust and dirt, use a cloth that has been moistened with alcohol.

**4.2.12.1 ASF Assembly Points**

This section describes the phase adjustments which must be carried out when the ASF has been disassembled and is being reassembled. If these phase adjustments are not made correctly, paper feeding problems or paper eject problems may occur after the ASF has been reinstalled.

The phase adjustments should be carried out correctly in the sequence given below.

**CHECK POINT**

The ASF phase adjustment should be carried out before the following parts have been installed to the ASF Right Frame.

1. Silence Cam
  2. Paper Back Cam Lever
  3. Support Lever Silence
  4. Torsion Spring 1.41
  5. Spur Gear 28.8
  6. Lever Silence
1. Assemble the ASF as far as the point where all of the Gears and other parts can be placed onto the ASF Right Frame.
  2. Install the spur gear 28.8 to the LD Roller Shaft. There is a phase difference between the Spur Gear 28.8 and the LD Roller Shaft, but they can only be installed in the correct position, so check the shapes of each part when installing them.
  3. Place the Paper Back Lever Cam in the specified position. At this time, inset a nail or similar object through the hole on the arc of the Paper Back Lever Cam and the hole in the ASF Right Frame to stop the Cam from moving.

**CHECK POINT**

Use a nail with a diameter of 1.5 mm. If a nail with a diameter of less than 1.5 mm is used, the cam will shift by one notch.



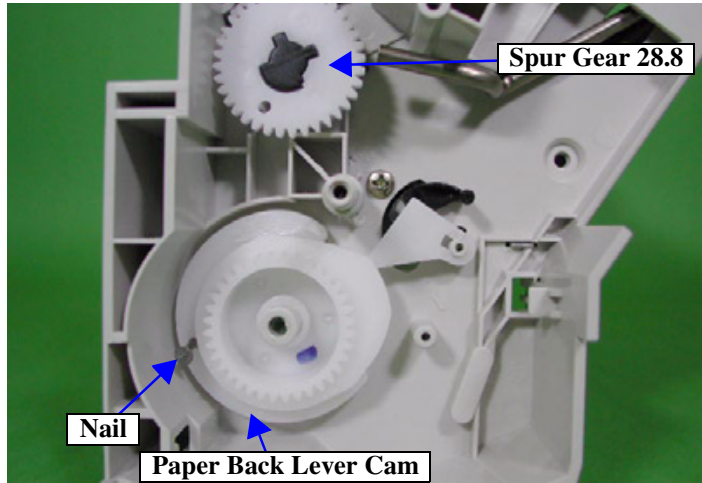

Figure 4-76. Reassembly (1)

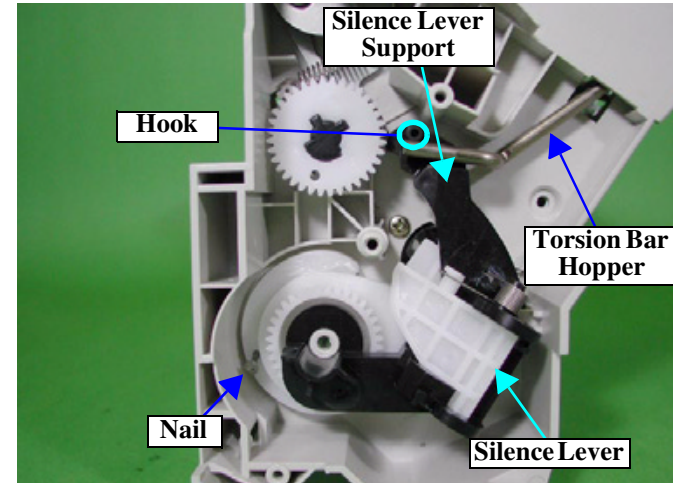

Figure 4-77. Reassembly (2)

4. Move the Support Paper Back Lever to the specified position.
5. Set both a "Silence Lever Support" and "Silence Lever" with its Extension Spring.

6. Insert a nail into the hole at the top of the Silence Cam, and then while inserting the end of the nail into the hole in the arc of the Spur Gear 28.8, move the Silence Cam to the specified position.



When setting the Silence Lever Support in place, hook the end of the Torsion Bar Hopper onto the projection on the Silence Lever Support. Furthermore, if you would like the parts to remain in this condition even when they are let go, you can manually change the relative positions of the Silence Lever and Silence Cam to achieve this.

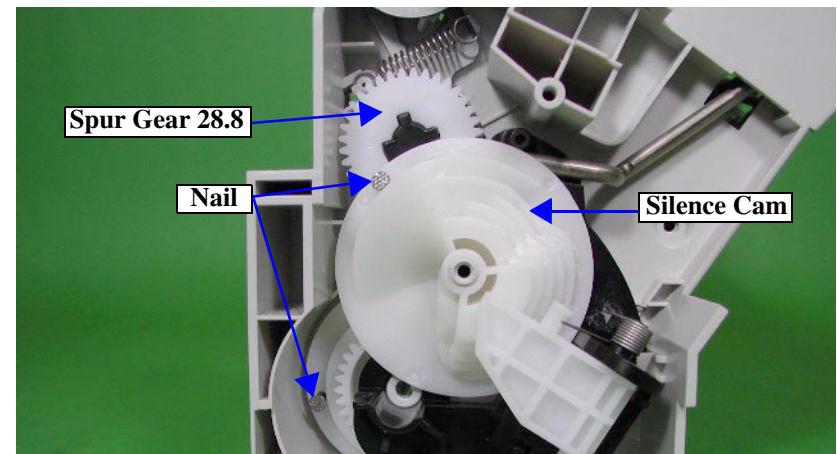

Figure 4-78. Reassembly (3)

7. Remove the two nails, and then check that the two alignment holes are exactly aligned.

### 4.2.13 Rotary Encoder Removal

1. Remove the Main Board Shield Plate (Right). (Refer to Steps 1 and 2 in Section 4.2.3.)
2. Remove the Print Head. (Refer to Section 4.2.5)



- Various adjustments must be carried out after removing or replacing the print head.
- Refer to Table 5-1 in Chapter 5 for the appropriate adjustments to be carried out.



When replacing or re-installing the Print Head, make sure that the CR Guide Plate is correctly installed first. If this is not done, the end of the Print Head may contact the surface of the Paper Guide, which could cause damage to the Print Head during installation.

3. Remove the PE Actuator. (Refer to Section 4.2.10.1)
4. Remove the two screws (2) (CBS 3x6 {8±1 kgf.cm}) that are securing the CR Frame.

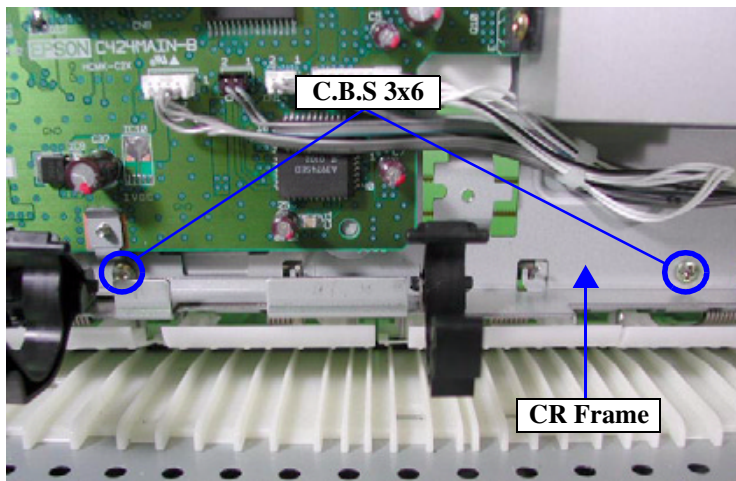

Figure 4-79. Screws Securing the CR Frame

5. Place the CR Guide Shaft so that it will not get damaged, and then lift up the CR Frame and remove it.

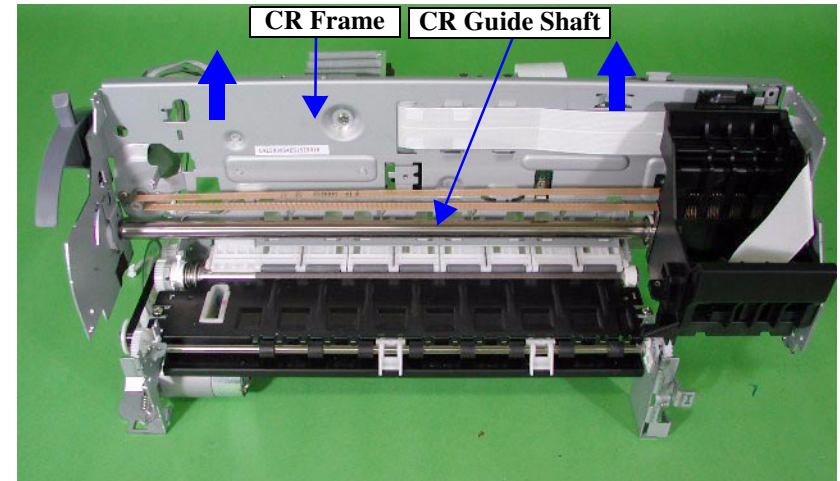

Figure 4-80. CR Frame Removal



If you try to re-use the CR Guide Shaft once it has been damaged, the friction between it and the Carriage Unit will increase and unexpected CR errors may occur.

6. Remove the Encoder Unit Board Assembly. (Refer to Steps 3 to 5 in Section 4.2.11.)
7. Remove the Spacer that are securing the Rotary Encoder, and then remove the Rotary Encoder.



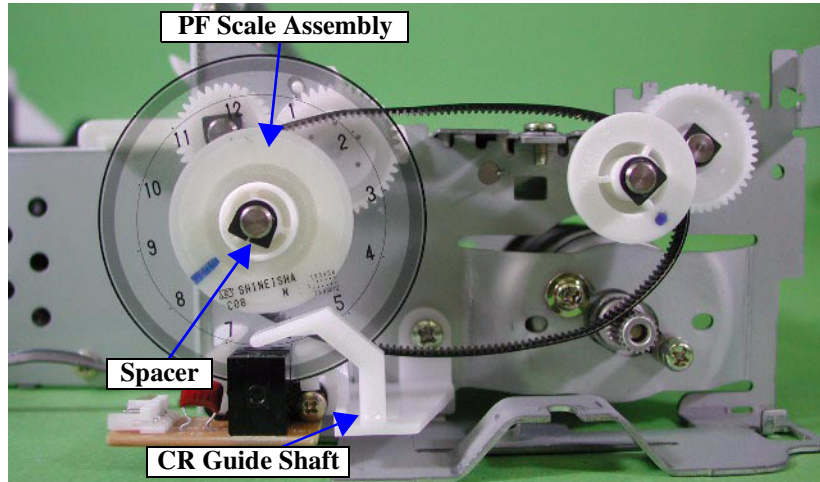

Figure 4-81. Rotary Encoder Removal

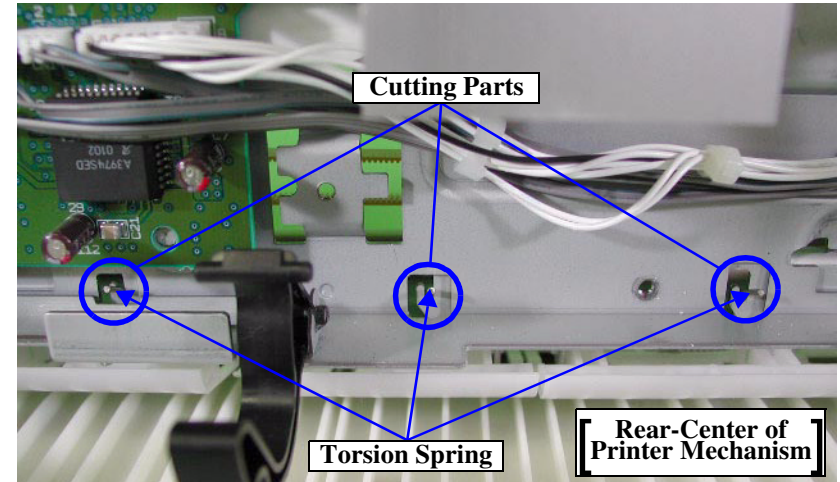

Figure 4-82. Rotary Encoder Installation (1)



Handle the Rotary Encoder carefully at all times while working in order to prevent it from becoming broken or otherwise damaged.



When installing the CR Frame, check the following points.

- Attach the three Torsion Springs which are installed to the middle of the PF Frame to the Cutting Parts at the lower middle part of the CR Frame.
- Insert the nook of the CR Frame into the Cutting Parts at the middle of the PF Frame.
- Place the CR Frame onto the dowel at the rear-right of the PF Frame.

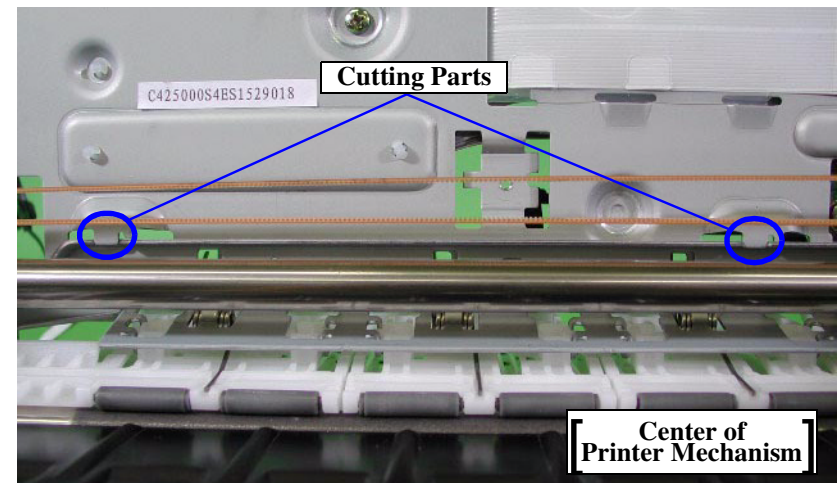

Figure 4-83. Rotary Encoder Installation (2)

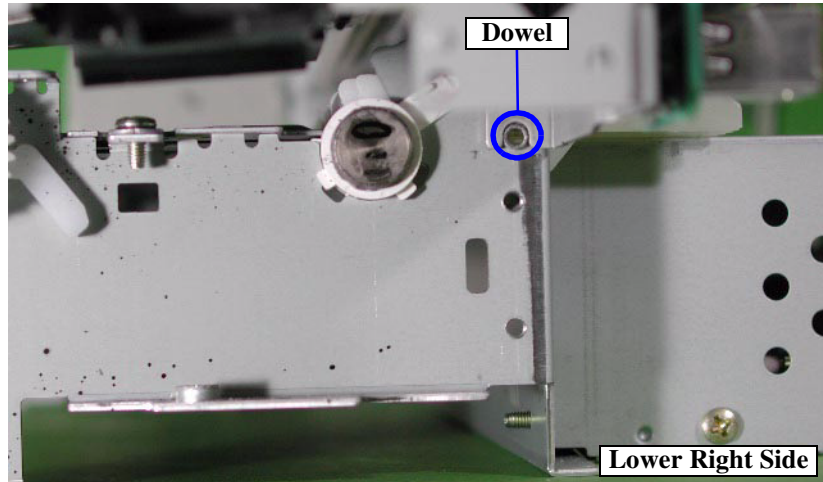

Figure 4-84. Rotary Encoder Installation (3)

CHAPTER

5

# ADJUSTMENT

## 5.1 Overview

This chapter contains all adjustments procedure for Stylus C70/80.

### 5.1.1 Conditions for Each Adjustment

This section includes each adjustment that is required after repairing or replacing specific parts used in the Stylus C70/80. Some of the adjustments have the specified order to perform, depending on the contents of the adjustment. Therefore, observe the points shown under the heading "CAUTION" in below and perform the adjustments properly in the correct order, referring to Table 5-1.



- When adjusting the printer, be sure to refer to Table 5-1 to check for all the necessary adjustment items and perform them in the correct order. Failure to do so may directly affect to print quality adversely.
- In this printer, since the head fixing plate is secured by 2 screws, observe the instruction in this manual to perform the head angle adjustment.
- The C++ language used in the adjustment program only applies to the PCs within run Win95, Win98. Therefore, be sure to run Win95 or Win98 to use the adjustment program, since if other types of PCs such as Macintosh or the one that does not support bi-directional communication system are used, the program does not run properly and adjustments can not be made.
- When performing initial ink charge forcefully using active cartridge, it may possibly be occurred ink out error on the way of its working. In this this, please once more try the same operation after replacing to new ink cartridge.
- Before clearing the waste ink pad counter using the adjustment program, make sure the waste ink pads have been replaced in advance. Lack of this operation may case the ink to leak from the lower case.

Table 5-1. Actions Taken and Corresponding Adjustment in Order

No.	Actions Taken	Step	Corresponding adjustment required
1	Print Head replacement	1	Turn on the printer, and make the ink out (cartridge out) error occur.
		2	Setup the adjustment program. (Refer to Section 5.2.1.)
		3	Input the "Head ID". (Refer to Section 5.2.2.)
		4	Perform "Ink Charge operation" using the adjustment program. (Refer to Section 5.2.3.)
		5	Perform "Head Angle adjustment" using the adjustment program. (Refer to Section 5.2.4.)
		6	Perform "Bi-D adjustment" using the adjustment program. (Refer to Section 5.2.5.)
		7	Perform "PF adjustment" using the adjustment program. (Refer to Section 5.2.6.)
2	C424 Main-B board replacement	1	Check current "USB ID" from the previous main board using the adjustment program and memo. (if you will) (Refer to Section 5.2.7.)
		2	After replacement to main board, turn on the printer, and make the stand-by condition recover.
		3	Setup the adjustment program. (Refer to Section 5.2.1.)
		4	Input the "USB ID". (In case if you could readout USB ID at step 1.) or Input 10-digits serial number. (In case if you couldn't readout USB ID at step 1.) (Refer to Section 5.2.7.)
		5	Perform "EEPROM initialization" using the adjustment program. (Refer to Section 5.2.8.)
		6	Input the "Head ID" using the adjustment program. (Refer to Section 5.2.2.)
		7	Perform "Bi-D adjustment" using the adjustment program. (Refer to Section 5.2.5.)
		8	Perform "PF adjustment" using the adjustment program. (Refer to Section 5.2.6)



**Table 5-1. Actions Taken and Corresponding Adjustment in Order**

No.	Actions Taken	Step	Corresponding adjustment required
3	Carriage shaft replacement or cleaning	1	Perform the "Platen Gap" adjustment. (Refer to Section 5.2.9.)
		2	Setup the adjustment program. (Refer to Section 5.2.1.)
		3	Perform "Head Angle adjustment" using the adjustment program.(Refer to Section 5.2.4.)
		4	Perform "Bi-D adjustment" using the adjustment program. (Refer to Section 5.2.5.)
		5	Perform "PF adjustment" using the adjustment program. (Refer to Section 5.2.6.)
4	ASF replacement or some of parts (*1) concerning paper feed system replacement	1	Setup the adjustment program. (Refer to Section 5.2.1.)
		2	Perform "Bi-D adjustment" using the adjustment program. (Refer to Section 5.2.5.)
		3	Perform "PF adjustment" using the adjustment program. (Refer to Section 5.2.6.)
5	Clogged nozzle Recovery	1	Setup the adjustment program. (Refer to Section 5.2.1.)
		2	Perform "Head cleaning" using adjustment program. (Refer to Section 5.2.10.) Note: If it has no effect, advance to next step.
		3	Perform "Ink Charge" using adjustment program. (Refer to Section 5.2.3)
6	Waste ink pad Replacement	1	Setup the adjustment program. (Refer to Section 5.2.1.)
		2	Replace the waste ink pad
		3	Clear the current protection counter to zero by using "Clear the protection counter values" function on the adjustment program. (Refer to Section 5.2.11.)
7	CR motor replacement	1	Setup the adjustment program. (Refer to Section 5.2.1.)
		2	Perform "Bi-D adjustment" using the adjustment program. (Refer to Section 5.2.5.)

**NOTE:** (\*1):Some of parts concerning paper feed system is, for example 1) PF motor, 2) PF roller, 3) one of gear on ASF.

**NOTE:** In addition to above adjustment items, this chapter mention more adjustment items and its details at your convenience.

1. A4 Normal Paper Printing
2. Page Counter Readout
3. Carriage Pass Counter Readout
3. EEPROM data (Read/Write)
4. Refurbishment for DOA

## 5.2 Adjustment

This section describes the procedure for each adjustment. Be sure to observe the CAUTION and tables in Section 5.1.1 before starting adjustments.

### 5.2.1 Setup the Adjustment Program

Perform the setup operation, which is required prior to actual adjustment operation, by following the steps below.

1. Connect the PC and printer with parallel or USB cable.
2. Turn the printer on.

**NOTE:** To prevent unexpected trouble at setup, wait until the printer completes the power on initialization. Once you encounter the communication error at setup, please accede to following steps to prevent the same mistake.

- 2-1. Turn the printer off.
  - 2-2. Disconnect the AC cable from the AC socket, and connect the AC cable again.
  - 2-3. Turn the printer on. Printer will enter the power on initializing operation unmistakably.
3. Execute the adjustment program (SC807010E\_Win98.exe or Win95.exe) attached to the service manual for the Stylus C70/C80.
  4. The following screen appears.



Figure 5-1. Initial Screen of Stylus C70/C80 Adjustment Program

5. Click the "Model Name" frame, and select either Stylus C80 or Stylus C70.
6. Click the "Interface" frame, and select your target interface port. (Selectable ports are LPT1 to 3, and EPUSB1 to 3.)

**NOTE:** There is no destination setting regardless of Stylus C80 or C70 at this time. All default settings excepting adjustment parameter can be registered by using "EEPROM initialization".

7. Press OK button, then the following main screen appears.

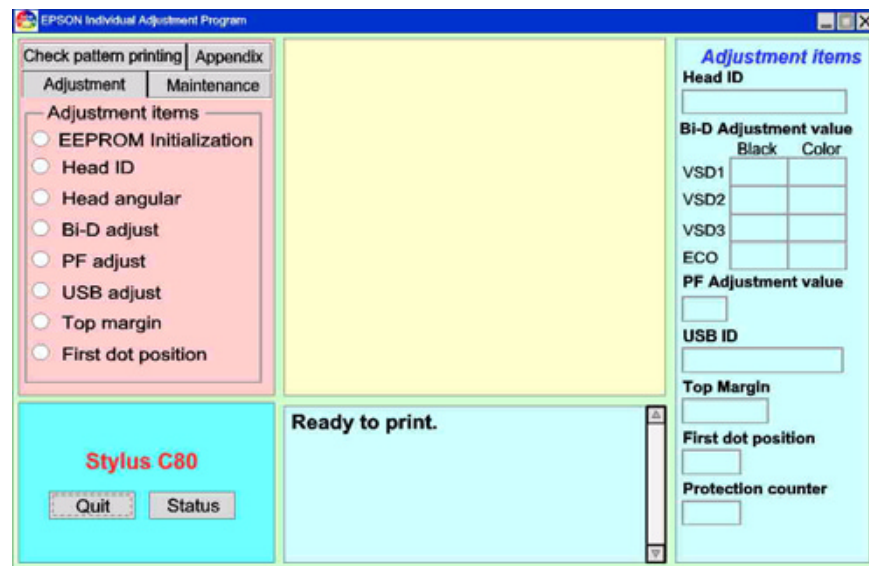

Figure 5-2. Main Screen

**NOTE:** If you select "Quit" button at this spot, printer starts performing the initialization as same to first power on timing to reflect current RAM data to EEPROM, and following screen appears, and following closing screen appears.



**Figure 5-3. Closing Screen**

**NOTE:** In the act of working initialization, if you select "Next" button on above screen, adjustment program will be frozen. So, please wait until the printer completes the initialization. And then press "Next" button if you want to do another action with current connected printer.

**NOTE:** On the other hands, if you press "Quit" button on above screen, the adjustment program will be closed.

## 5.2.2 Head ID Input

This section describes how to input Head ID. Perform this operation under the following conditions:

1. Print head has been replaced.
2. C424 Main-B board has been replaced.

**NOTE:** Always input the Head ID without ink cartridge to prevent unexpected ink out error caused by mismatching between head ID and main board.

1. Replacing to new print head unit with referring Chap 4 "Disassembly and Re-assembly".
2. Setup the adjustment program. Figure-2 Main screen appears. (Refer to Section 5.2.1.)
3. Select "Adjustment" and then "Head ID".
4. Main screen changes as below.

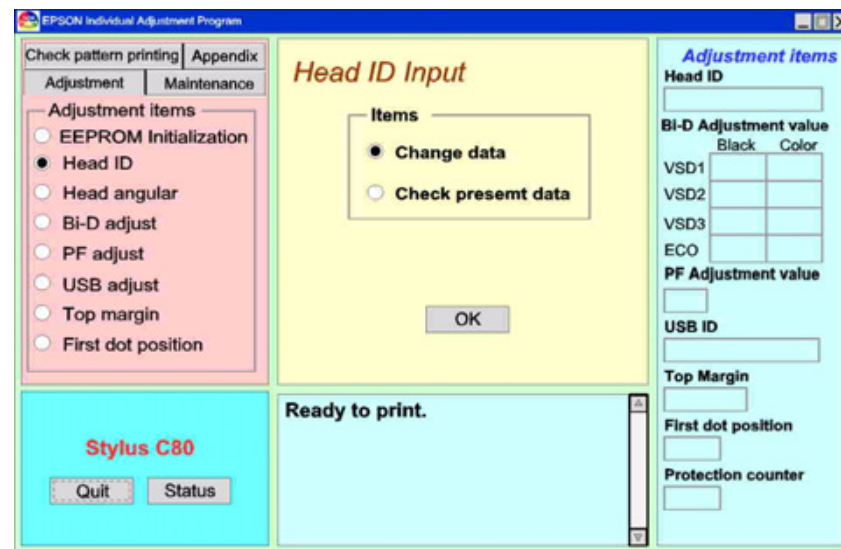

**Figure 5-4. Initial Screen for "Head ID" input**

5. Select "Change data", and then OK button.
6. Following screen appears.

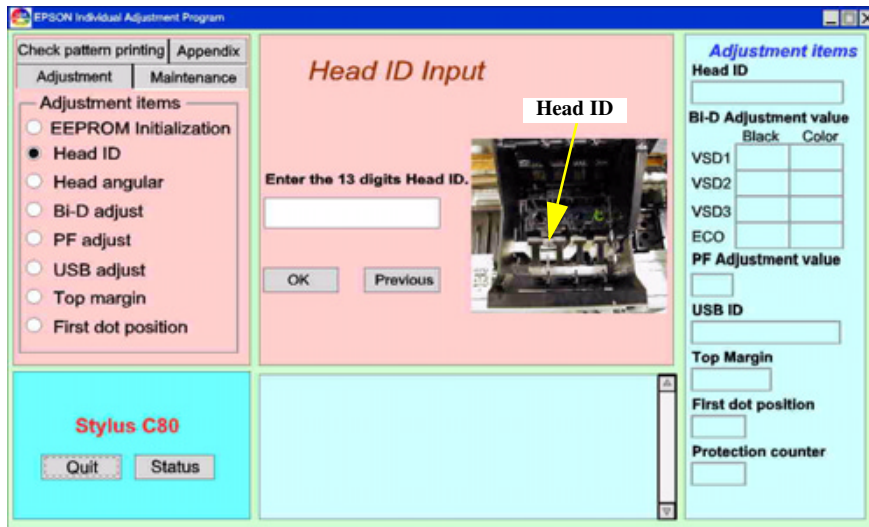

Figure 5-5. "Head ID" input Screen

7. Input 13 digits Head IDs, and press "OK" button.

**NOTE:** Actually, there are 15 digits on the Head ID label. But last 2 digits mentioned small character are not reflected to EEPROM, and are just management ID in the manufactory. Therefore, input 13 digits Head ID only, and do not input 15 digits to prevent check sum error.

8. Following screen appears.

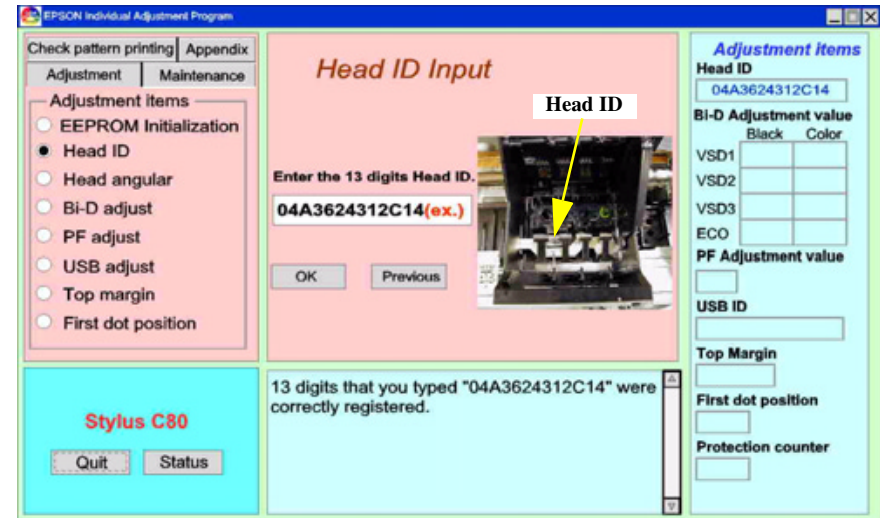

Figure 5-6. "Head ID" Acceptance Screen

**NOTE:** If you mistype the Head ID, adjustment program will automatically detect it, and indicates error message. In this case, once press "Previous" button, and then restart from step 5.

9. To check the typed Head ID whether it's actually registered or not registered, press Previous button once.
10. Program screen will return to Figure 5-4.

- Press "Check present data". You can see your once typed Head IDs on the following screen.

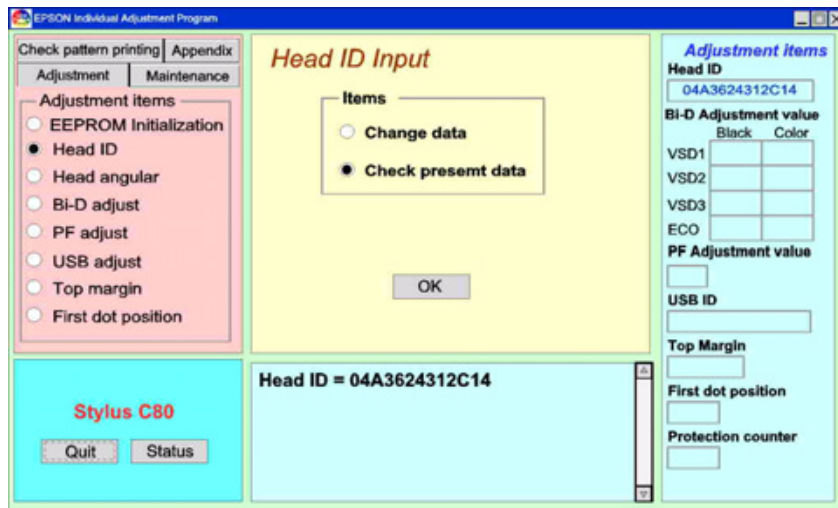

Figure 5-7. "Head ID" Check Screen

### 5.2.3 Ink Charge

This section describes how to perform ink charge. Perform this operation under the following conditions:

- For charging ink to the print head. (After replacing print head)
- For recovering the clogged nozzle(s)

**NOTE:** The sequence that the ink charge function supports is same to initial ink charge. But, since the initial ink charge flag does not operated, you need not to turn off and turn on the printer for executing the initial ink charge.

- Setup the adjustment program. (Refer to Section 5.2.1.)
- Select "Maintenance" and then "Ink Charge". Main screen changes as below.

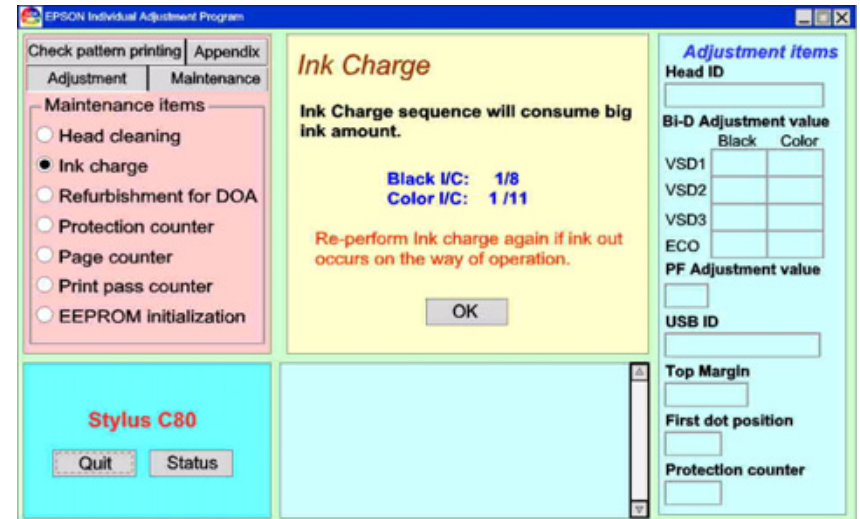

Figure 5-8. "Ink charge" Screen

- Press OK button. Then the initial ink charge operation will be performed.  
(It will take about 90 seconds to complete it.)



- You can see the current ink amount by referring the status monitor visually. And if you can see and understand that the current ink amount cannot keep for the ink charge, you should replace to new ink cartridge(s) beforehand. Once you check current the ink amount.**
- Please do not use at the same time of both adjustment program and Epson printer driver. This will be source of the communication error or freezing the adjustment program. Therefore, if you refer the current ink amount using status monitor, please once close the Epson printer driver, and then use the adjustment program continuously.**

## 5.2.4 Head Angle Adjustment.

This section describes how to perform head angle adjustment. Perform this operation under the following conditions:

- Print head removal or replacing.
- CR guide shaft removal or replacing.
- Moving the print head angle adjust lever.

**NOTE:** Adjust the print head angle without upper case.

**NOTE:** When you check the head angle printing, perform it with exclusive paper such as "Photo Quality Ink Jet Paper" or "Glossy Photo Paper". If you use normal plain paper, you cannot judge and adjust the head angle correctly.

- After replacing or once removing the print head, install the new print head or once removed print head on the carriage unit. And do not attach the upper case.
- Setup the adjustment program. (Refer to Section 5.2.1.)
- Select "Head angular". Following screen appears.

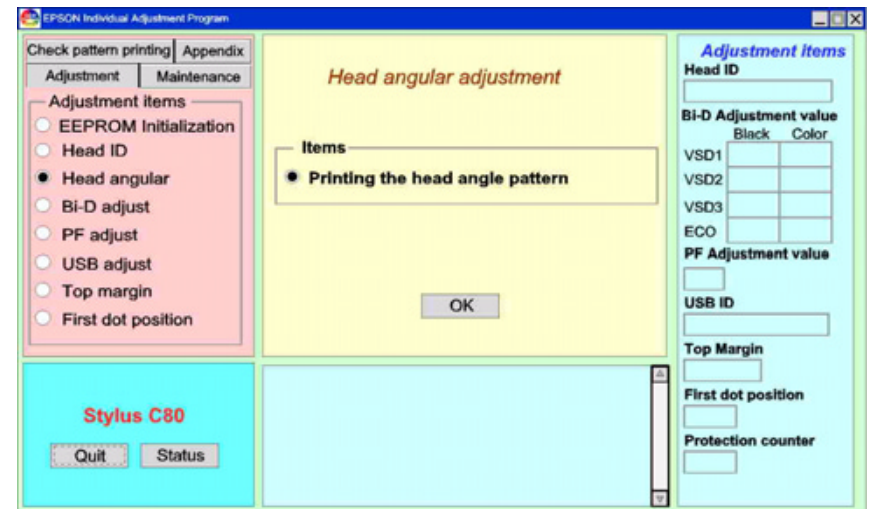

Figure 5-9. "Head Angle" Initial Screen



4. Select "Printing the head angle pattern" and press "OK". Printer will start printing with current head angle setting. During printing, following screen appears, and status message changes after the printing.

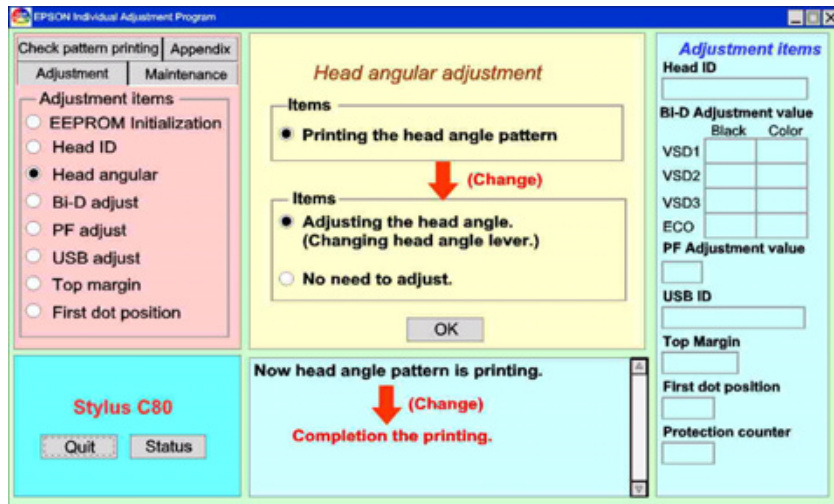

Figure 5-10. "Head Angle" Printing Screen

5. Once the printing completes, the program screen changes as follows.

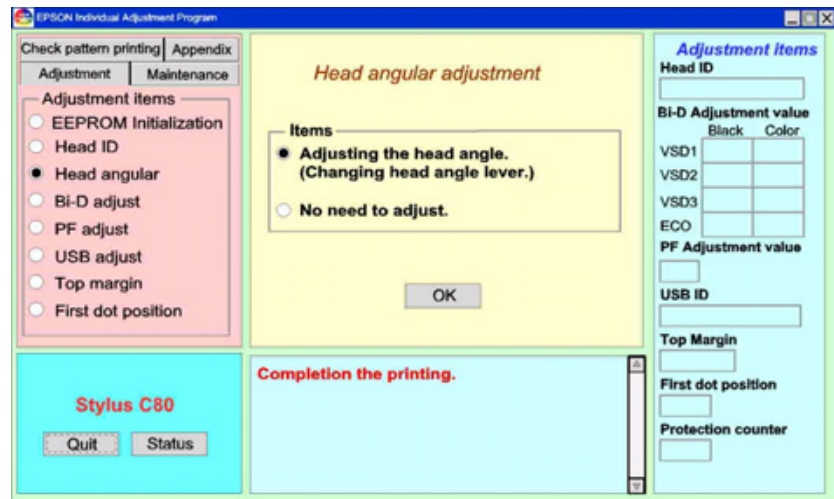

Figure 5-11. "Head Angle" Printing Screen

6. Now, you can see the following printing pattern. And printer is latching its printed paper.

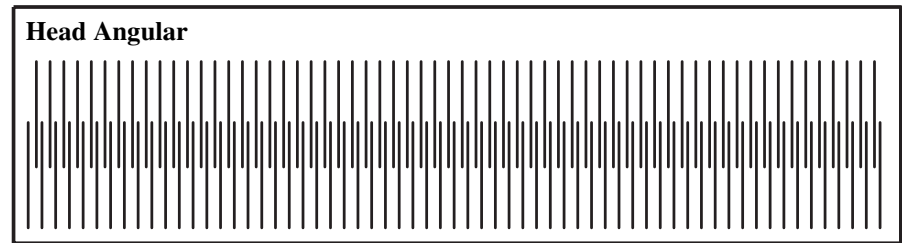

Figure 5-12. "Head Angle" Check Pattern

7. If you judge the once printer paper is OK pattern, select "No need to adjust", and press "OK" button to return the program screen to the "Head angular" initial screen, and to eject a printed paper. Then, you can advance to another adjustment. On the other hands, if you judge it as NG (No Good) pattern, select "Adjusting the head angle" on the program screen and press "OK" button. As soon as the carriage moves to the left side just a little, it stops soon. And program screen changes as follows:

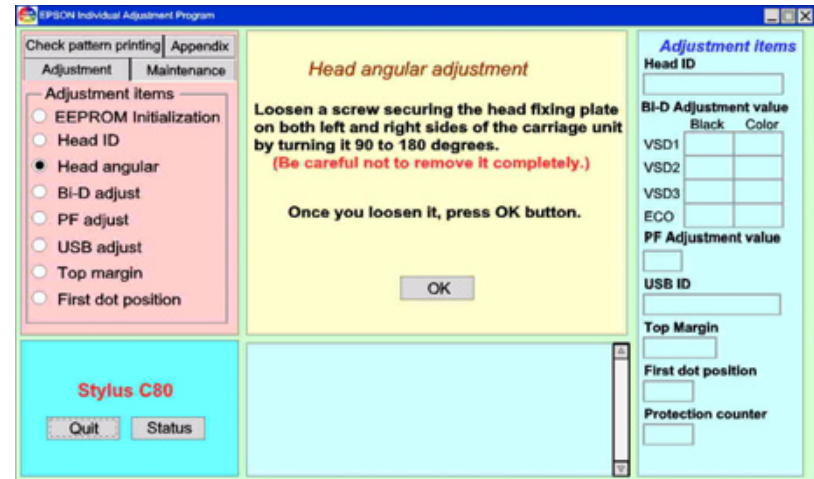

Figure 5-13. Head Angle Adjust Mode 1

**NOTE:** Actually, once you enter this adjustment mode, please complete the head angle adjustment quickly to prevent the print head surface from dry. Especially, during CR is in the out of home position, do not stop your work operation, and return the carriage to the home position once if you have to leave from the printer.

**NOTE:** Before you advance to actual adjustment, you have to know the judgement standard, and how to adjust the head angle. Following explanation is its details.

### JUDGEMENT STANDARD & HOW TO ADJUST HEAD ANGLE

Following is the Judgement standard and mention the relationship between adjust lever operation and reaction of angle check pattern.

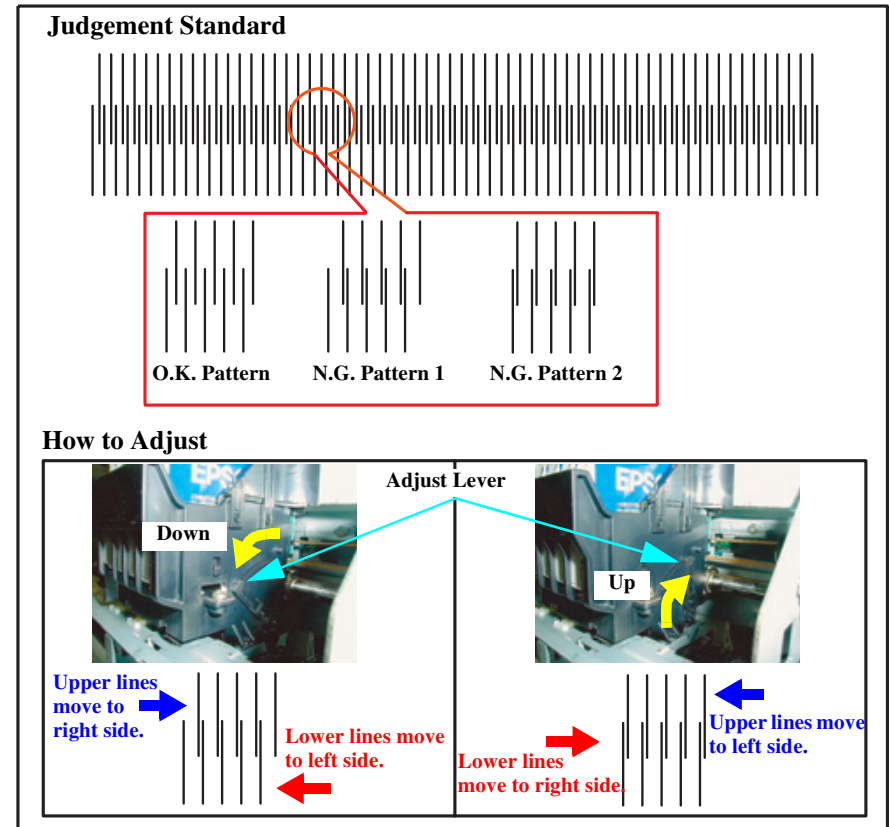

Figure 5-14. Judgement Standard & Relationship between Adjust Lever Operation & Reaction of Angle Check Pattern



1. The ideal condition is that the upper lines and lower lines have to be divided equally each other.
2. The actual operation for changing adjust-lever is quite complicate. So, accede to each step for details.

1. Loosen a screw securing the head fixing plate in the left of the carriage unit by turning it 90° to 180°. (Be careful not to remove it completely.)



Figure 5-15. Location of the left side screw

2. Loosen a screw securing the head fixing plate in the right of the carriage unit by turning it 90° to 180°. (Be careful not to remove it completely.)

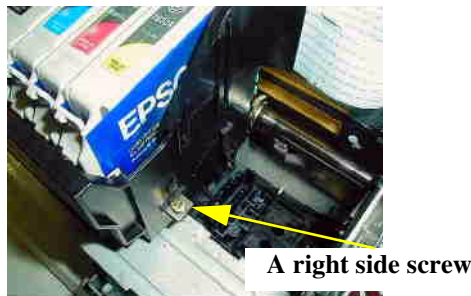

Figure 5-16. Location of the right side screw

3. Press "O.K." button on the current program screen (Figure 5-13). The screen changes as follows.

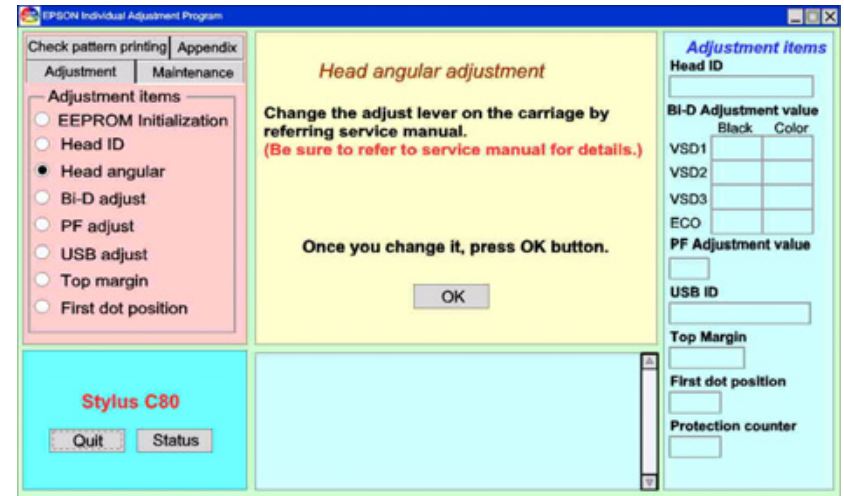

Figure 5-17. Head Angle Adjust Mode 4

4. By referring Figure 5-14 mentioned relationship between adjust lever operation and reaction of angle check pattern, decide your target direction and the location for the head angle adjustment lever.
5. Once you decide your target lever position, accede to followings to change the current adjust lever position to your target position.

Now imagine that head angle condition is in following condition. And you want to change the lever position to more upper side. In this case, you have to change it with acceding to step 1 to step 2 as shown below.

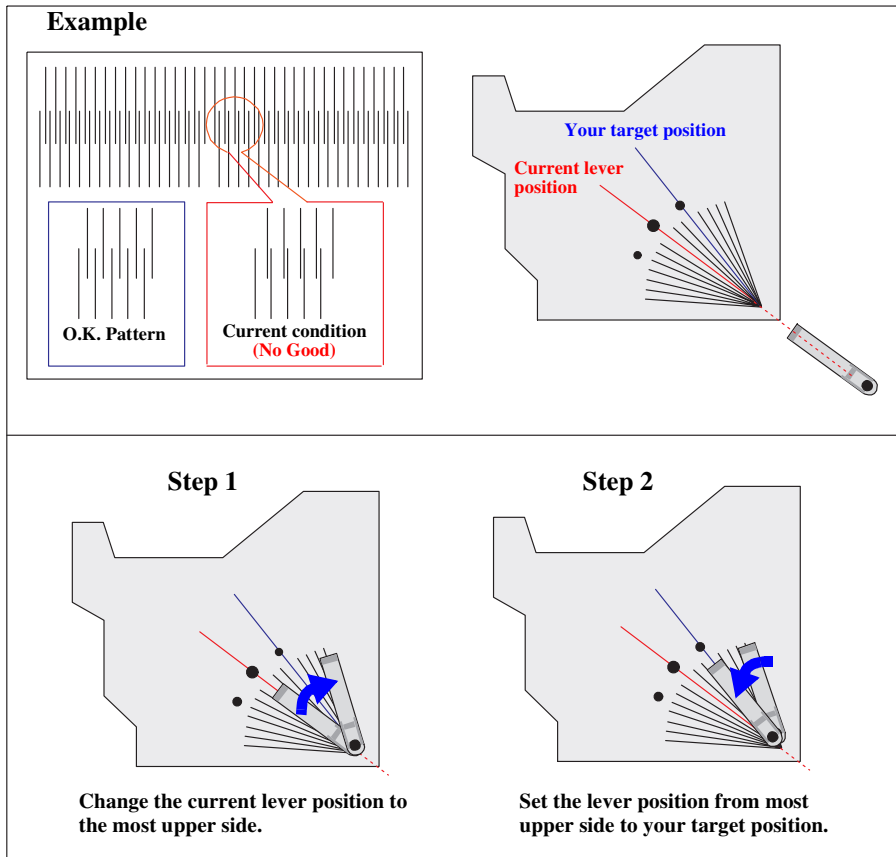

Figure 5-18. How to Adjust the Head Angle Adjust Lever

- Once you set the adjust lever to your target position, push the front of yellow ink cartridge 2 or 3 times by your fingers or the screwdriver.



Figure 5-19. Pushing the Yellow Ink Cartridge

- Press "O.K." button on the current program screen. (Figure 5-17) Following screen appears.

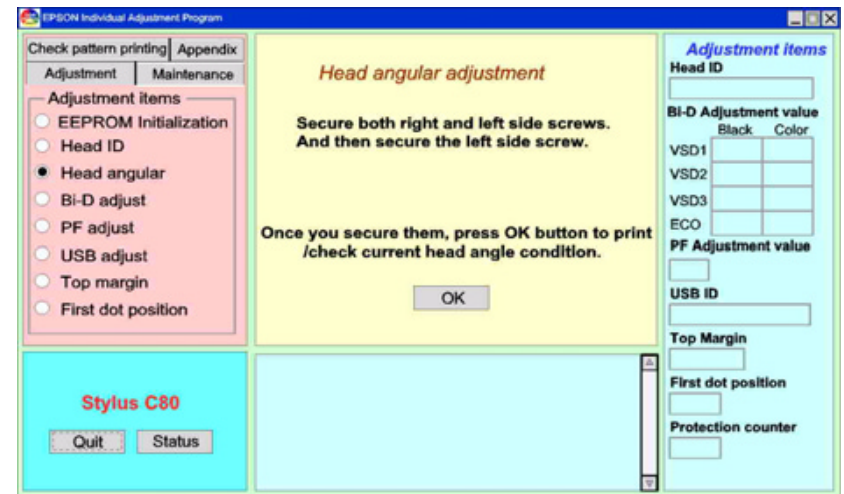

Figure 5-20. Head Angle Adjust Mode 5

8. Check the printed pattern whether you can accept or not by referring Figure 5-14.
9. Program screen returns to Figure 5-10, and you can select either "Adjust the head angle" or "No need to adjust". And then continue the another adjustment such as Bi-D and PF adjustment by selecting left option window.

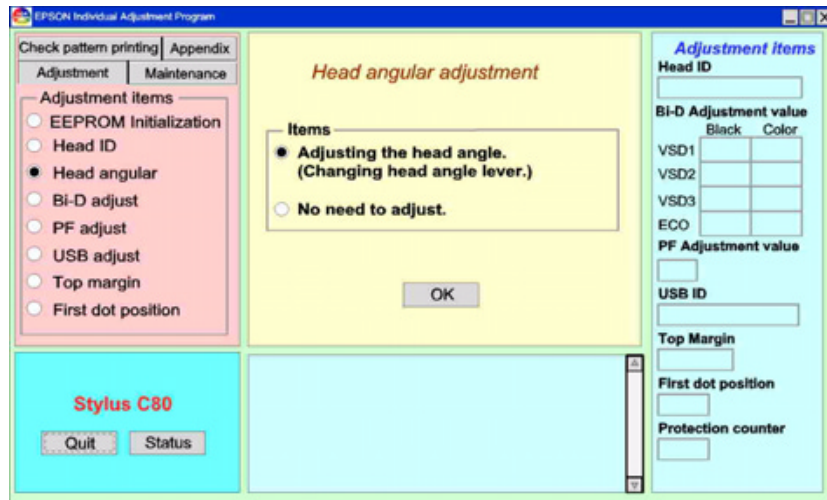

Figure 5-21. Head Angle Adjust Mode 6

10. In case when you want to re-adjust, perform step 4 to step 16 until you can accept the adjustment has completed.

### 5.2.5 Bi-D Adjustment

This section describes how to make Bi-D (Bi-directional) adjustment. This adjustment must be made under the following conditions.

*NOTE: The printer driver utility supports this adjustment, also.*

1. Print Head has been replaced/removed.
  2. Vertical lines are not aligned. (A print problem has occurred.)
  3. C424 Main-B board has been replaced.
  4. Carriage motor has been replaced.
1. Setup the adjustment program. Main screen (Figure 5-2) appears. (Refer to Section 5.2.1.)
  2. Select "Adjustment" and then "Bi-D adjust".
  3. Main screen changes as below.

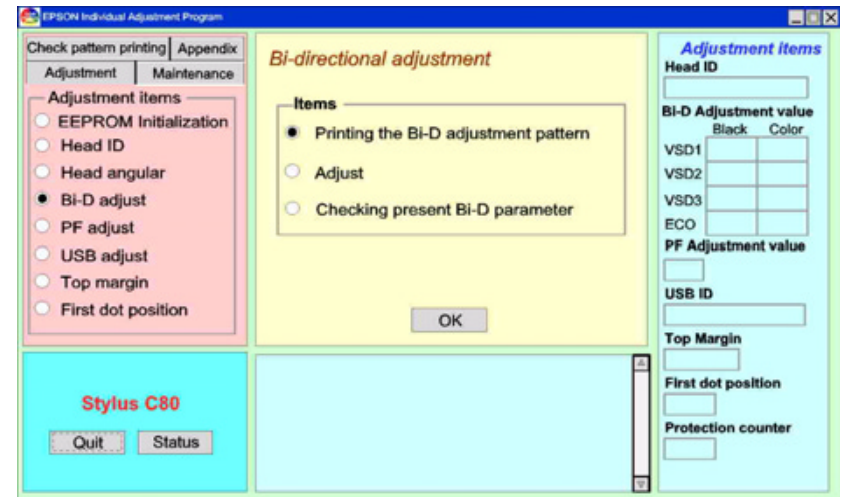

Figure 5-22. Bi-D Adjustment Initial Screen



**NOTE:** The following four items are adjusted with the Bi-D adjustment.

1. Variable Sized Dot 1 (for 360<H> x 360<V> dpi printing)
2. Variable Sized Dot 2 (for 720<H> x 720<V> dpi or for 360<H> x 720<V> dpi printing)
3. Variable Sized Dot 3 (for 1440<H> x 720<V> dpi printing)
4. Economy black dot (for 360<H> x 180<V> dpi printing)

**NOTE:** Also, the Bi-D adjustment has 2 modes for both black and color adjustment.

4. Select "Printing the Bi-D adjustment pattern", and press "O.K." button. Printer starts printing Bi-D pattern with reflecting current registered parameters. Following is the next screen indicating during the Bi-D pattern print. (2 papers are required to print out completely.)

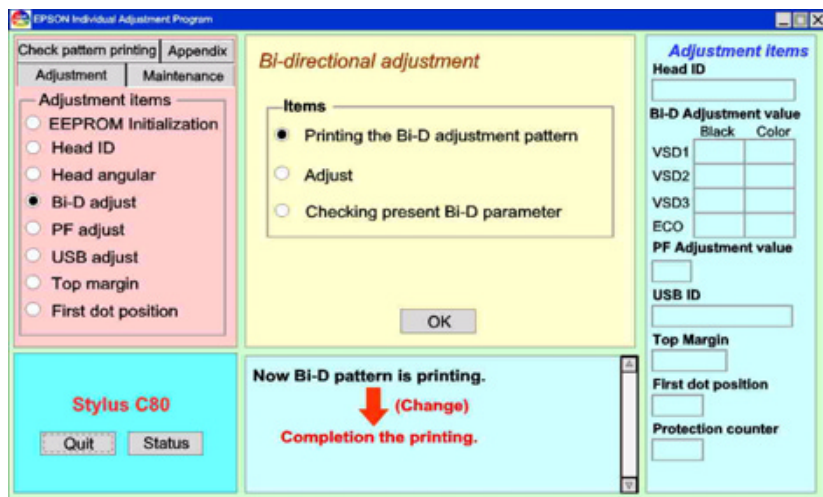
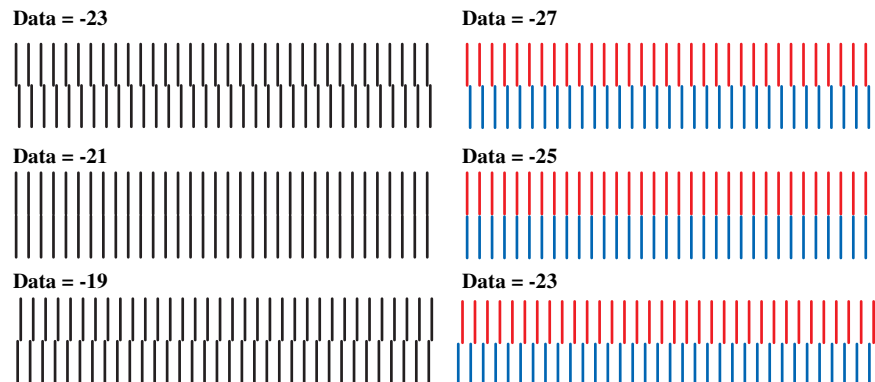

Figure 5-23. Program Screen during the Bi-D pattern print

5. A Bi-D adjustment pattern includes items shown in the sample in figure below. Following shows the 1<sup>st</sup> page pattern,

**Bi-D Adjustment**

**Variable DOT**



**Variable 2 DOT**

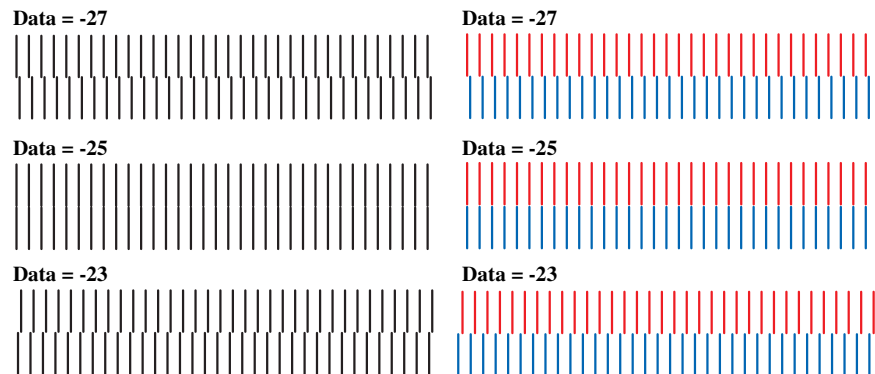
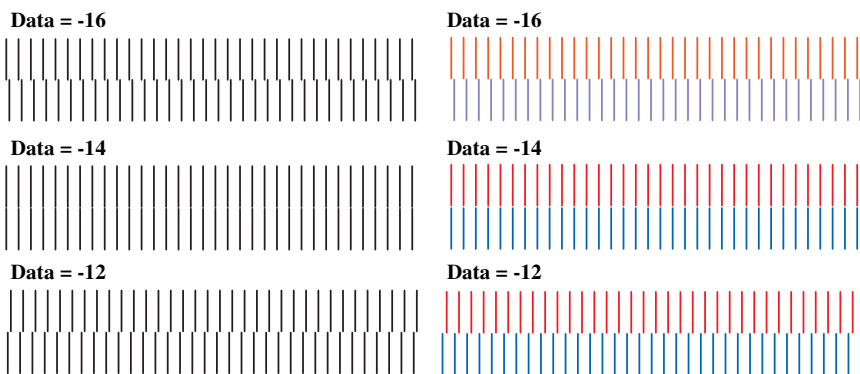

Figure 5-24. Bi-D Pattern printed on 1<sup>st</sup> page



And following shows the 2<sup>nd</sup> page pattern.

**Variable 3 DOT**



**ECO DOT**

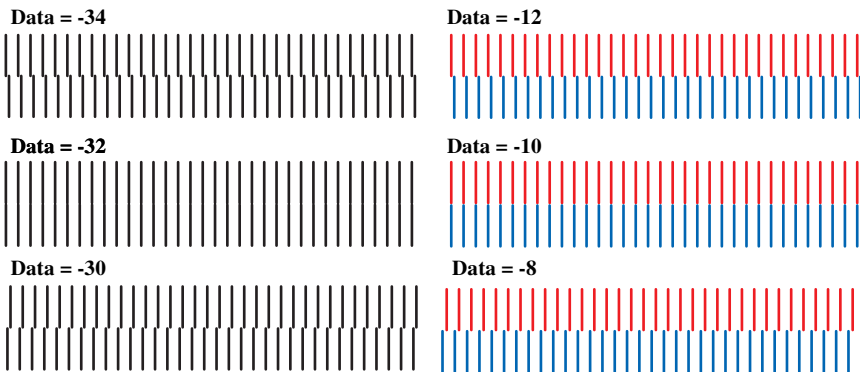

**Figure 5-25. Bi-D Pattern printed on 2<sup>nd</sup> page**

- Among the patterns for each four items, select the value for the most closely aligned vertical line. Note if none of the lines in completely aligned, you can select the value for the most closely aligned pattern. Then center value for the next adjustment pattern print will be replaced and reflected accordingly.

- Select "Adjust" and press "O.K." button in the current program screen. Following next screen appears.

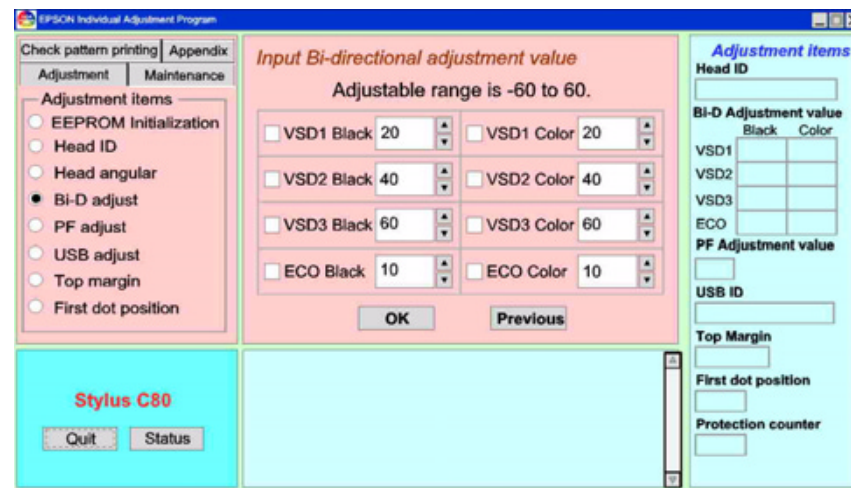

**Figure 5-26. Bi-D Adjust Mode 1**

*NOTE: All parameters that Figure 5-26 indicates has actually readout from the EEPROM on the main board.*

*NOTE: The adjustable range is -60 to 60.*

- As the up/down arrow key is pressed, the indicated value increases/decreases. Also, you can directly input your expected value in the indicator.

*NOTE: You need to input 8 values for all dot types. But, if the actual printed pattern had some completely aligned lines, you need not to input it, and then you can skip and select another dot type.*

- Press "O.K." button on above screen after inputting all values. You can see all values that EEPROM has accepted and registered.

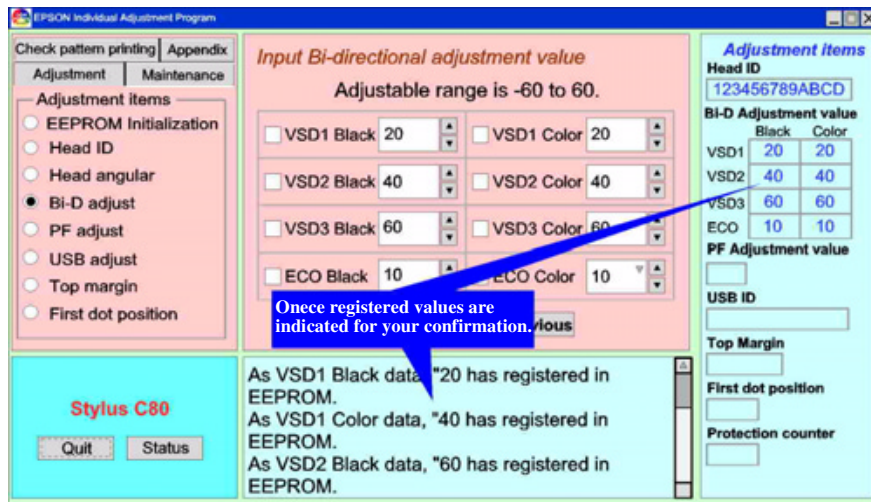

Figure 5-27. Bi-D Adjust Mode 2

**NOTE:** You need not to check your once registered value on the Figure 5-23 screen after completing input. (Option name is "Checking present Bi-D parameter") The all values have already reflected to EEPROM, and status window shows its once registered values.

- Press "Previous" button to return the program screen to Figure 5-22 Bi-D adjustment initial screen.
- Select "Printing the B-D adjustment pattern" to check the changed values again.
- Repeat step 4 to step 11 until you judge all vertical lines are completely aligned.
- Once you complete adjustment, you can advance to next adjustment from Figure 5-23 screen.

## 5.2.6 PF Adjustment

This section describes how to make PF adjustment. This adjustment must be made under the following conditions.

**NOTE:** The printer driver utility supports the adjustment, also.

- Print Head has been replaced/removed.
- Horizontal white line appears.
- C424 Main-B board has been replaced.
- Paper Feed motor has been replaced.
- A parts concerning to paper feed system such as ASF or a gear has been replaced/removed.

- Setup the adjustment program. Main screen (Figure 5-2) appears. (Refer to Section 5.2.1.)
- Select "Adjustment" and then "PF adjust".
- Main screen changes as below.

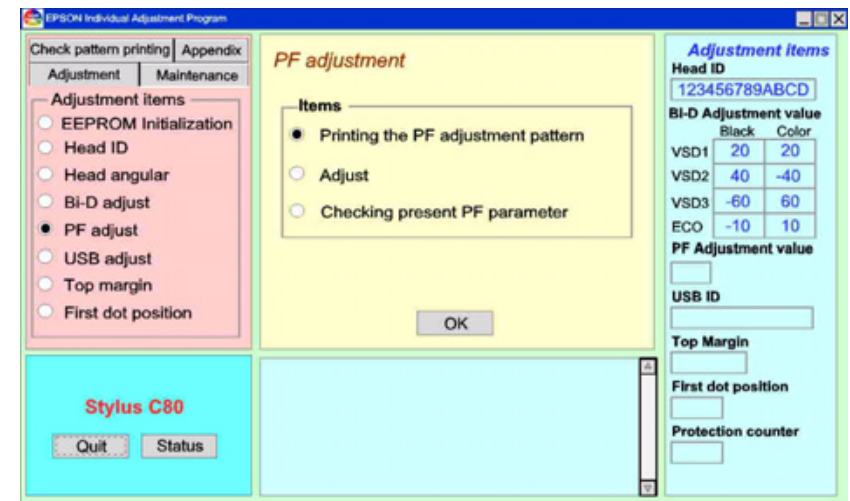

Figure 5-28. PF Adjustment Initial Screen

- Select "Printing the "Printing the PF adjustment pattern", and press "O.K." button on the screen. Printer will start printing the PF adjustment pattern with reflecting current registered parameter. During printing, program screen changes from the initial screen as shown figure below.

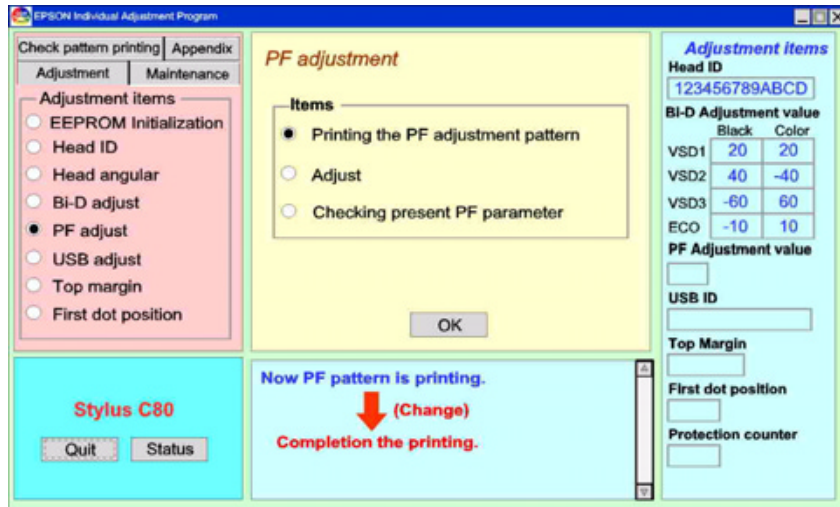

Figure 5-29. Screen Indication during PF Adjust Pattern Printing

- After the printing, you can see the following printed pattern.

**PF Pattern**

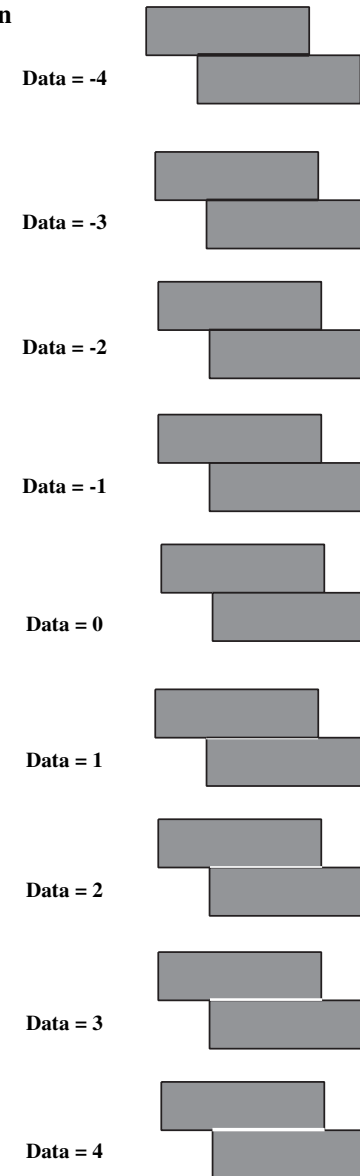

Figure 5-30. Screen Indication during PF Adjust Pattern Printing

6. A PF adjust pattern is made by 2 blocks. And you need to select most right one without white banding or black banding. Following is the printer condition for both white line and black banding. Among Figure 5-30 patterns, most right pattern is data "0", and you must input "0" in the following step.

**White Banding:** Overloading a paper.

**Black Banding:** Slipping the PF roller.

7. Select "Adjust", and press "O.K." button on the program screen. The program screen changes as follows.

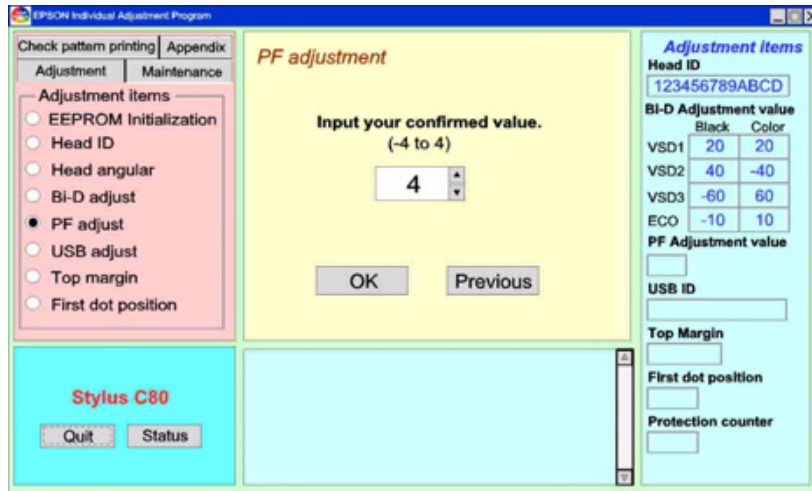

Figure 5-31. PF Adjustment Value Input Screen

8. By using up/down arrow key, change the present registered value to your actual confirmed value. (In case of Figure 5-30, change to "0", and press "O.K." button. Program screen changes as follows.

**NOTE:** "4" in the indicator is the actual readout value from the EEPROM. So, if you've replaced to new main board, you can see the default value ("0"), and in case if you perform the PF adjustment without main board replacement, you can see previous registered value.

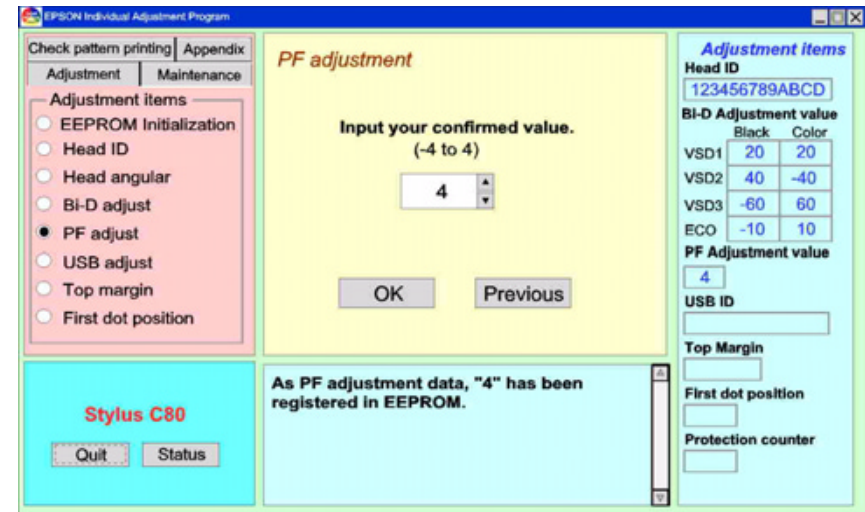

Figure 5-32. PF Adjustment Value Acceptance Screen

**NOTE:** Unlike Bi-D adjustment, you need not to recheck on the next printing pattern. Regardless of your input data, Figure 5-30 pattern will never be changed. (Fixed printing without offset.)

**NOTE:** If you do not understand which pattern is the most right pattern in Figure 5-30, you need to perform the head cleaning once to make the printer fire inks correctly.

**NOTE:** Unlike Bi-D adjustment, adjustable range is -4 to +4 only. And if cannot see good pattern in Figure 5-30, you need to recheck the part that you've disassembled/re-assembled whether all units are working correctly or not.

## 5.2.7 USB ID Readout (Checking)

This section describes how to readout/input the USB ID from/to the main board. This operation is required when you replace to new main board. But, there is a possibility that you cannot readout current USB ID caused by the physical damaging of the main board. In this case, you need to input the 10-digits serial number after you replace to new main board. Following is the judgement standard mentions how to treat USB ID.

### Case 1> Possible to readout the original USB ID

- Step 1. Readout original USB ID, and write-down it.  
(Using adjustment program.)
- Step 2. Replace to new main board.
- Step 3. Input original USB ID that you written-down in step 1.  
(Using adjustment program.)
- Step 4. Due to this, user needs not to reinstall the printer driver from the beginning.

### Case 2> Impossible to readout the original USB ID

- Step 1. Replace to new main board.
- Step 2. Input 10-digits serial number mentioned on the back of the main unit. (Using adjustment program.)
- Step 3. User needs to reinstall the printer driver after he/she receives the repaired unit that because USB information is in mismatching between user's PC and repaired unit. But, the serial number is the unique, and there is no anxiety that the multiple devices that have same USB ID conflicts each other.

**NOTE:** There are 18-digits in USB ID. But in case you input the 10-digits serial number, the adjustment program will automatically create original 18-digits USB ID.

### 5.2.7.1 Possible to Readout the Original USB ID (CASE 1)

1. Setup the adjustment program. Main screen (Figure 5-2) appears.  
(Refer to Section 5.2.1.)
2. Select "Adjustment" and then "USB ID".
3. Main screen changes as below.

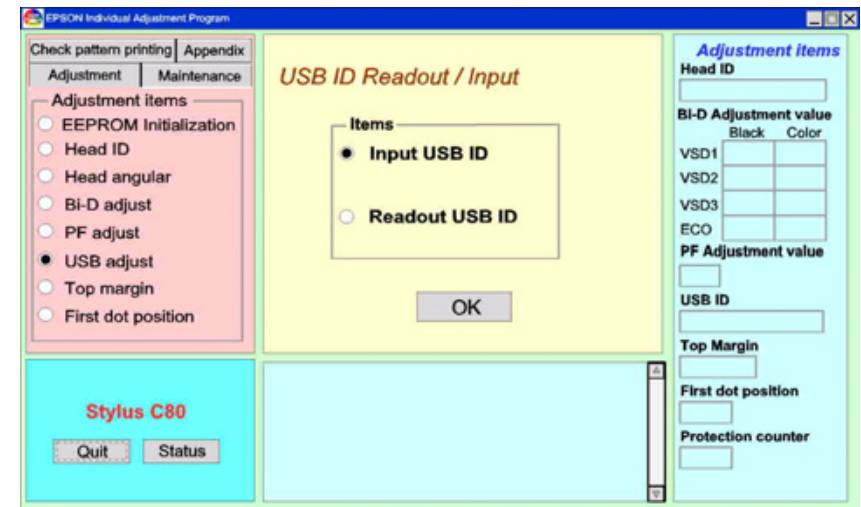

Figure 5-33. USB ID Readout/Input Initial Screen

4. Select "Readout USB ID", and press "O.K." button on the program screen.



5. Initial screen changes as below.

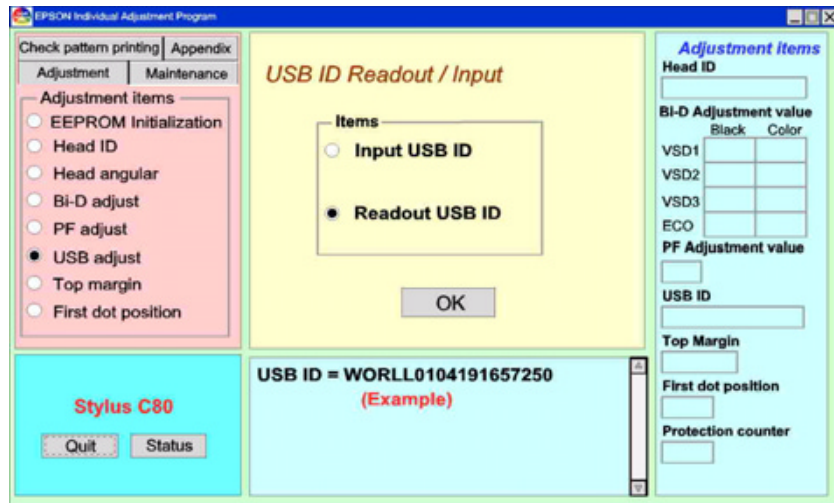

Figure 5-34. USB ID Readout Screen

6. Write-down the indicated USB ID, and once quit the adjustment program.
7. Replace to new main board.
8. Setup the adjustment program again. Main screen (Figure 5-2) appears. (Refer to Section 5.2.1.)
9. Select "Adjustment", and then "Input USBG ID". Then press "O.K." button on the program screen.

10. Following screen appears.

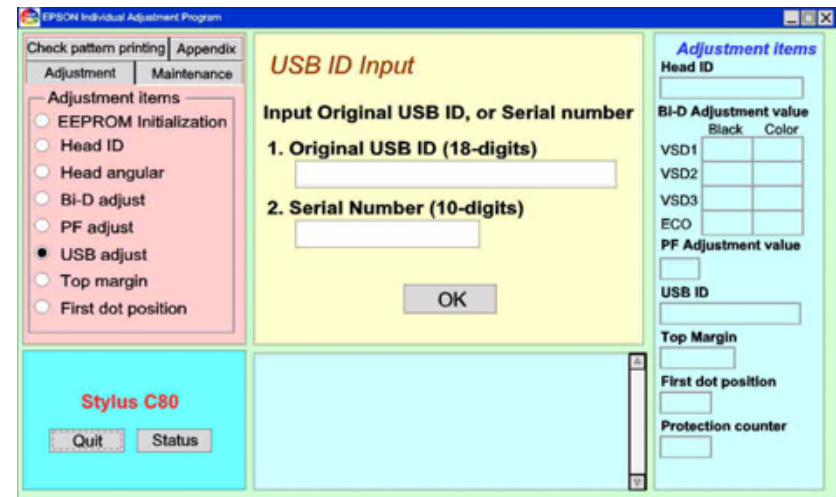

Figure 5-35. USB ID/Serial Number Input Mode

11. Input the original USB IDs that you wrote-down at step 6, then press "O.K." on the program screen.
12. Program screen changes as below.

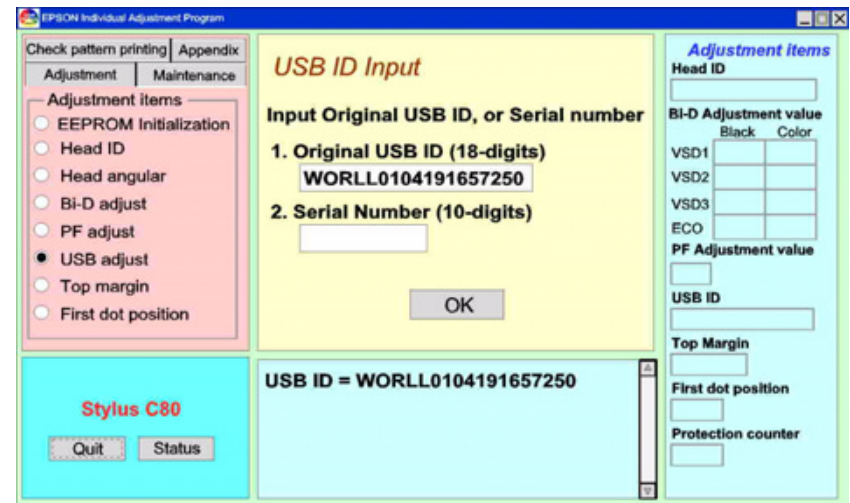

Figure 5-36. USB ID/Serial Number Input Mode 2



### 5.2.7.2 Impossible to Readout the Original USB ID (CASE 2)

1. Setup the adjustment program. Main screen (Figure 5-2) appears. (Refer to Section 5.2.1.)
2. Select "Adjustment" and then "USB ID". (Figure 5-33 screen appears.)
3. Select "Readout USB ID". (Figure 5-35 screen appears.)
4. See the 10-digits serial number that is mentioned on the serial ravel and memo it. Serial ravel location is on the back of the main unit.
5. Input 10-digits serial codes on the "2. Serial Number (10-digits)" window, then press "O.K." button on the program screen. Program screen changes as below.

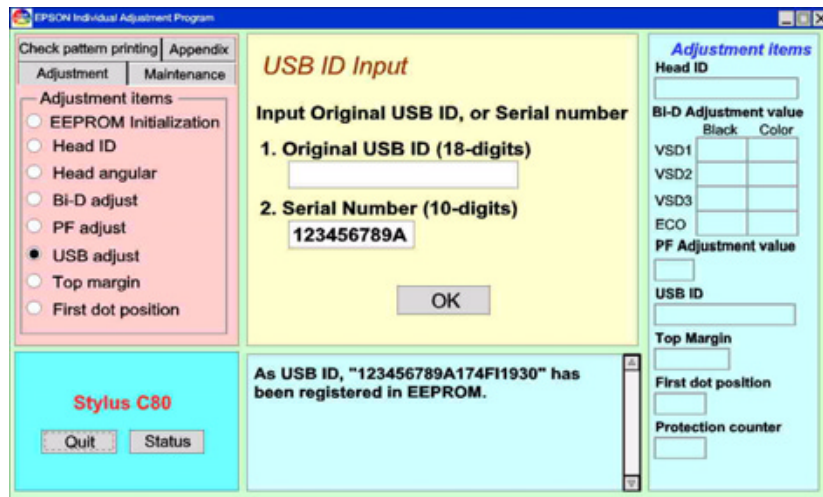

Figure 5-37. USB ID/Serial Number Input Mode 3

*NOTE: USB ID (18-digits) will be created depending on the serial number. Following is how to create 18 digits.*

**123456789A 174F1930**

**Serial Number      Year, Month, Date, Hour, Minutes, Second**

Figure 5-38. How to Create 18-digits USB ID Based on 10-Digits Serial Number

### 5.2.8 EEPROM Initialization

This section describes how to initialize the EEPROM, what kind of parameter will be initialized, and what's for. This operation must be made only when you replace to new main board.

*NOTE: Even though you perform the EEPROM initialization, it does not mean all parameters in EEPROM will be initialized, and USB ID that you registered in Section 5.2.7 will never be changed and cleared.*

- Purpose  
There are some important parameters in EEPROM and the firmware compares/ checks its data at power on timing. So, if the parameters have been changed caused by some unexpected causes, unexpected error indication may possibly be occurred. To prevent such this problem, the adjustment program has a function to overwrite the important factory setting parameters onto an each specific EEPROM address.
- What kind of parameter will be initialized by this operation  
Followings are the all items that EEPROM initialization supports.

**Table 5-2. All Contents of EEPROM Initialization**

No.	Items	Address	Initial Setting	After Initialize	Setting Contents	Purpose
1	CG Table	51H	00H	08H	PC 437	Previously, we input this value on the opening screen of the adjustment program.
2	Font	52H	00H	02H	Courier	
3	D4 for USB	65H	00H	01H	On	Since this setting is input on the assembling manufactory (not to set at main board vendor side), SEC should prepare this setting beforehand for the spare Main board.
4	CSIC Printer Name	0BH	00H	C80: 94H C70: 95H	<ul style="list-style-type: none"> <li>Common CSIC with C70</li> <li>Common CSIC with C80</li> </ul>	
5	Market ID	E1H	00H	00H	Standard	Previously, we input this value on the opening screen of the adjustment program.

1. Setup the adjustment program. Main screen (Figure 5-2) appears. (Refer to Section 5.2.1.)
2. Select "Adjustment" and then "EEPROM initialization".

3. Following screen appears.

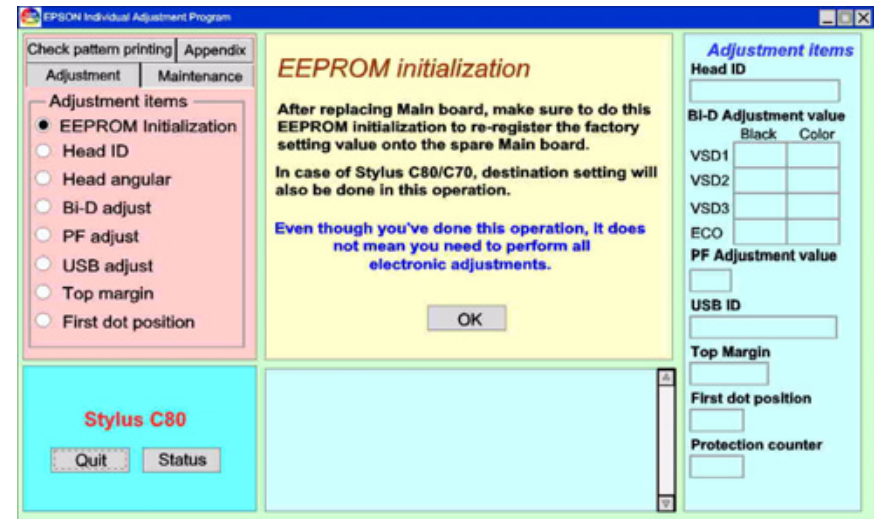

**Figure 5-39. EEPROM Initialization Initial Screen**

4. Press "O.K." button on the program screen. Then you can see following acceptance screen.

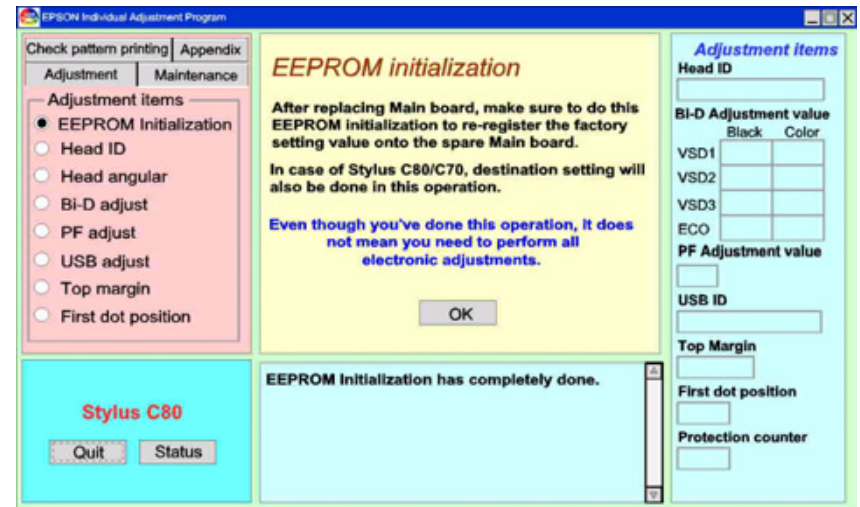

**Figure 5-40. EEPROM Initialization Completion Screen**

### 5.2.9 Platen Gap Adjustment (Mechanism Adjustment)

This section describes how to perform the platen gap adjustment. This adjustment must be made under the following conditions.

**NOTE:** This adjustment can not be made without removing upper case and middle case.

1. Carriage Guide shaft has been replaced or removed.
2. Lubrication has been done for the carriage guide shaft.

**NOTE:** Lubrication for the carriage guide shaft requires its removal once. And Do not lubricate the oil directory without removal. (Refer to Chapter 6 "Maintenance".)

3. Carriage unit has been replaced or removed.
4. Platen Gap adjust lever for the right side or the bushing for the left side has been moved.

1. Make sure check that AC cable disconnects to the printer.
2. Prepare the thickness gauge. (thickness = 1.35 mm)
3. Loosen a screw (C.B.S M3x6) securing the PG adjust lever.

**NOTE:** Do not remove a screw completely. (two or three revolution)

**NOTE:** You need not to loosen a screw securing PG adjust bushing on the left side.

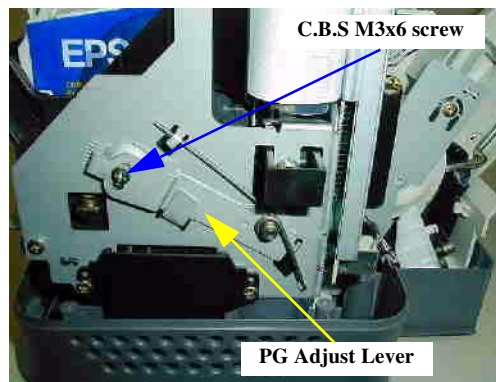

Figure 5-41. PG Adjust Lever Location

4. Release the carriage lock lever if the carriage is locked.

5. Place the thickness gauge around the right side of the front paper guide. (Specification: 1.35 mm)

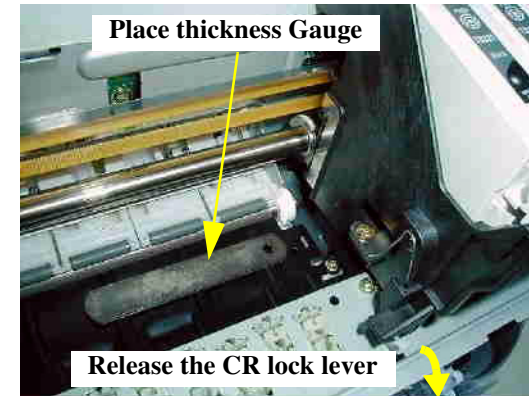

Figure 5-42. Thickness Gauge Placing

6. Check PG lever is normal position, and change to normal position if PG lever is in envelope position.
7. Move the carriage unit on the placed thickness gauge by using timing belt, and check whether the placed thickness gauge moves or not.

**NOTE:** If you push the carriage unit directly, print head surface is possible to be had a damaging caused by the friction with the thickness gauge.

**NOTE:** Following is the relationship between "PG adjust lever operation" and "platen gap reaction".

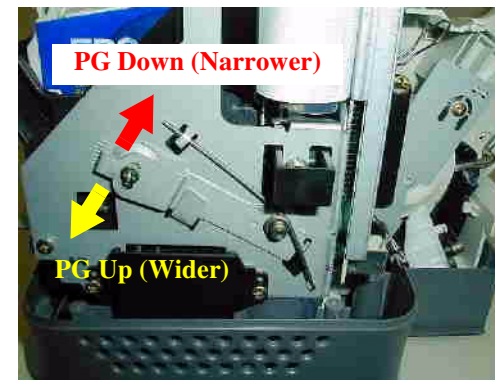

Figure 5-43. Relationship between Lever Operation & Platen Gap

8. Accede to following steps until you've completed the right side PG adjustment.

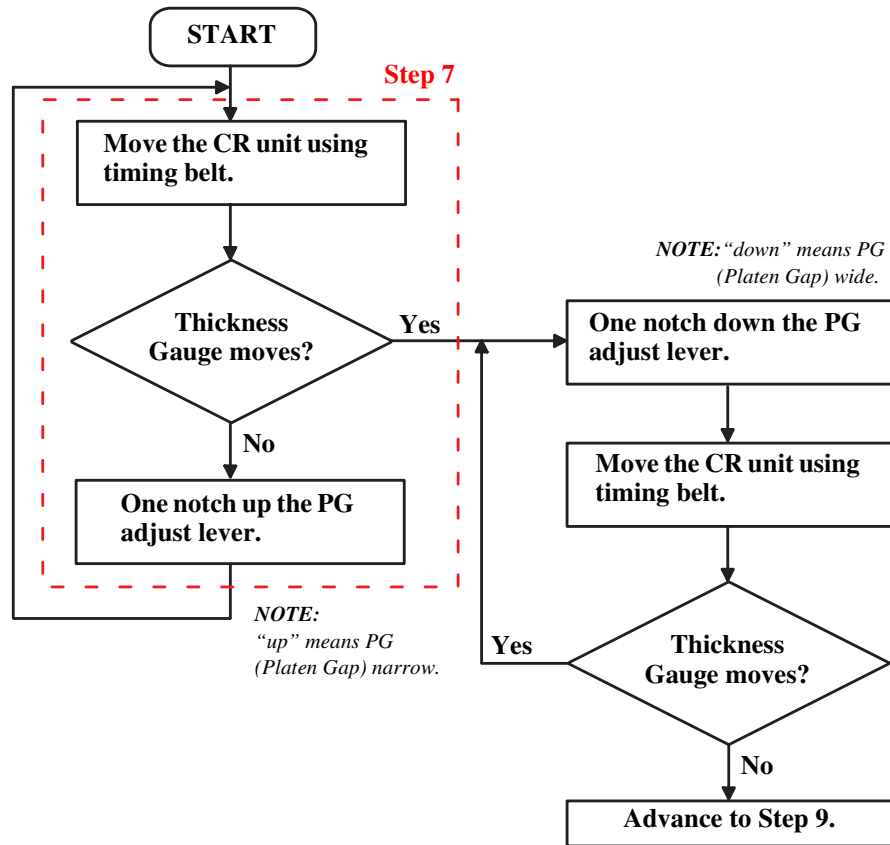

Figure 5-44. Right Side PG Adjustment

9. One notch down the PG adjust lever, and then tighten a screw securing PG adjust lever temporary.
10. Loosen a screw (C.B.S M3x6) securing the PG adjust bushing.

NOTE: Do not remove a screw completely. (two or three revolution)

NOTE: You need not to loosen a screw securing PG adjust lever on the right side.

NOTE: Before you advance to next operation for the left side PG adjustment, note that following is the relationship between "PG adjust bushing operation" and "platen gap reaction".

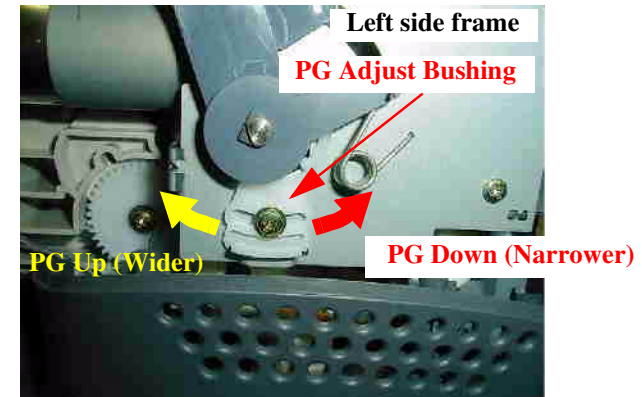

Figure 5-45. Left Side PG Adjustment

11. Place the thickness gauge around the left side of the front paper guide. (Specification: 1.35 mm)
12. Move the carriage unit on the placed thickness gauge by using timing belt, and check whether the placed thickness gauge moves or not.

NOTE: If you push the carriage unit directly, print head surface is possible to be had a damaging caused by the friction with the thickness gauge.

13. Accede to following steps until you've completed the left side PG adjustment.

16. Accede to following steps to check right side PG again.

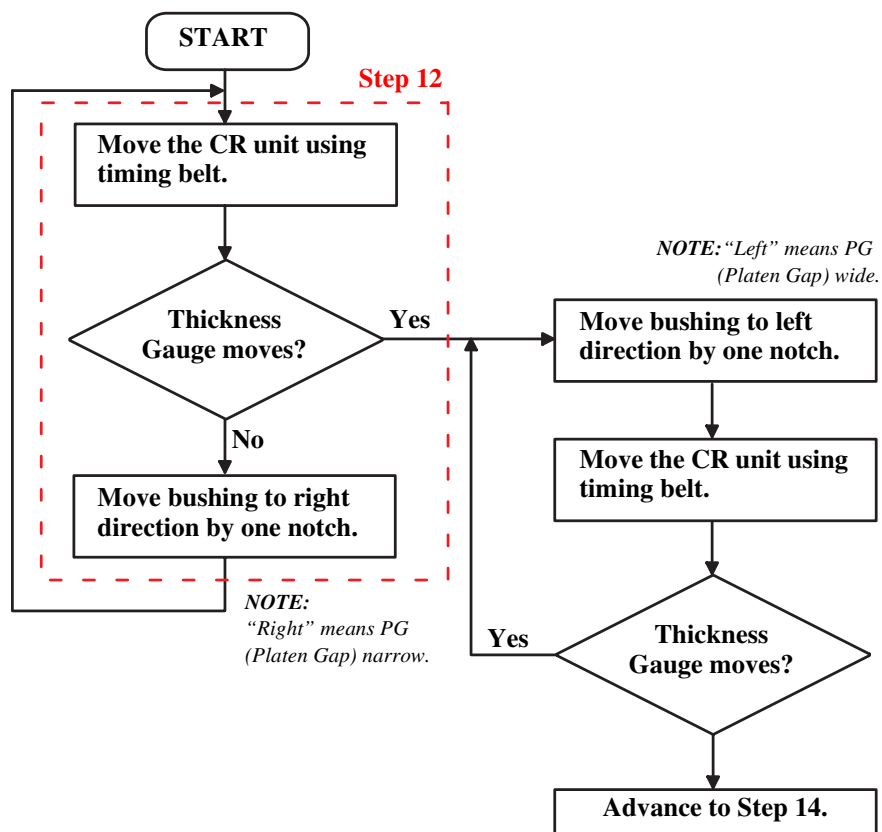

Figure 5-46. Left Side PG Adjustment

- 14. Shift one notch to left, and then tighten a screw securing PG adjust bushing temporary.
- 15. Place the thickness gauge around the right side of the front paper guide again. (Specification: 1.35 mm)

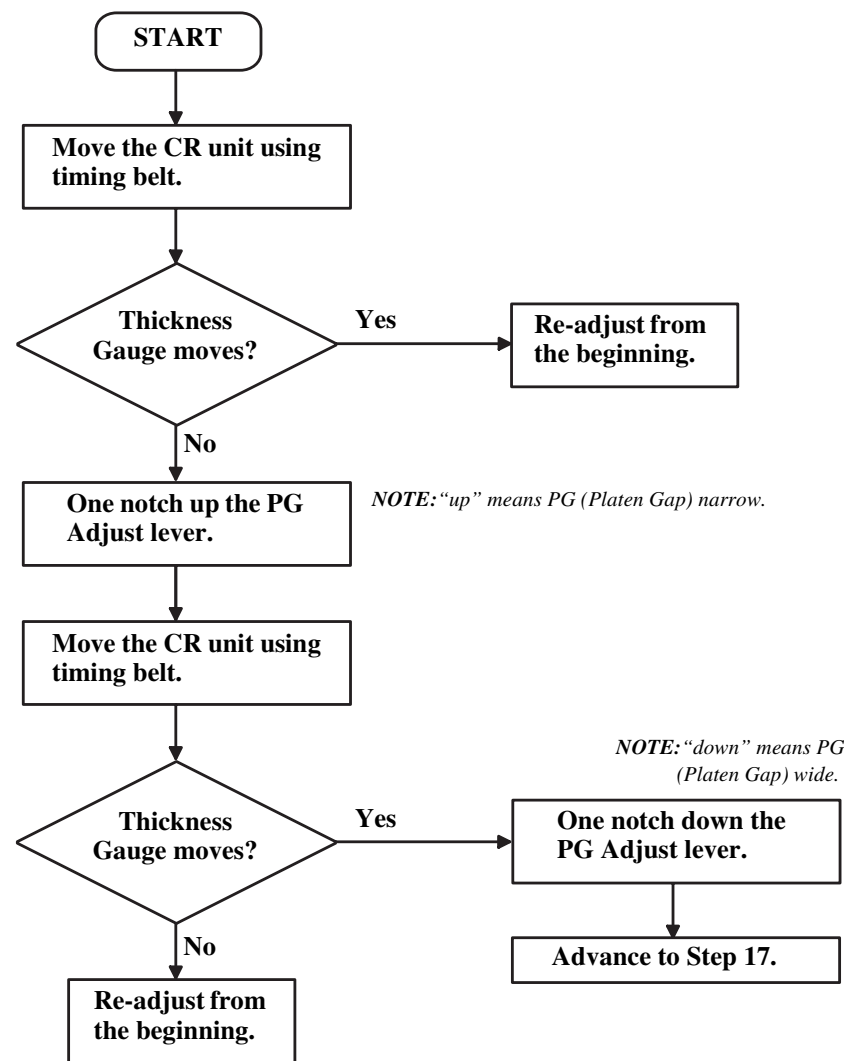

Figure 5-47. Right / Left Sides PG Checking

17. Tighten both screws completely.



### 5.2.10 Head Cleaning Operation

This section describes how to perform the cleaning that Stylus C70/C80 supports. The cleaning that the adjustment program supports is the powerful cleaning called CL3, and you can try recovering the clogged nozzle(s) efficiently.

**NOTE:** If you cannot recover clogged nozzle(s), advance to "Section 5.2.3" for the "ink charge" operation.

1. Setup the adjustment program. Main screen (Figure 5-2) appears. (Refer to Section 5.2.1.)
2. Select "Maintenance" and then "Head cleaning".
3. Main screen changes as below.

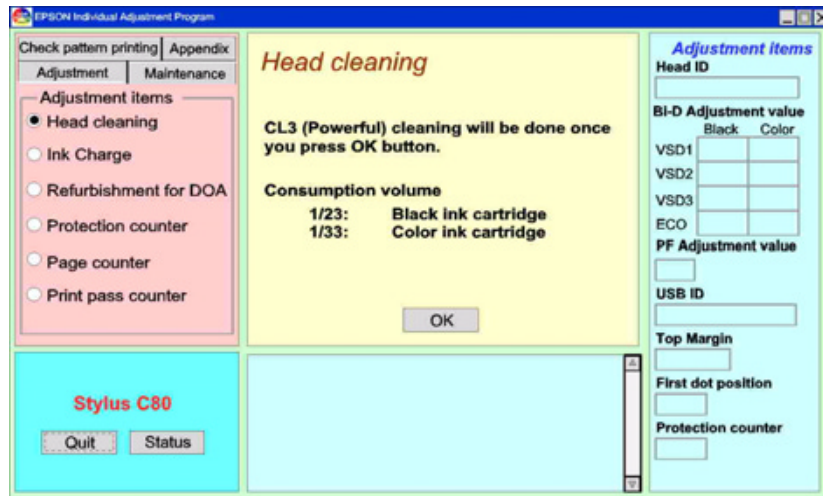

Figure 5-48. Head Cleaning Initial Screen

4. Press "O.K." button on the program screen.

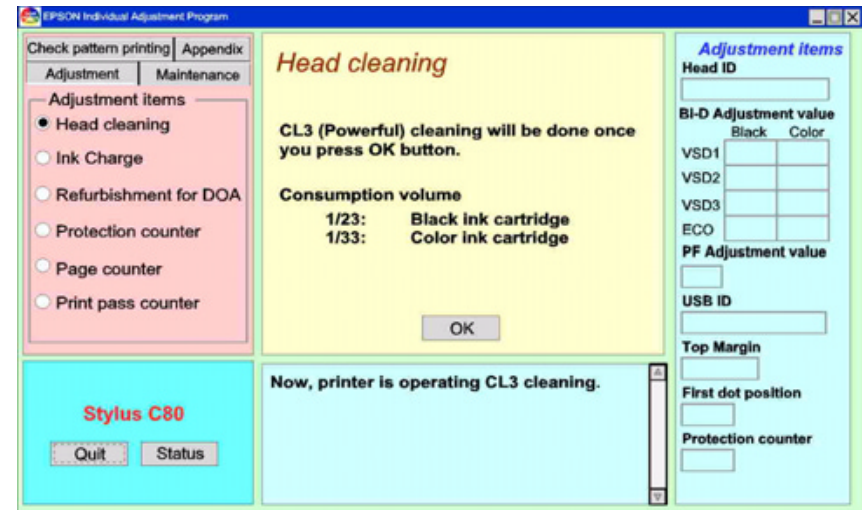

Figure 5-49. Head Cleaning Completion Screen

5. Recheck the printing result, and perform the head cleaning again if there is (a) some clogged nozzles on the printed paper.



### 5.2.11 Protection Counter Clear (and Check)

This section describes how to clear the protection counter. This operation must be done under the following conditions.

1. When replacing waste ink drain pad.
  2. When user carries on the unit that has been occurred the maintenance error.
  3. Refurbishment
1. Replace to new waste ink drain pad by referring Chap 4 "Disassembly & Re-assembly".
  2. Setup the adjustment program. Main screen (Figure 5-2) appears. (Refer to Section 5.2.1.)
  3. Select "Maintenance" and then "protection counter".
  4. Main screen changes as below.

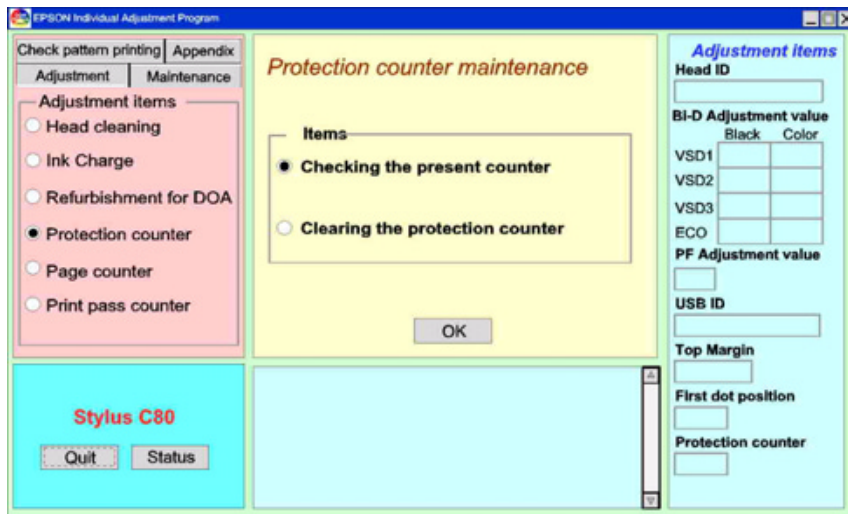

Figure 5-50. Protection Counter Operation Initial Screen

5. Select "Clearing the protection counter", and press "O.K." button on the program screen.

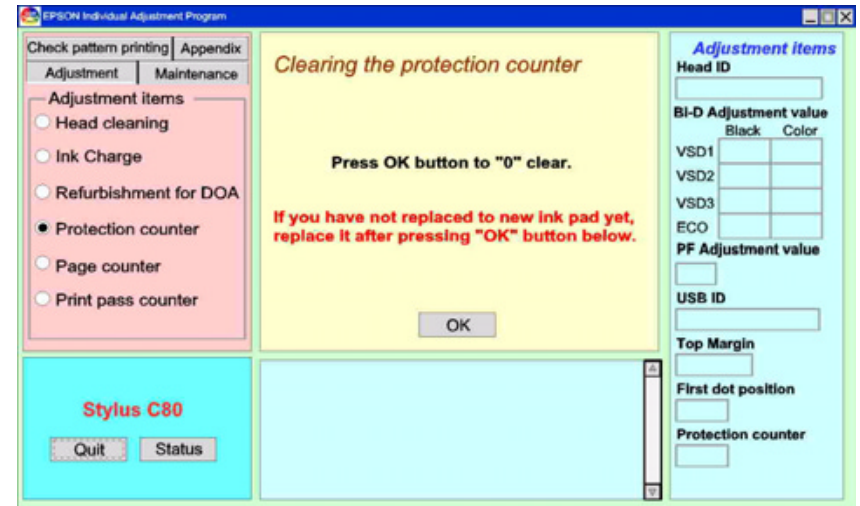

Figure 5-51. Protection Counter Clearing Screen

6. Press "O.K." button on the program screen.
7. Following screen appears.

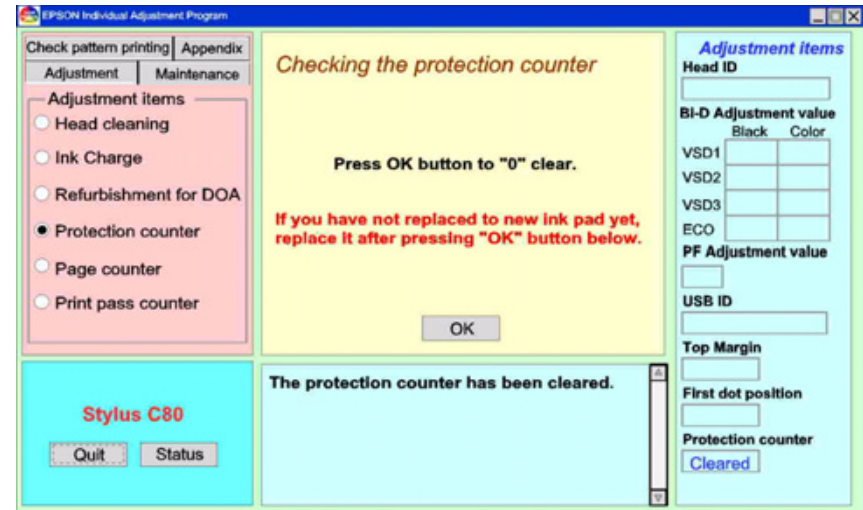

Figure 5-52. Protection Counter Clear Completion Screen

*NOTE: If you want to check the current protection counter, accede to following steps.*

8. On the Figure 5-50 screen, select "Checking the present protection counter", and press "O.K." button on the program screen.
9. Following screen appears.

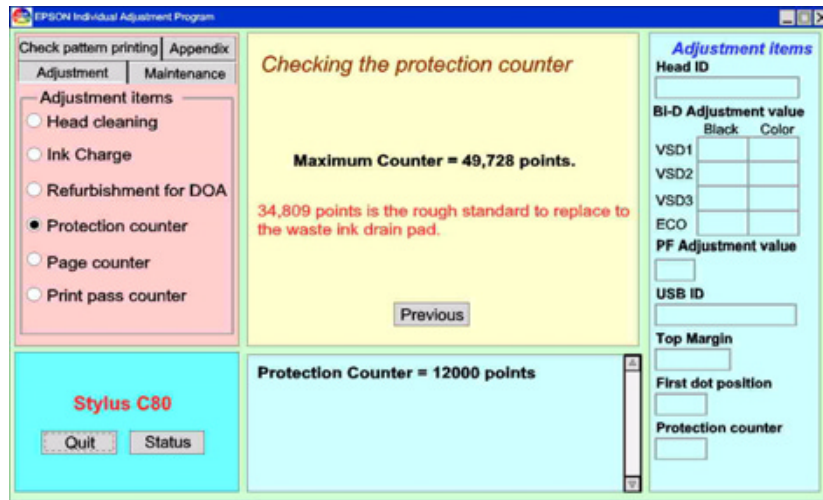

Figure 5-53. Protection Counter Check Screen

### 5.2.12 Top Margin Adjustment

This section describes how to adjust the TOP margin. Basically, top margin adjustment is not required to your usual repair activity. But sometimes, a specific user requires you to do the fine-adjustment for the TOF (Top of Form) position.

*NOTE: The adjustable range is from -2 mm to +2 mm for both Stylus C70 and C80 printers.*

1. Setup the adjustment program. Main screen (Figure 5-2) appears. (Refer to Section 5.2.1.)
2. Select "Adjustment" and then "Top margin".
3. Main screen changes as below.

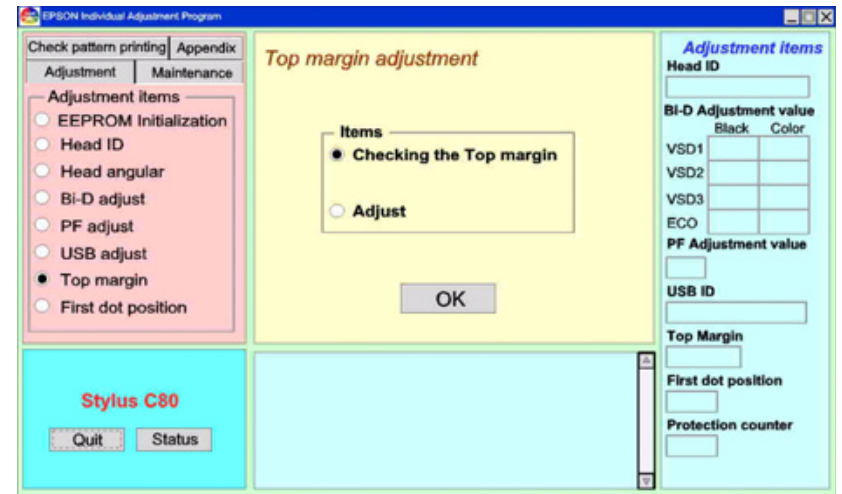

Figure 5-54. Top Margin Adjustment Initial Screen

4. Select "Checking the Top margin", and press "O.K." button on the program screen. Printer starts printing a top margin line printing. Following screen appears.

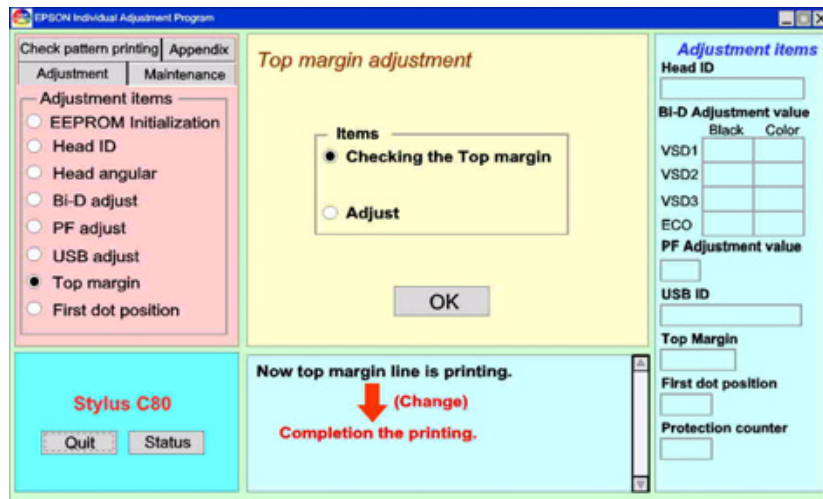

Figure 5-55. Top Margin Line Printing Screen

5. And following is the printed pattern.

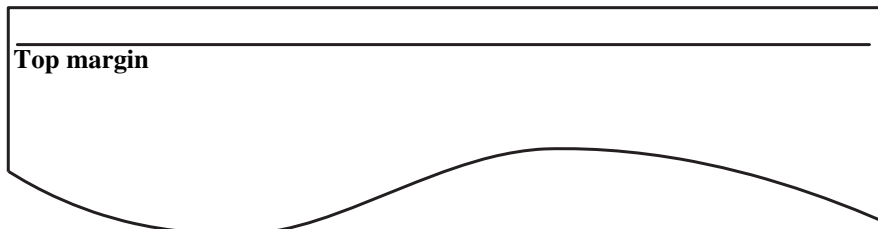

Figure 5-56. Top Margin Line Printing Pattern

6. Check the current top margin between printed line and paper top edge using a measure. And decide your target adjust value. (ex. -1 mm or +2 mm.)

7. Select "Adjust", and press "O.K." button. Following screen appears.

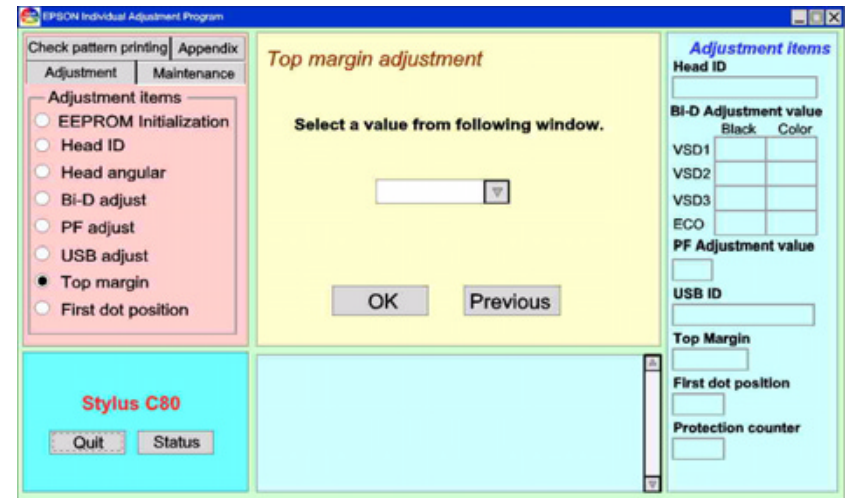

Figure 5-57. Top Margin Adjustment Initial Screen

8. Select under row. Following screen appears.

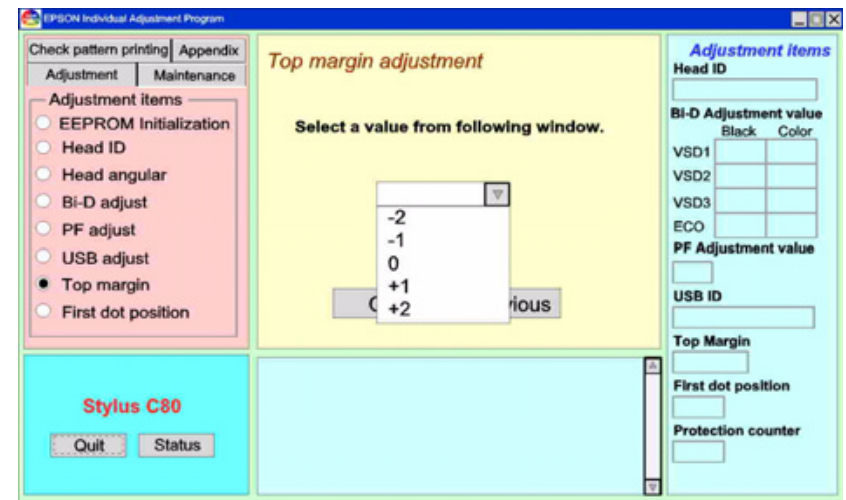

Figure 5-58. Adjustment Value Selection Screen

9. Select your decided value at step 6, and then press "O.K." button on the program screen. You can see following screen.

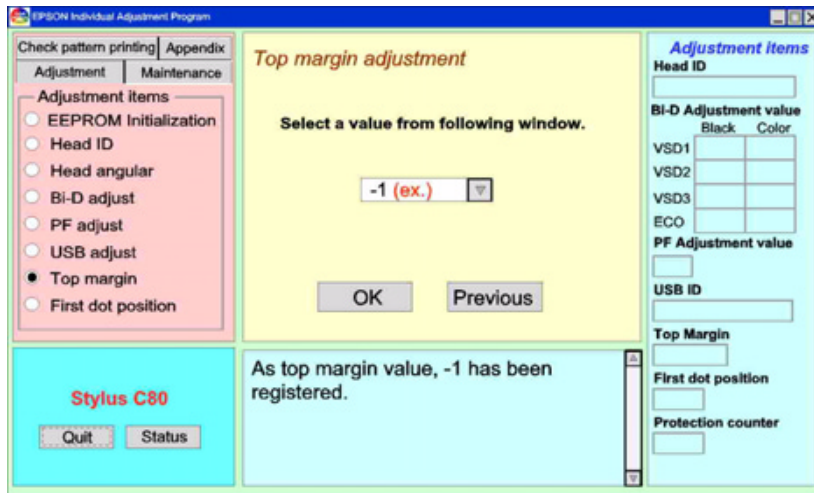

Figure 5-59. Adjustment Value Input Screen

10. Press "Previous" button on the program screen. The program screen returns to Figure 5-54 status.
11. Press "Checking the Top margin", and press "O.K." button on the program screen. Printer starts printing a top margin line printing again with adjusted value.
12. Check the printing whether your target line prints or not.
13. If you judge the re-adjustment is necessary, repeat step 5 to step 11 until you judge the adjustment has completed.

### 5.2.13 First Dot Position Adjustment

*NOTE:* Functions not included in the specification have been removed from Rev. B.

This section describes how to adjust the first dot position adjustment. Basically, this adjustment is not required to your usual repair activity. But sometimes, a specific user requires you to do the fine-adjustment for the first dot position.

*NOTE:* The adjustable range is from -2 mm to +2 mm for both Stylus C70 and C80 printers.

*NOTE:* Before adjusting this, completes top margin adjustment to adjust/fix the first dot position.

*NOTE:* This adjustment allows you to change the first dot position by 1 step only. (+/-1.0583 mm)

1. Setup the adjustment program. Main screen (Figure 5-2) appears. (Refer to Section 5.2.1.)
2. Select "Adjustment" and then "First dot position".
3. Main screen changes as below.

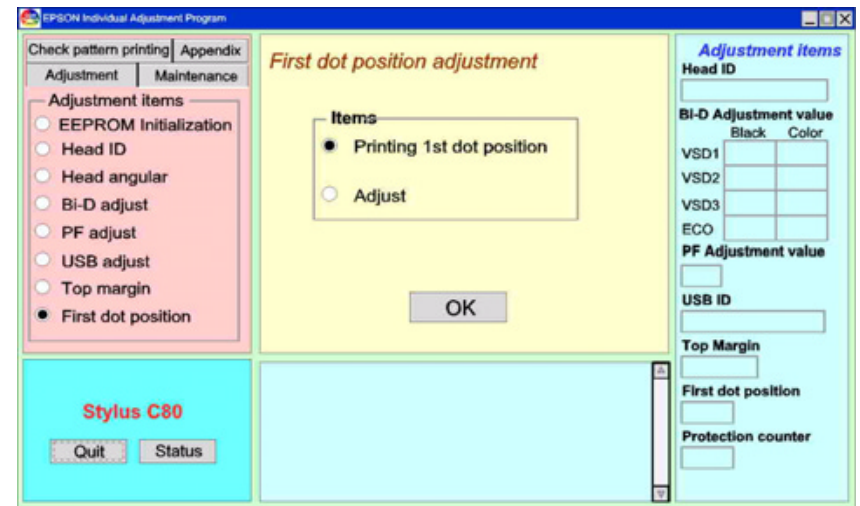

Figure 5-60. 1<sup>st</sup> Dot Position Adjustment Initial Screen



4. Select "Printing 1<sup>st</sup> dot position", and press "O.K." button on the program screen. Printer starts printing a 1<sup>st</sup> dot position printing. Following screen appears during printing.

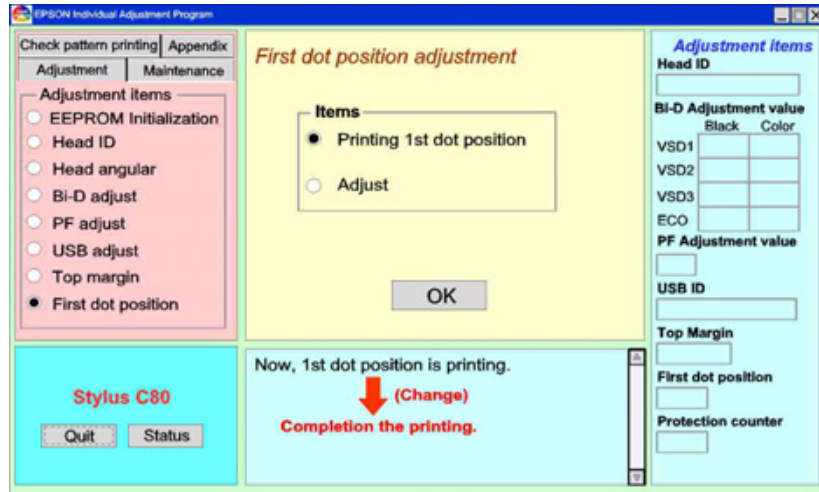

Figure 5-61. 1<sup>st</sup> Dot Position Printing Screen

5. Following is the printed pattern. And check your expected direction either right or left.

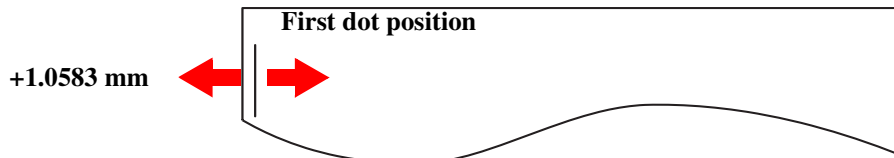

Figure 5-62. 1<sup>st</sup> Dot printing Pattern

6. Select "Adjust" and press "O.K." button on the program screen.

7. Following screen appears.

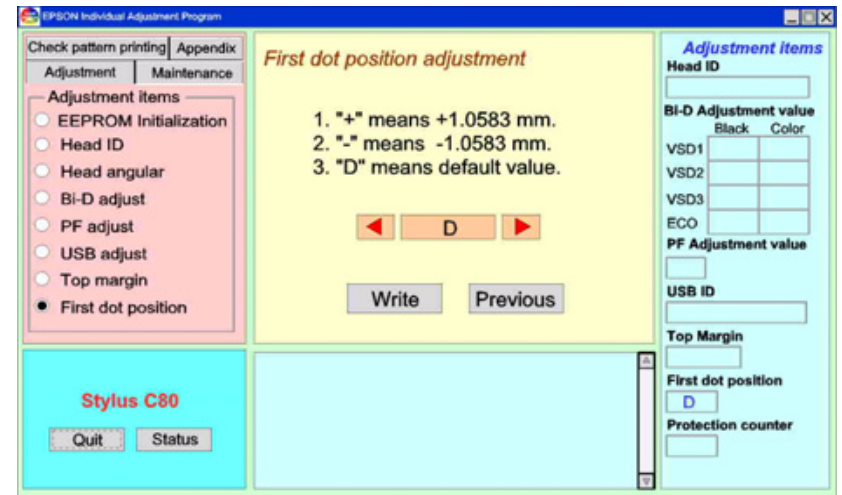

Figure 5-63. 1<sup>st</sup> Dot Position Adjustment Screen

8. Using right/left key, select out your expected value, then press "Write" button on the program screen.
9. Program screen changes as below.

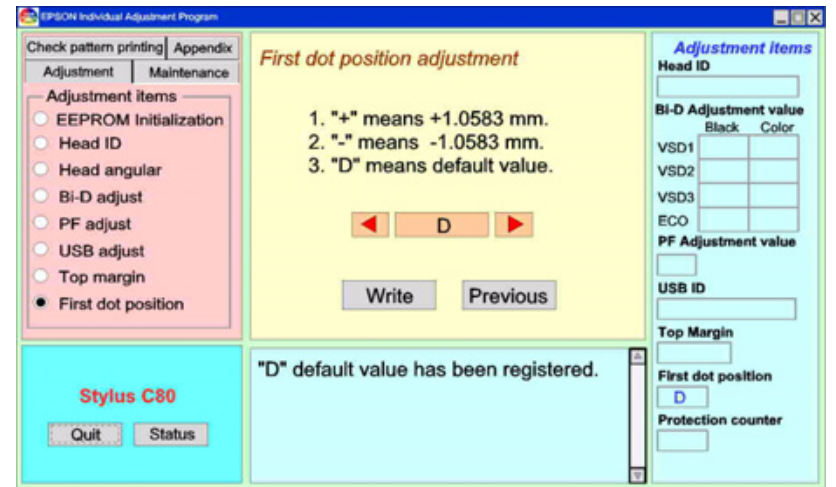

Figure 5-64. Input Value Acceptance Screen

10. Press "Previous" button to return the program screen to the initial screen as mentioned Figure 5-60.
11. Select "Printing 1<sup>st</sup> dot position", and press "O.K." button on the program screen.
12. Check your target position achieves or not.

**NOTE:** Since the adjustable range is very small for the 1st dot position adjustment, this program supports 3 steps (plus, minus, and default value) only. Following is the outline about this adjustment.



**Figure 5-65. Outline of 1<sup>st</sup> Dot Position Adjustment**



CHAPTER

6

**MAINTENANCE**

## 6.1 Overview

---

This section provides information to maintain the printer in its optimum condition.

### 6.1.1 Cleaning

This printer has no mechanical components which require regular cleaning except the printhead. Therefore, when returning the printer to the user, check the following parts and perform appropriate cleaning if stain is noticeable.



- **Never use chemical solvents, such as thinner, benzine, and acetone to clean the exterior parts of printer like the housing. These chemicals may deform or deteriorate the components of the printer.**
- **Be careful not to damage any components when you clean inside the printer.**
- **Do not scratch the surface (coated part) of PF roller assembly. Use soft brush to wipe off any dusts. Use a soft cloth moistened with alcohol to remove the ink stain.**
- **Do not use cleaning sheet included in the media for normal usage. It may damage the coated surface of PF roller. If the adhesive surface of the cleaning sheet is set to the ASF LD roller side and used to clean the ASF LD roller surface, it is no problem.**

- Exterior parts  
Use a clean soft cloth moistened with water and wipe off any dirt. If the exterior parts are stained with ink, use a cloth moistened with neutral detergent to wipe it off.
- Inside the printer  
Use a vacuum cleaner to remove any paper dust.
- ASF LD Roller  
If paper dust on the surface of ASF LD Roller lowers the friction, set the adhesive surface of the cleaning sheet included in the media to the surface of the ASF roller and repeat loading paper from the ASF.

## 6.1.2 Service Maintenance

If print irregularity (missing dot, white line, etc.) has occurred or the printer indicates “Maintenance Error”, take the following actions to clear the error.

### □ **Head Cleaning:**

The printer has a built-in head cleaning function, which is activated by operating the control panel.

Confirm that the printer is in stand-by state (the POWER indicator is not blinking), and hold down the Error Reset SW on the control panel for more than 3 seconds. The printer starts the cleaning sequence (The POWER indicator blinks during the cleaning sequence).

### □ **Maintenance Error Clear:**

Ink is used for the operations such as cleaning as well as printing. Therefore, the printer wastes certain amount of ink and drains it into waste ink pad, while counting the amount of the waste ink. Once the amount of the waste ink reaches the predetermined limit, the printer indicates “Maintenance Error” and the waste ink pad should be replaced.

#### ■ **Overflow Counter Limit:**

Overflow Counter (Protection Counter A)  $\geq$  49728

#### ■ **Timing for Replacing the Waste Ink Pad:**

When the total amount of the waste ink reaches the predetermined limit, the LED indicates “Maintenance Error”. (Refer to Section 1.5.4 “Printer Conditions and Panel Status”. Also, troubleshooting “chap 3” mentions more detail.)

Also, during repair servicing, check the ink counter along with the firmware version, ink counter, select code page, nozzle check pattern on the status printing sheet. If the ink counter value is close to its limit, notify your customer and recommend that the waste ink pad be replaced (If the waste ink pad is not replaced at that time, there is a possibility that “Maintenance Error” will occur soon after the printer is returned to the customer). Once you have the confirmation of the customer, replace the waste ink pad.

#### ■ **Replacement Procedure: Refer to Section 4.2.6.**

#### ■ **After the Replacement:**

Reset the Overflow Counter (Protection Counter A):  
(Stylus C70)

Power on printer with Load/Eject SW and Cleaning SW are pushed, and push Cleaning SW within error indicator is blinking (10 seconds).  
(Stylus C80)

Power on printer with Power SW and Ink SW are pushed, and push Ink SW within error indicator is blinking (10 seconds).

Refer to Section 1.4.3 “Panel Function” for details.

### 6.1.3 Lubrication and Adhesion

The types lubricants used in the Stylus Color C70/C80 are specified by SEIKO EPSON. Lubricate the printer if necessary under the following conditions;

- Oil has been wiped off during cleaning.
- Printer has been disassembled/assembled.
- Specific part(s) in the printer has been replaced.

For a specific feature of ink jet printers, an oil pad(s) must be lubricated with a special care. Observe the instructions below and perform lubrication by strictly following the specified lubricants type, amount, and the way to apply.

**CAUTION**

- **Never add oil to the currently used oil pad. Be sure to supply specified amount of oil will be absorbed, which damages the print head.**
- **Pay special attention in handling "O-12" so the print head is not smeared with it.**
- **Never apply oil directly to the carriage shaft guide. Be sure to remove the print head unit and the carriage unit before replacing the current oil pad with a new one and then supplying oil to the new pad.**  
Accordingly, you need to perform any necessary head related adjustment. (Refer to Chapter 5.)

**CAUTION**

- **When installing the carriage guide shaft after oiling the oil pad, be sure to clean the shaft and perform the preliminary lubrication before installing the shaft as described below:**
1. Using a dry cotton cloth, wipe off the oil on the carriage guide shaft surface well to remove dirt completely.
  2. Using the dry cotton cloth, clean the inner surfaces of the metallic bushings on the carriage unit through which the shaft is inserted. (To remove iron pieces)
  3. Get a new oil pad and supply "O-12" (0.5 cc) into it.
  4. Using the oiled side of the pad, lubricate over the whole surface of the carriage guide shaft well.
  5. Install another new oil pad to the specified position at the back of the carriage.
  6. Supply specified amount of "O-12" to the installed oil pad and oil pad rings.  
 Oil pad: 0.49 cc to 0.53 cc  
 Oil pad rings (2 points): each 0.13 cc to 0.16 cc  
 Make sure the printhead has been removed for this operation.

**NOTE 1:** For precise oil control, use the smallest-diameter syringe available. Also, never use the syringe without a needle on it.

**NOTE 2:** At this time, oil must be applied to the two oil pad rings as well as to the oil pad.

### 6.1.4 Lubrication the Carriage Guide Shaft

This section includes the procedure for lubricating the carriage guide shaft. Unlike other models, the lubrication of the carriage guide shaft is performed under many restrictions. Therefore, be sure to observe the CAUTION in the previous section and perform lubrication by strictly following the steps specified.

1. Remove the printhead. (Refer to 4.2.5)
2. Remove the carriage unit. (Refer to 4.2.6)
3. Clean the carriage shaft by wiping the shaft's surface with a dry cloth.

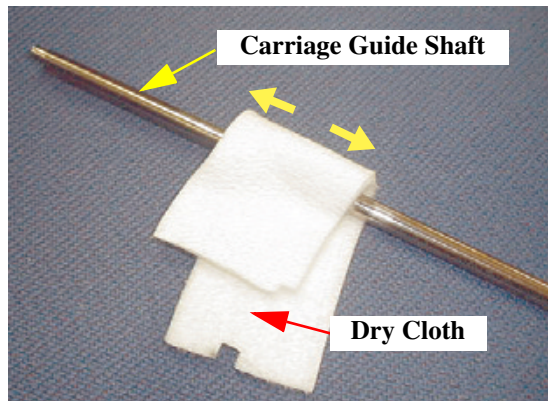

Figure 6-1. Cleaning the Carriage Guide Shaft

4. Remove the Oil Pad (a felt pad) from the back of the carriage unit.  
*NOTE: Do not re-use once removed pad.*
5. Remove 2 springs securing sub-oil pads, and remove 2 sub-oil pad.  
*NOTE: Do not re-use once removed sub-oil-pads.*

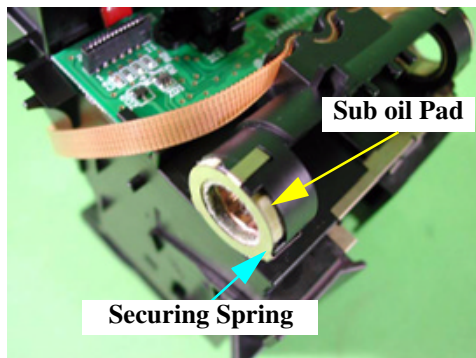

Figure 6-2. Oil Pads and fixing brackets

6. Using the dry cloth, completely wipe the inner surfaces of the 2 metallic bushings through which the carriage guide shaft is set. Especially, wipe well off black stains if any. Also, clean the portion where the pad was attached using the cloth.

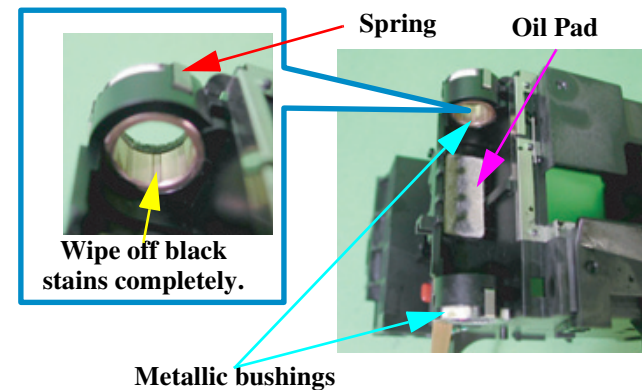

Figure 6-3. Locations for Oil Pad and Bushings

7. Get a smallest-diameter syringe available. The small syringe shown below only contains 2 cc maximally.



Figure 6-4. Small Syringe



Be sure to use a small-diameter syringe to minimize the tolerance. Small syringe allows you to see pushed amount (stroke) more clearly.

8. Get 2 new oil pads, and 2 new "sub oil pads".
9. To one of the new oil pads, supply "O-12" (0.5 cc) using the small syringe.



Supply "O-12" (0.5 CC) to the oil pad.

**Figure 6-5. Supplying Oil to the Oil Pad (1)**

10. Using the oiled side of the pad (step 8), lubricate the carriage guide shaft surface thoroughly.

Oil Pad already oiled with "O-12" (0.5 CC)

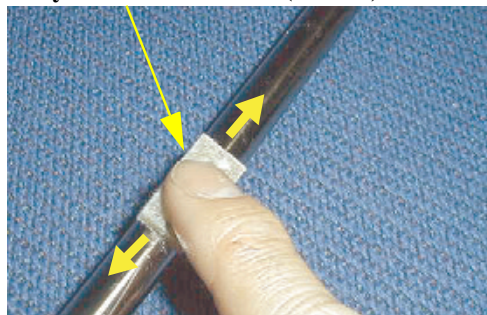

**Figure 6-6. Preliminary Lubrication with "O-12"**

11. Install the other new oil pad to the specified position at the back of the carriage.
12. Install new sub oil pads to both bushing of the carriage, and re-attach 2 springs to secure 2 sub oil pads.

13. Using the same syringe used in Step 9, supply "O-12" (0.49 - 0.53 cc) to the installed oil pad.

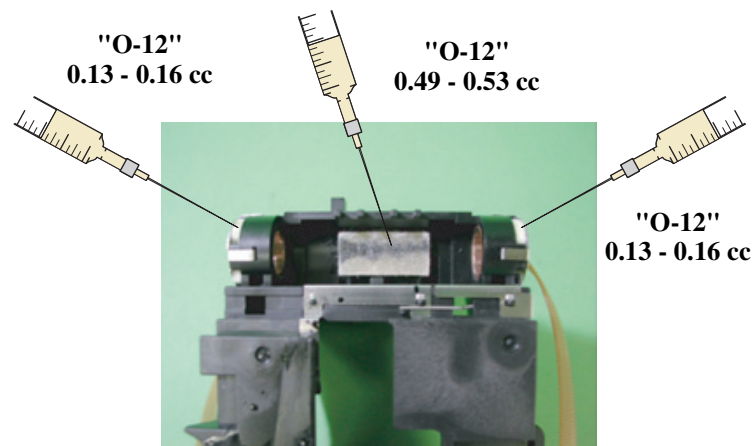

**Figure 6-7. Supplying Oil to the Oil Pad (2)**

14. Using the same syringe used in step 9, supply "O-12" (0.13 cc to 0.16 cc) to both new sub oil pads.
15. Install the carriage guide shaft to the carriage unit then to the printer main body. (See Chapter 4 / Section 4.2.6)
16. Install the printhead. (See Chapter 4 / Section 4.2.5)
17. Perform Paper Gap Adjustment. (See Chapter 5 / Section 5.2.9)
18. Turn the printer on without the ink cartridges installed to cause the Ink Cartridge Out Error.
19. Using the Load/Eject button, run the Ink Cartridge Replacement Sequence and install new ink cartridges.
20. Using the service program, perform Initial Ink Charge. (See Chapter 5 / Section 5.2.3)
21. Perform Head Angular Adjustment. (See Chapter 5 / Section 5.2.4)
22. Perform Bi-Directional Adjustment. (See Chapter 5 / Section 5.2.5)
23. Perform PF Adjustment. (See Chapter 5 / Section 5.2.6)



Table 6-1. Oil Applied to the Stylus Color C70/C80

Type	Name	EPSON Code	Supplier
Grease	G-26	B702600001	EPSON
Oil	O-12	1038991	EPSON

**NOTE:** No adhesion is used in the Stylus Color C70/C80.

Table 6-2. Lubrication Points Using "O-12"

No.	Lubrication Type/Point	Remarks
1	<p>&lt;Lubrication Point&gt;                      Apply oil to the Oil Pad.                      Refer to Figure 6-1 to 6-6.</p> <p>&lt;Lubrication Type&gt;                      O-12</p> <p>&lt;Lubrication Amount&gt;</p> <ul style="list-style-type: none"> <li>For a main oil pad. 0.49 cc to 0.53 cc</li> <li>For 2 sub oil pads. 0.13 cc to 0.16 cc</li> </ul>	<ul style="list-style-type: none"> <li>For details, refer to Section 6.1.4.</li> </ul>

Table 6-3. Lubrication Points Using G-26

No.	Lubrication Type/Point	Remarks
1	<p>&lt;Lubrication Point&gt;</p> <ul style="list-style-type: none"> <li>The surface of CR Guide Plate. Refer to Figure 6-8, "Lubrication point 1".</li> </ul> <p>&lt;Lubrication Type&gt;</p> <ul style="list-style-type: none"> <li>G-26</li> </ul> <p>&lt;Lubrication Amount&gt;</p> <ul style="list-style-type: none"> <li>Φ4mm sphere</li> </ul>	<ul style="list-style-type: none"> <li>Use a brush to apply it.</li> </ul>
2	<p>&lt;Lubrication Point&gt;</p> <ul style="list-style-type: none"> <li>The right end of PF Roller unit on metal surface a circle. Refer to Figure 6-9, "Lubrication point 2".</li> </ul> <p>&lt;Lubrication Type&gt;</p> <ul style="list-style-type: none"> <li>G-26</li> </ul> <p>&lt;Lubrication Amount&gt;</p> <ul style="list-style-type: none"> <li>3mm sphere</li> </ul>	<ul style="list-style-type: none"> <li>Do not attach the grease to the paper path.</li> <li>Be carefully not lubricate on coated surface.</li> <li>Do not touch coated surface of PF Roller.</li> <li>Use a brush to apply it.</li> </ul>
3	<p>&lt;Lubrication Point&gt;</p> <ul style="list-style-type: none"> <li>PF Roller along the PF Grounding Spring. Refer to Figure 6-10, "Lubrication point 3".</li> </ul> <p>&lt;Lubrication Type&gt;</p> <ul style="list-style-type: none"> <li>G-26</li> </ul> <p>&lt;Lubrication Amount&gt;</p> <ul style="list-style-type: none"> <li>4mm</li> </ul>	<ul style="list-style-type: none"> <li>Use an injector to apply it.</li> <li>Lubrication must be along PF Grounding Spring.</li> </ul>
4	<p>&lt;Lubrication Point&gt;</p> <ul style="list-style-type: none"> <li>The left of EJ Unit Roller a circle near the gear. Refer to Figure 6-11, "Lubrication point 4".</li> </ul> <p>&lt;Lubrication Type&gt;</p> <ul style="list-style-type: none"> <li>G-26</li> </ul> <p>&lt;Lubrication Amount&gt;</p> <ul style="list-style-type: none"> <li>3mm sphere</li> </ul>	<ul style="list-style-type: none"> <li>Use a brush to apply it.</li> </ul>

No.	Lubrication Type/Point	Remarks
5	<p>&lt;Lubrication Point&gt;</p> <ul style="list-style-type: none"> <li>EJ Unit Roller along the EJ Grounding Spring. Refer to Figure 6-12, "Lubrication point 5".</li> </ul> <p>&lt;Lubrication Type&gt;</p> <ul style="list-style-type: none"> <li>G-26</li> </ul> <p>&lt;Lubrication Amount&gt;</p> <ul style="list-style-type: none"> <li>4mm</li> </ul>	<ul style="list-style-type: none"> <li>Use a injector to apply it.</li> <li>Lubrication must be along EJ Grounding Spring.</li> </ul>
6	<p>&lt;Lubrication Point&gt;</p> <ul style="list-style-type: none"> <li>The inner of EJ Roller Holder Assy along the axes direction. Refer to Figure 6-13, "Lubrication point 6"</li> </ul> <p>&lt;Lubrication Type&gt;</p> <ul style="list-style-type: none"> <li>G-26</li> </ul> <p>&lt;Lubrication Amount&gt;</p> <ul style="list-style-type: none"> <li>The whole length</li> </ul>	<ul style="list-style-type: none"> <li>Use a injector to apply it.</li> </ul>
7	<p>&lt;Lubrication Point&gt;</p> <ul style="list-style-type: none"> <li>The 3 shafts of PF Frame Assy on outside end. Refer to Figure 6-14, "Lubrication point 7".</li> </ul> <p>&lt;Lubrication Type&gt;</p> <ul style="list-style-type: none"> <li>G-26</li> </ul> <p>&lt;Lubrication Amount&gt;</p> <ul style="list-style-type: none"> <li>Whole shaft length</li> </ul>	<ul style="list-style-type: none"> <li>Use a brush to apply it.</li> </ul>
8	<p>&lt;Lubrication Point&gt;</p> <ul style="list-style-type: none"> <li>To LD Rolled Shaft like (Figure 5). Refer to Figure 6-15, "Lubrication point 8".</li> </ul> <p>&lt;Lubrication Type&gt;</p> <ul style="list-style-type: none"> <li>G-26</li> </ul> <p>&lt;Lubrication Amount&gt;</p> <ul style="list-style-type: none"> <li>Whole circle about 4mm width</li> </ul>	<ul style="list-style-type: none"> <li>Use a brush to apply it.</li> </ul>

No.	Lubrication Type/Point	Remarks
9	<p>&lt;Lubrication Point&gt;</p> <ul style="list-style-type: none"> <li>Two shaft and one hole of Left ASF Frame. Refer to Figure 6-16, "Lubrication point 9".</li> </ul> <p>&lt;Lubrication Type&gt;</p> <ul style="list-style-type: none"> <li>G-26</li> </ul> <p>&lt;Lubrication Amount&gt;</p> <ul style="list-style-type: none"> <li>Whole circle but no pile</li> </ul>	<ul style="list-style-type: none"> <li>Use a brush to apply it.</li> </ul>
10	<p>&lt;Lubrication Point&gt;</p> <ul style="list-style-type: none"> <li>The gear face of Spur Gear 12. Refer to Figure 6-17, "Lubrication point 10".</li> </ul> <p>&lt;Lubrication Type&gt;</p> <ul style="list-style-type: none"> <li>G-26</li> </ul> <p>&lt;Lubrication Amount&gt;</p> <ul style="list-style-type: none"> <li>Whole circle on two end gear face.</li> </ul>	<ul style="list-style-type: none"> <li>Use a brush to apply it.</li> </ul>
11	<p>&lt;Lubrication Point&gt;</p> <ul style="list-style-type: none"> <li>Two shaft and one hole of Right ASF Frame. Refer to Figure 6-18, "Lubrication point 11".</li> </ul> <p>&lt;Lubrication Type&gt;</p> <ul style="list-style-type: none"> <li>G-26</li> </ul> <p>&lt;Lubrication Amount&gt;</p> <ul style="list-style-type: none"> <li>Right round on two shaft and one hole of Right ASF Flame without pile.</li> </ul>	<ul style="list-style-type: none"> <li>Use a brush to apply it.</li> </ul>
12	<p>&lt;Lubrication Point&gt;</p> <ul style="list-style-type: none"> <li>On the shaft of Left ASF Flame unit. Refer to Figure 6-19, "Lubrication point 12".</li> </ul> <p>&lt;Lubrication Type&gt;</p> <ul style="list-style-type: none"> <li>G-26</li> </ul> <p>&lt;Lubrication Amount&gt;</p> <ul style="list-style-type: none"> <li>About 2 or 3 particle</li> </ul>	<ul style="list-style-type: none"> <li>Use a brush to apply it.</li> </ul>

No.	Lubrication Type/Point	Remarks
13	<p><b>&lt;Lubrication Point&gt;</b></p> <ul style="list-style-type: none"> <li>• The “shadow part” of Paper Back Lever Cam. Refer to Figure 6-20, "Lubrication point 13".</li> </ul> <p><b>&lt;Lubrication Type&gt;</b></p> <ul style="list-style-type: none"> <li>• G-26</li> </ul> <p><b>&lt;Lubrication Amount&gt;</b></p> <ul style="list-style-type: none"> <li>• About 2 or 3 particle</li> </ul>	<ul style="list-style-type: none"> <li>• Use a brush to apply it.</li> </ul>
14	<p><b>&lt;Lubrication Point&gt;</b></p> <ul style="list-style-type: none"> <li>• The “slot” of Silence Lever Support. Refer to Figure 6-21, "Lubrication point 14".</li> </ul> <p><b>&lt;Lubrication Type&gt;</b></p> <ul style="list-style-type: none"> <li>• G-26</li> </ul> <p><b>&lt;Lubrication Amount&gt;</b></p> <ul style="list-style-type: none"> <li>• About 2 or 3 particle</li> </ul>	<ul style="list-style-type: none"> <li>• Use a brush to apply it.</li> </ul>
15	<p><b>&lt;Lubrication Point&gt;</b></p> <ul style="list-style-type: none"> <li>• The step face of Silence Cam. Refer to Figure 6-22, "Lubrication point 15".</li> </ul> <p><b>&lt;Lubrication Type&gt;</b></p> <ul style="list-style-type: none"> <li>• G-26</li> </ul> <p><b>&lt;Lubrication Amount&gt;</b></p> <ul style="list-style-type: none"> <li>• About 2 or 3 particle</li> </ul>	<ul style="list-style-type: none"> <li>• Use a brush to apply it.</li> </ul>

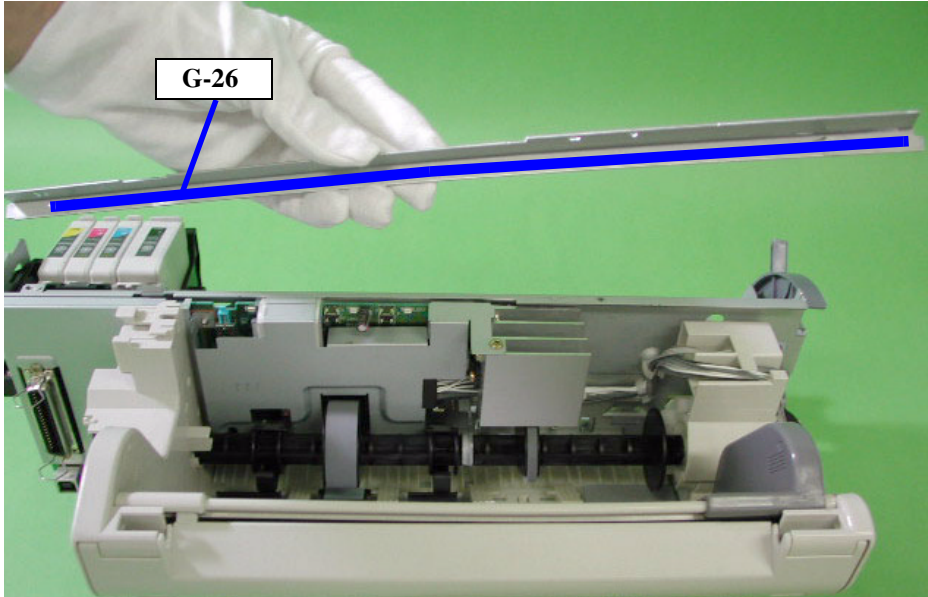

Figure 6-8. Lubrication point 1

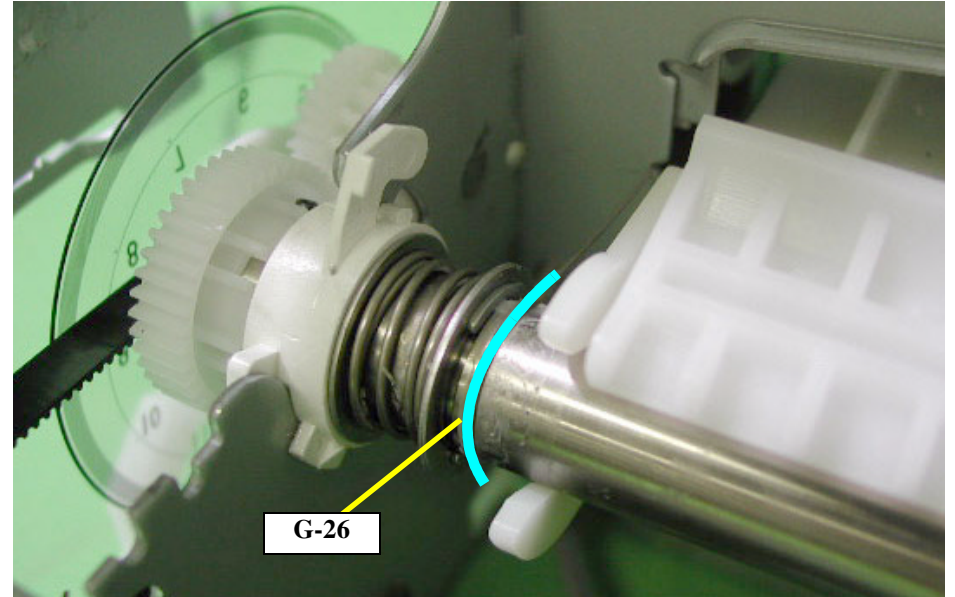

Figure 6-10. Lubrication point 3

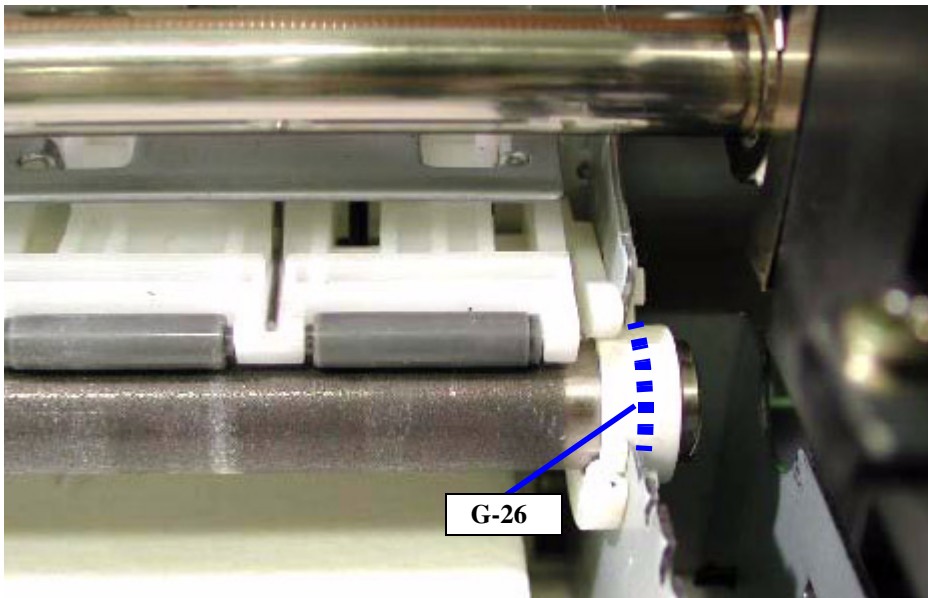

Figure 6-9. Lubrication point 2

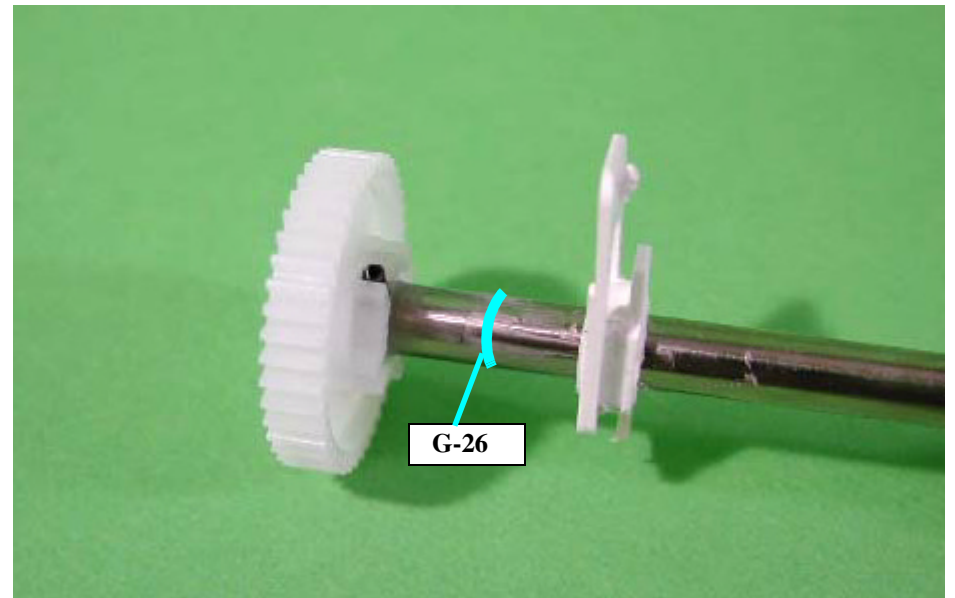

Figure 6-11. Lubrication point 4



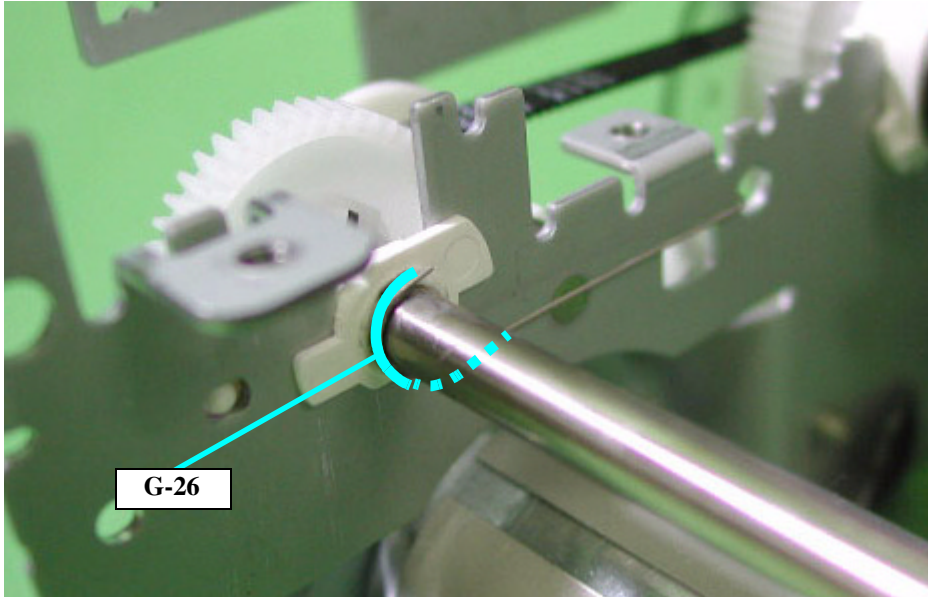

Figure 6-12. Lubrication point 5

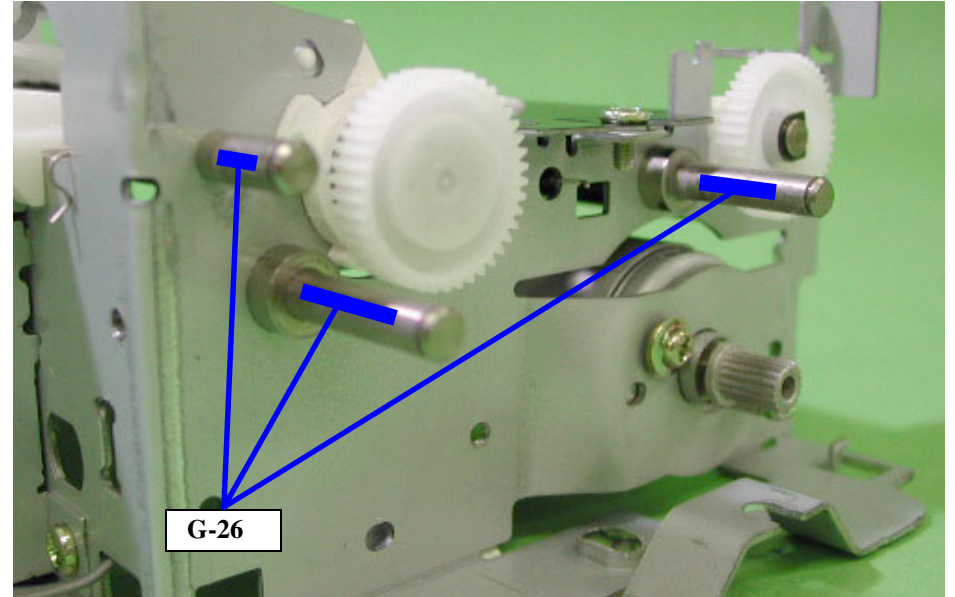

Figure 6-14. Lubrication point 7

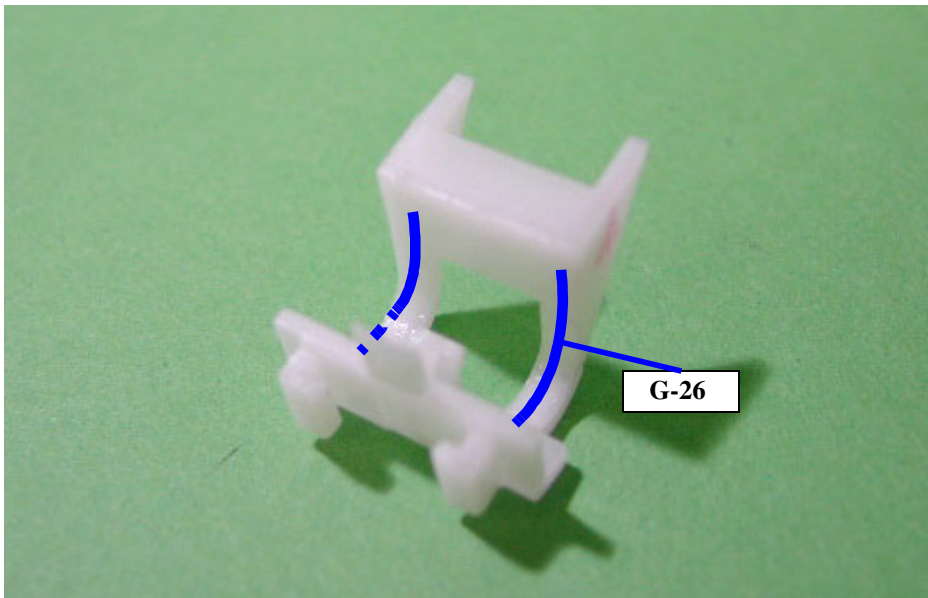

Figure 6-13. Lubrication point 6

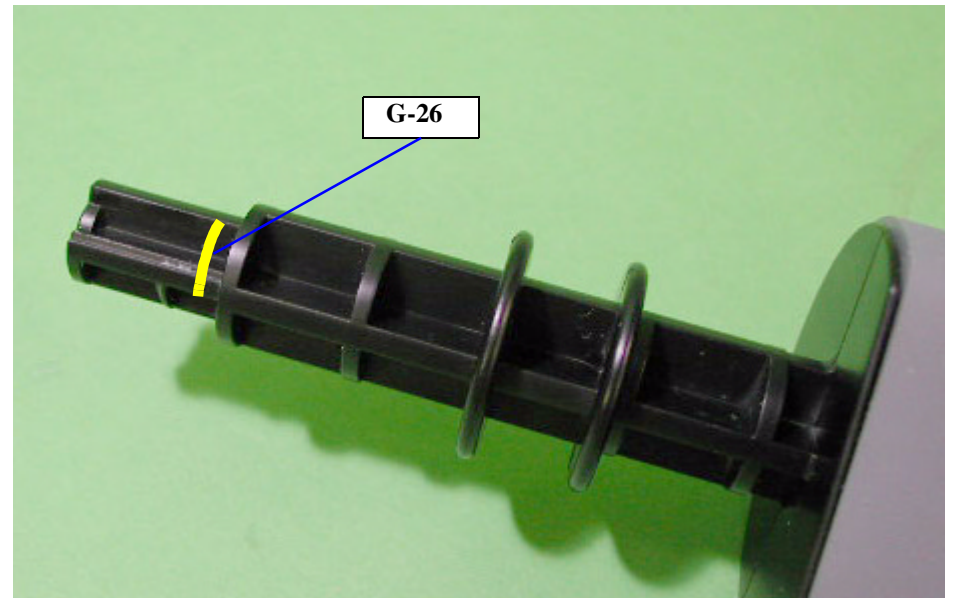

Figure 6-15. Lubrication point 8

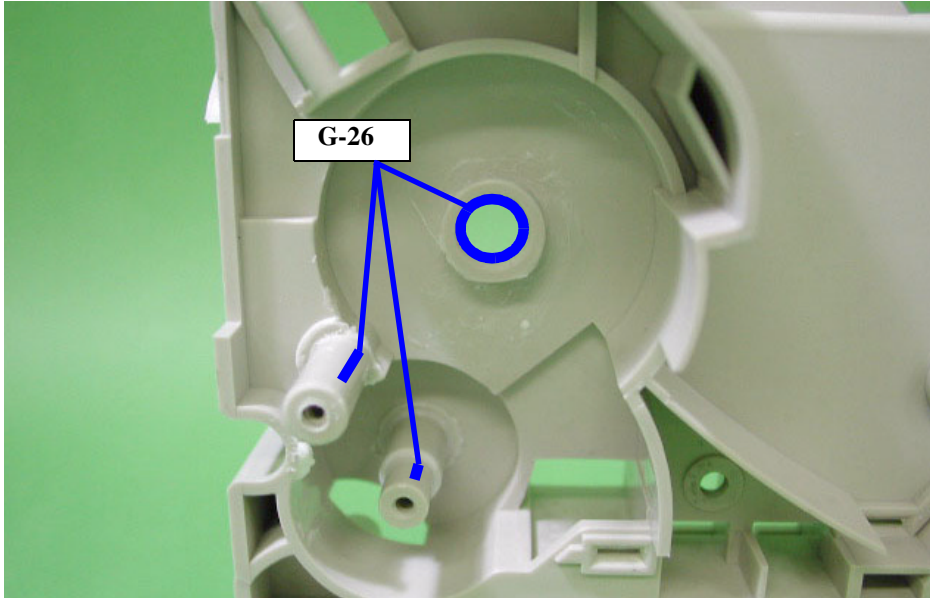

Figure 6-16. Lubrication point 9

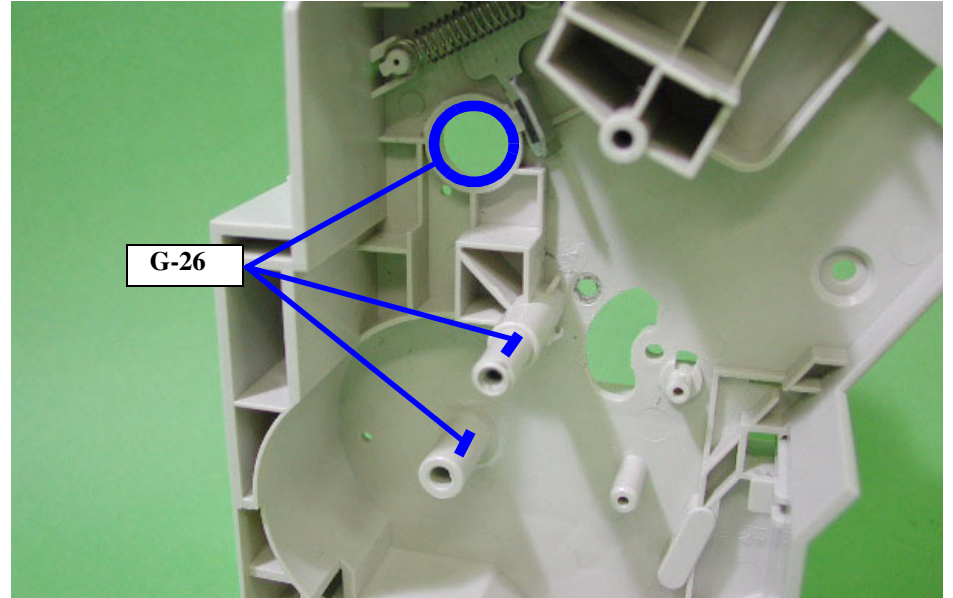

Figure 6-18. Lubrication point 11

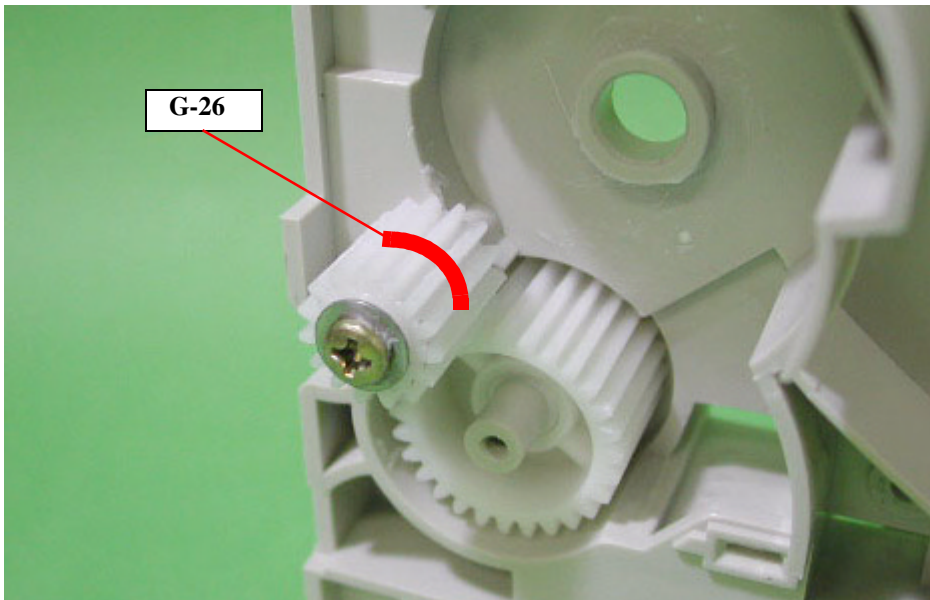

Figure 6-17. Lubrication point 10

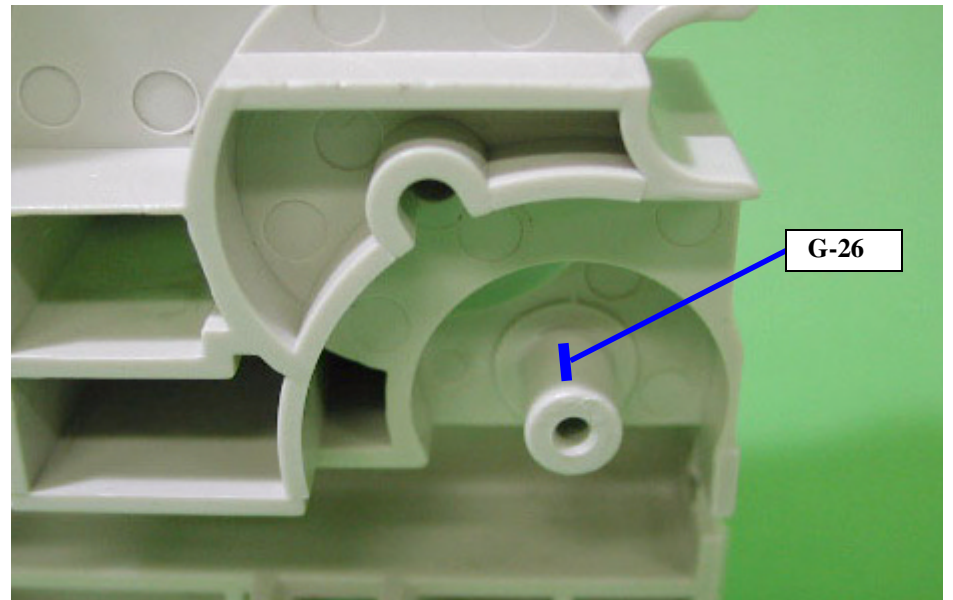

Figure 6-19. Lubrication point 12



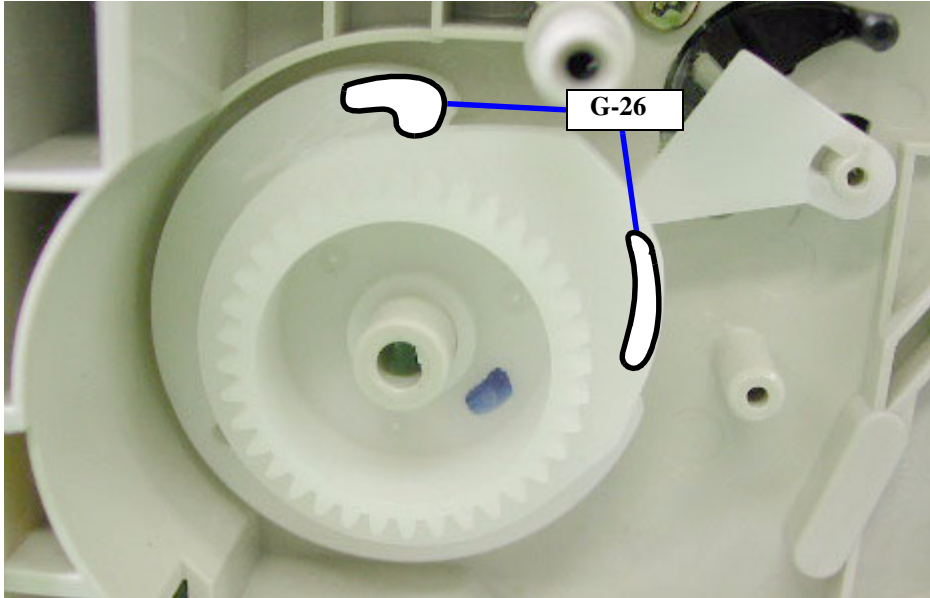

Figure 6-20. Lubrication point 13

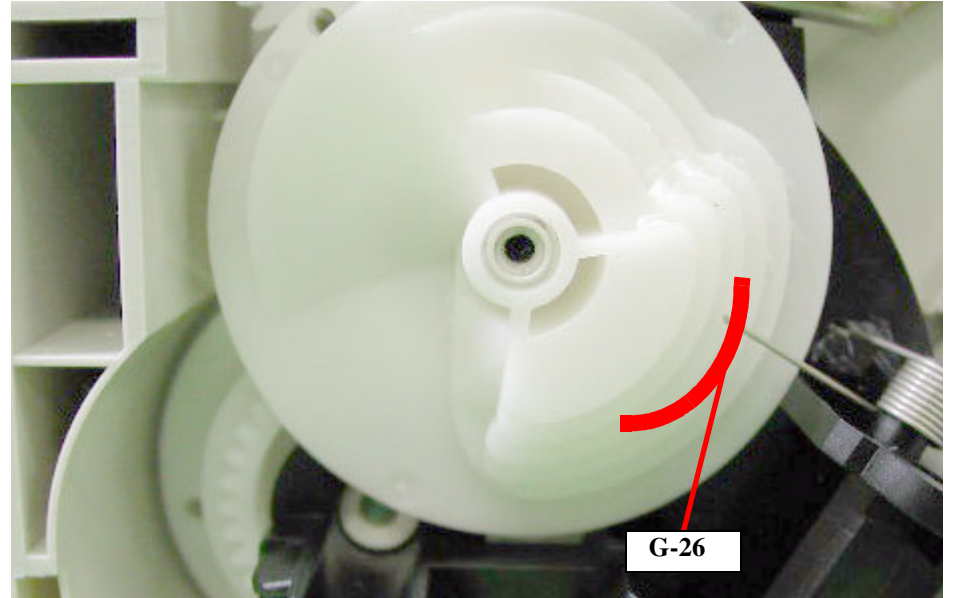

Figure 6-22. Lubrication point 15

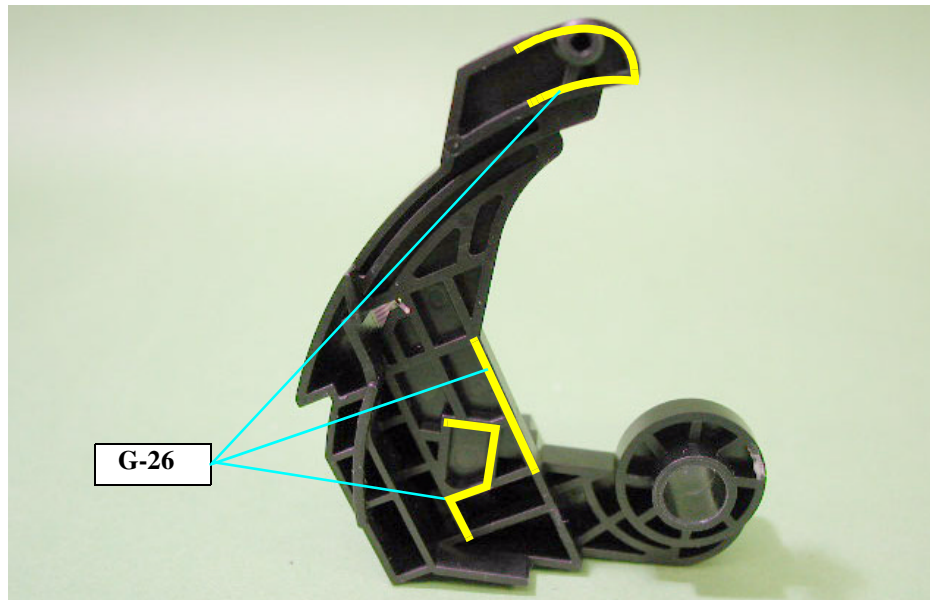

Figure 6-21. Lubrication point 14

**CHAPTER**

**7**

**APPENDIX**

## 7.1 Connector Summary

### 7.1.1 Major Component Unit

The Major component units of this printer are as follows.

- Main Board (C424 MAIN-B)
- Power Supply Board (C424 PSB/PSE)

The figure below shows how these components connect.

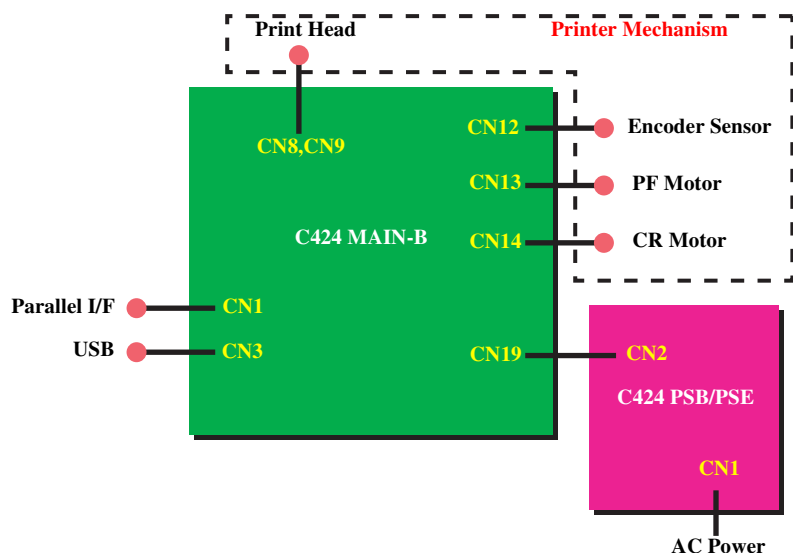

Figure 7-1. Connection of the Major Components

See the following tables for the connector summary for the C424 MAIN Board and each connector's pin alignment.

Table 7-1. Connector Summary for C424 MAIN

Connector	Function	Table to refer to
CN1	For connection with the Parallel Interface	Refer to Table 1-9 Parallel Interface on page.
CN3	For connection with the USB	Refer to Table 1-10 "USB" on page.
CN8,CN9	For connection with the Print Head	Table 7-2, Table 7-3
CN12	For connection with the PF Encoder	Table 7-4
CN13	For connection with the PF Motor	Table 7-5
CN14	For connection with the CR Motor	Table 7-6
CN19	For connection with the Power Supply Board	Table 7-7

Table 7-2. CN8 - Print Head

Pin	Signal Name	I/O	Function
1	GND2	-	Ground 2
2	COM	Out	Head drive pulse (trapezoid waveform)
3	GND2	-	Ground 2
4	COM	Out	Head drive pulse (trapezoid waveform)
5	GND2	-	Serial Clock
6	COM	Out	Ground 2
7	GND2	-	Ground 2
8	COM	Out	Head drive pulse (trapezoid waveform)
9	GND2	-	Ground 2
10	GND	-	Ground
11	TH	In	Thermistor detect signal
12	VCC3.3	Out	Logic power supply (+3.3V)
13	GND	-	Ground
14	NC	-	Not connected
15	GND	-	Ground
16	ENCA	In	Encoder feed back signal ch.A
17	EVDD	Out	Power for CR Encoder
18	ENCB	In	Encoder feed back signal ch.B
19	GND	-	Ground
20	CRST	Out	Reset signal for address counter of CSIC
21	GND	-	Ground
22	CSCK	IN/Out	Clock signal for CSIC read/write
23	CVDD	Out	Power for CSIC memory

Table 7-2. CN8 - Print Head

Pin	Signal Name	I/O	Function
24	CSD	Out	CSIC serial data
25	GND	-	Ground
26	COO	In	Cartridge out signal

**Table 7-3. CN9 - Print Head**

Pin	Signal Name	I/O	Function
1	GND	-	Ground
2	SI2	Out	Print data output for color nozzles
3	GND	-	Ground
4	SI1	Out	Print data output for black nozzles
5	GND	-	Ground
6	SCK	Out	Serial clock
7	GND	-	Ground
8	CH	Out	Charge signal for the Trapizoidal wave-form
9	GND	-	Ground
10	AND2	In	Abnormal temperature dection circuit for the color nozzles
11	GND	-	Ground
12	AND1	In	Abnormal temperature dection circuit for the black nozzles
13	GND	-	Ground
14	LAT	Out	Head data latch pulse output by 64 bit
15	VCC3.3	Out	Power for CSIC chip or nozzle selector IC
16	NCHG	Out	Source signal for driving Trapizoidal wave-form
17	GND	-	Ground
18	COM	Out	Head drive pulse (trapezoid waveform)
19	GND	-	Ground
20	COM	Out	Head drive pulse (trapezoid waveform)
21	GND	-	Ground
22	COM	Out	Head drive pulse (trapezoid waveform)
23	GND	-	Ground

**Table 7-3. CN9 - Print Head**

Pin	Signal Name	I/O	Function
24	COM	Out	Head drive pulse (trapezoid waveform)
25	GND	-	Ground
26	VHV	Out	+42V for the common voltage

**Table 7-4. CN12 - PF Encoder**

Pin	Signal Name	I/O	Function
1	ENA	In	Feed-back signal from PF encoder ch.A
2	GND	-	Ground
3	ENB	In	Feed-back signal from PF encoder ch.B
4	VCC	Out	Power for the PF encoder

**Table 7-5. CN13 - PF Motor**

Pin	Signal Name	I/O	Function
1	PF-A	Out	Phase drive signal (-A)
2	PF-B	Out	Phase drive signal (-B)

**Table 7-6. CN14 - CR Motor**

Pin	Signal Name	I/O	Function
1	CR-A	Out	Phase drive signal (-A)
2	CR-B	Out	Phase drive signal (-B)

**Table 7-7. CN19 - Power Supply Board**

Pin	Signal Name	I/O	Function
1	+42V	Out	Power supply
2	+42V	Out	Power supply
3	GND	-	Ground

Table 7-7. CN19 - Power Supply Board

Pin	Signal Name	I/O	Function
4	GND	-	Ground
5	PSC	Out	Power on/off switch (CPU monitors)
6	+5V	Out	Logic power supply
7	+5V	Out	Logic power supply
8	GND	-	Ground



### 7.1.2 EEPROM Address Map

Table 7-8. EEPROM Address Map

Address	Explanation	Setting	QPIT setting	Factory settings
00H	Password		0FH	-
01H			5AH	-
02H	Ink counter A		Stylus C80: : 00H	Stylus C80: : 00H
03H			Stylus C80: : 00H	Stylus C80: : 00H
04H	CSIC1 ink name1			
05H	CSIC2 ink name1			
06H	CSIC3 ink name1			
07H	CSIC4 ink name1			
08H	Ink counter R0		Stylus C80: : 00H	Stylus C80: : 00H*3
09H			Stylus C80: : 00H	Stylus C80: : 00H*3
0AH	Ink counter R80		Stylus C80: : 00H	Stylus C80: : 00H*3
0BH			Stylus C80: : 00H	Stylus C80: : 00H*3
0CH   0FH	Reserved		00H   00H	-   -
10H   13H	Ink counter Cb		Stylus C80: : 00H   00H	Stylus C80: : 00H   00H

Table 7-8. EEPROM Address Map (continued)

Address	Explanation	Setting	QPIT setting	Factory settings
14H   17H	Ink counter Cy		Stylus C80: : 00H   00H	Stylus C80: : 00H   00H
18H   1BH	Ink counter Cm		Stylus C80: : 00H   00H	Stylus C80: : 00H   00H
1CH   1FH	Ink counter Cc		Stylus C80: : 00H   00H	Stylus C80: : 00H   00H
20H   23H	Page counter		Stylus C80: : 00H   00H	Stylus C80: : 00H   00H
24H   27H	Printer pass counter		Stylus C80: : 00H   00H	Stylus C80: : 00H   00H
28H   2DH	CPSI password		Stylus C80: : 00H   00H	Stylus C80: : 00H   00H
2EH	Error Code		00H	00H
2FH	Error Counter at initial fill I/S		00H	Stylus C80: : (*1)

Table 7-8. EEPROM Address Map (continued)

Address	Explanation	Setting	QPIT setting	Factory settings
30H	Ink flag1	Bit7: Disable CSIC Bit6: Black one-time Bit5: Color one-time Bit4: Initial fill required Bit3: Reserved Bit2: Ink cleaning seq. Bit1: Black CL required Bit0: Color CL required	00H	Stylus C80: 10H
31H	Ink flag2	Bit7: Reserved Bit6: Black 1 <sup>st</sup> ink cartridge Bit5: Color 1 <sup>st</sup> ink cartridge Bit4: Bk CSIC chg. seq. required Bit3: YMC CSIC chg. seq. required Bit2: Color ink cartridge changed Bit1: Black ink cartridge changed Bit0: Black cartridge changed alone	00H	Stylus C80: 00H
32H	Ink flag3	Bit7: Reserved Bit6: Reserved Bit5: Reserved Bit4: Reserved Bit3: Reserved Bit2: Reserved Bit1: Reserved Bit0: Reserved	Stylus C80: 00H	Stylus C80: 00H
33H	CL2 KK-Counter		Stylus C80: 00H	Stylus C80: 00H

Table 7-8. EEPROM Address Map (continued)

Address	Explanation	Setting	QPIT setting	Factory settings
34H	Printing time		Stylus C80: 00H	Stylus C80: 00H
35H			Stylus C80: 00H	Stylus C80: 00H
36H	CL time		Stylus C80: 00H	Stylus C80: 00H*2
37H			Stylus C80: 00H	Stylus C80: 00H*2
38H	Power off time		Stylus C80: 00H	Stylus C80: 00H*2
39H			Stylus C80: 00H	Stylus C80: 00H*2
3AH	Current time		Stylus C80: 00H	Stylus C80: 00H
3BH			Stylus C80: 00H	Stylus C80: 00H
3CH	CR duty		Stylus C80: 00H	
3DH   3FH	Reserved		Stylus C80: 00H   00H	Stylus C80: -   -
40H	Password		0FH	-
41H			5AH	-

Table 7-8. EEPROM Address Map (continued)

Address	Explanation	Setting	QPIT setting	Factory settings
42H	Ink seq. A counter			
43H	Ink seq. B counter			
44H	Ink seq. C counter			
45H	Ink seq. D counter			
46H	Ink seq. E counter			
47H	Ink seq. F counter			
48H	Ink seq. G counter			
49H	Ink seq. H counter			
4AH   4FH	Reserved		00H   00H	-   -
50H	Print direction control	0: Bi-D      1: Uni-D 2: Auto	02H	02H

Table 7-8. EEPROM Address Map (continued)

Address	Explanation	Setting	QPIT setting	Factory settings
51H	CG table	Stylus C70: 0 : Italic U.S.A. 1 : Italic France 2 : Italic Germany 3 : Italic U.K 4 : Italic Denmark 5 : Italic Sweden 6 : Italic Italy 7 : Italic Spain 8 : PC 437 9 : PC 437 Greek 10 : PC 850 11 : PC 860 12 : PC 863 13 : PC 865 14 : PC 861 15 : BRASCI 16 : Abicomp 17 : Roman 8 18 : ISO Latin 1 19 : PC 853 20 : PC 855 21 : PC 852 22 : PC 857 23 : PC 866 24 : PC 869 25 : MAZOWIA 26 : Code MJK 27 : ISO 8859-7 28 : ISO Latin 1T 29 : Bulgaria 30 : PC 774 31 : Estonia 32 : ISO 8859-2 33 : PC 866 LAT 34 : PC 866UKR 35 : PC AR864 36 : PC APTEC 37 : PC 708 38 : PC 720 39 : Hebrew7 40 : Hebrew8 41 : PC 862 42 : PC 858 43 : ISO 8859-15	00H	08H

Table 7-8. EEPROM Address Map (continued)

Address	Explanation	Setting	QPIT setting	Factory settings
51H	CG table	Stylus C80: 8 : PC 437 10 : PC 850	00H	08H
52H	Font	Stylus C70: 0 : Roman 2 : Courier 7 : Draft Stylus C80: 2: Courier	00H	02H
53H	Pitch	Stylus C70: 0 : 10cpi 1 : 12cpi 2 : 15cpi 5 : Proportional Stylus C80: 0: 10cpi	00H	00H
54H	Check mode control	Bit7: Self test mode Bit6: Hex dump mode Bit5: Reserved Bit4: Reserved Bit3: Reserved Bit2: Reserved Bit1: Reserved Bit0: Reserved	00H	00H
55H	Auto LF	Bit7: Reserved Bit6: Reserved Bit5: Reserved Bit4: Reserved Bit3: Reserved Bit2: Reserved Bit1: Reserved Bit0: Auto line feed (0=Off, 1=On)	00H	00H
56H   59H	Reserved		00H   00H	-   -

Table 7-8. EEPROM Address Map (continued)

Address	Explanation	Setting	QPIT setting	Factory settings
5AH	Page length	1244 to 44 x 360*	1EH	1EH
5BH			F0H	F0H
5CH	Top margin	42 to 44 x 360*	00H	00H
5DH			78H	78H
5EH	Bottom margin	1244 to 44 x 360*	1Eh	1Eh
5FH			F0H	F0H
60H	Interface selection	0: Auto 1: Parallel 3: USB	00H	00H
61H	Interface time-out	0 to 255 (by second, value of 0 means 10 seconds)	0AH	0AH
62H	Compatibility speed			
63H	ECP speed	0: Fast 1: Slow	00H	00H
64H	IEEE1284.4 for parallel	0: Auto 1: On 2: Off	00H	01H
65H	IEEE1284.4 for USB	0: Auto 1: On 2: Off	00H	01H
66H	I/F control flags	Bit7: Reserved Bit6: Reserved Bit5: Reserved Bit4: Reserved Bit3: Reserved Bit2: Reserved Bit1: ECP mode (0 = Off, 1 = On) Bit0: IEEE1284 mode (0 = On, 1 = Off)	00H	00H
67H   6FH	Reserved		00H   00H	-   -
70H	Bi-D adjustment for ECO (Black)	-60 <= n <= +60 **	00H	(*1)

Table 7-8. EEPROM Address Map (continued)

Address	Explanation	Setting	QPIT setting	Factory settings
71H	Bi-D adjustment for ECO (Color)	-60 <= n <= +60 **	00H	(*1)
72H	Bi-D adjustment for VSD1 (Black)	-60 <= n <= +60 **	00H	(*1)
73H	Bi-D adjustment for VSD1 (Color)	-60 <= n <= +60 **	00H	(*1)
74H	Bi-D adjustment for VSD2 (Black)	-60 <= n <= +60 **	00H	(*1)
75H	Bi-D adjustment for VSD2 (Color)	-60 <= n <= +60 **	00H	(*1)
76H	Bi-D adjustment for VSD3 (Black)	-60 <= n <= +60 **	00H	(*1)
77H	Bi-D adjustment for VSD3 (Color)	-60 <= n <= +60 **	00H	(*1)
78H   7BH	Measurement data xxx		00H   00H	(*1)   (*1)
7CH	1 <sup>st</sup> dot position adjustment		00H	(*1)
7DH	PF position adjustment		00H	(*1)
7EH	Reserved		00H	-
7FH			00H	-
80H	Password		0FH	-
81H			5AH	-
82H   8FH	Reserved		00H   00H	-   -
90H   9FH			Reserved	
A0H	Head actuator rank ID for Vh1L			
A1H	Head actuator rank ID for Vh2M		00H	(*1)

Table 7-8. EEPROM Address Map (continued)

Address	Explanation	Setting	QPIT setting	Factory settings
A2H	Head actuator rank ID for Vh2S		00H	(*1)
A3H	Head actuator rank ID for Vh3M		00H	(*1)
A4H	Head actuator rank ID for Vh3S		00H	(*1)
A5H	Reserved for Head actuator rank ID		00H   00H	Stylus C70: (*1)   (*1)
A6H				
A7H	Reserved for Microweave ID			
A8H	Head actuator rank ID for IwB			
A9H	Head actuator rank ID for IwC			
AAH	Head actuator rank ID for IwM			
ABH	Head actuator rank ID for IwY			
ACH	Reserved for Head actuator rank ID			
ADH				
AEH	Head actuator rank ID for Tc		Stylus C80: 00H	Stylus C80: (*1)
AFH	TG Maker		Stylus C80: 00H	Stylus C80: (*1)
B0H	CSIC printer name		00H	Stylus C70: 94H Stylus C80: 95H
B1H   BFH	Reserved		00H   00H	-   -
C0H			Password	
C1H	5AH	-		

Table 7-8. EEPROM Address Map (continued)

Address	Explanation	Setting	QPIT setting	Factory settings
C2H   D3H	USB ID		00H   00H	(*1)   (*1)
D4H   D7H	Reserved		00H   00H	-   -
D8H   DBH	Custom EEPROM sub number		00H   00H	00H   00H
DCH	Panel mask function	Bit7: Entry Self-Test Bit6: Entry Hex-Dump Bit5: Extended settings Bit4: Reserved Bit3: Reserved Bit2: Cleaning Bit1: Replace I/C Bit0: Load/Eject	00H	00H
DDH   DFH	Reserved		00H   00H	-   -
E0H	EEPROM mapping revision		xxH	
E1H	Market ID	0: STD    2: Custom	00H	00H
E2H   FFH	Model name		00H   00H	-   -

**NOTE:** \*1 Adjusted at factory.

\*2 Initialized after performed panel initialization of EEPROM.

\*3 Initialized after performed panel initialization of the ink overflow in EEPROM.

**NOTE:** \* By 0.0706 mm (1/360 inch)

\*\* By 0.0176 mm (1/1440 inch)



### 7.1.3 CSIC Address Map

Table 7-9. CSIC Address Map

Address	Explanation	Setting	Factory settings
00H	CSIC_B Ink Counter		(*1)
01H	CSIC_B Cleaning Counter		(*1)
02H	CSIC_B Install Counter		(*1)
03H	CSIC_B Install Printer		(*1)
04H   09H	Reserved		(*1)   (*1)
0AH	CSIC_B Product Year		(*1)
0BH	CSIC_B Product Month		(*1)
0CH	CSIC_B Product Day		(*1)
0DH	CSIC_B Product Hour		(*1)
0EH	CSIC_B Product Minute		(*1)
0FH	CSIC_B Product Serial Number		(*1)
10H	CSIC_B Product Line1 L		(*1)
11H	CSIC_B Product Line1 H		(*1)
12H	CSIC_B Product Line2		(*1)
13H	CSIC_B Recycle Counter		(*1)
14H	CSIC_B Cartridge Name1 L		(*1)
15H	CSIC_B Cartridge Name1 H		(*1)
16H	CSIC_B Cartridge Name2 L		(*1)
17H	CSIC_B Cartridge Name2 H		(*1)
18H	CSIC_B Ink Name1		(*1)
19H	CSIC_B Ink Name2		(*1)
1AH	CSIC_B Effect Period		(*1)

Table 7-9. CSIC Address Map (continued)

Address	Explanation	Setting	Factory settings
1BH	CSIC_B Open Effect Period		(*1)
1CH	CSIC_B Check ID		(*1)
1DH	Reserved		(*1)
1EH   27H	CSIC_B Product Company		(*1)   (*1)
28H   3FH	Reserved		(*1)   (*1)
40H	CSIC_C Ink Counter		(*1)
41H	CSIC_C Cleaning Counter		(*1)
42H	CSIC_C Install Counter		(*1)
43H	CSIC_C Install Printer		(*1)
44H   49H	Reserved		(*1)   (*1)
4AH	CSIC_C Product Year		(*1)
4BH	CSIC_C Product Month		(*1)
4CH	CSIC_C Product Day		(*1)
4DH	CSIC_C Product Hour		(*1)
4EH	CSIC_C Product Minute		(*1)
4FH	CSIC_C Product Serial Number		(*1)
50H	CSIC_C Product Line1 L		(*1)
51H	CSIC_C Product Line1 H		(*1)
52H	CSIC_C Product Line2		(*1)
53H	CSIC_C Recycle Counter		(*1)

Table 7-9. CSIC Address Map (continued)

Address	Explanation	Setting	Factory settings
54H	CSIC_C Cartridge Name1 L		(*1)
55H	CSIC_C Cartridge Name1 H		(*1)
56H	CSIC_C Cartridge Name2 L		(*1)
57H	CSIC_C Cartridge Name2 H		(*1)
58H	CSIC_C Ink Name1		(*1)
59H	CSIC_C Ink Name2		(*1)
5AH	CSIC_C Effect Period		(*1)
5BH	CSIC_C Open Effect Period		(*1)
5CH	CSIC_C Check ID		(*1)
5DH	Reserved		(*1)
5EH   67H	CSIC_C Product Company		(*1)   (*1)
68H   7FH	Reserved		(*1)   (*1)
80H	CSIC_M Ink Counter		(*1)
81H	CSIC_M Cleaning Counter		(*1)
82H	CSIC_M Install Counter		(*1)
83H	CSIC_M Install Printer		(*1)
84H   89H	Reserved		(*1)   (*1)
8AH	CSIC_M Product Year		(*1)
8BH	CSIC_M Product Month		(*1)
8CH	CSIC_M Product Day		(*1)

Table 7-9. CSIC Address Map (continued)

Address	Explanation	Setting	Factory settings
8DH	CSIC_M Product Hour		(*1)
8EH	CSIC_M Product Minute		(*1)
8FH	CSIC_M Product Serial Number		(*1)
90H	CSIC_M Product Line1 L		(*1)
91H	CSIC_M Product Line1 H		(*1)
92H	CSIC_M Product Line2		(*1)
93H	CSIC_M Recycle Counter		(*1)
94H	CSIC_M Cartridge Name1 L		(*1)
95H	CSIC_M Cartridge Name1 H		(*1)
96H	CSIC_M Cartridge Name2 L		(*1)
97H	CSIC_M Cartridge Name2 H		(*1)
98H	CSIC_M Ink Name1		(*1)
99H	CSIC_M Ink Name2		(*1)
9AH	CSIC_M Effect Period		(*1)
9BH	CSIC_M Open Effect Period		(*1)
9CH	CSIC_M Check ID		(*1)
9DH	Reserved		(*1)
9EH   A7H	CSIC_M Product Company		(*1)   (*1)
A8H   BFH	Reserved		(*1)   (*1)
C0H	CSIC_Y Ink Counter		(*1)
C1H	CSIC_Y Cleaning Counter		(*1)
C2H	CSIC_Y Install Counter		(*1)

Table 7-9. CSIC Address Map (continued)

Address	Explanation	Setting	Factory settings
C3H	CSIC_Y Install Printer		(*1)
C4H   C9H	Reserved		(*1)   (*1)
CAH	CSIC_Y Product Year		(*1)
CBH	CSIC_Y Product Month		(*1)
CCH	CSIC_Y Product Day		(*1)
CDH	CSIC_Y Product Hour		(*1)
CEH	CSIC_Y Product Minute		(*1)
CFH	CSIC_Y Product Serial Number		(*1)
D0H	CSIC_Y Product Line1 L		(*1)
D1H	CSIC_Y Product Line1 H		(*1)
D2H	CSIC_Y Product Line2		(*1)
D3H	CSIC_Y Recycle Counter		(*1)
D4H	CSIC_Y Cartridge Name1 L		(*1)
D5H	CSIC_Y Cartridge Name1 H		(*1)
D6H	CSIC_Y Cartridge Name2 L		(*1)
D7H	CSIC_Y Cartridge Name2 H		(*1)
D8H	CSIC_Y Ink Name1		(*1)
D9H	CSIC_Y Ink Name2		(*1)
DAH	CSIC_Y Effect Period		(*1)
DBH	CSIC_Y Open Effect Period		(*1)
DCH	CSIC_Y Check ID		(*1)

Table 7-9. CSIC Address Map (continued)

Address	Explanation	Setting	Factory settings
DDH	Reserved		(*1)
DEH   E7H	CSIC_Y Product Company		(*1)   (*1)
E8H   FFH	Reserved		(*1)   (*1)

NOTE: (\*1) Adjusted at factory.

## 7.2 Component Layout

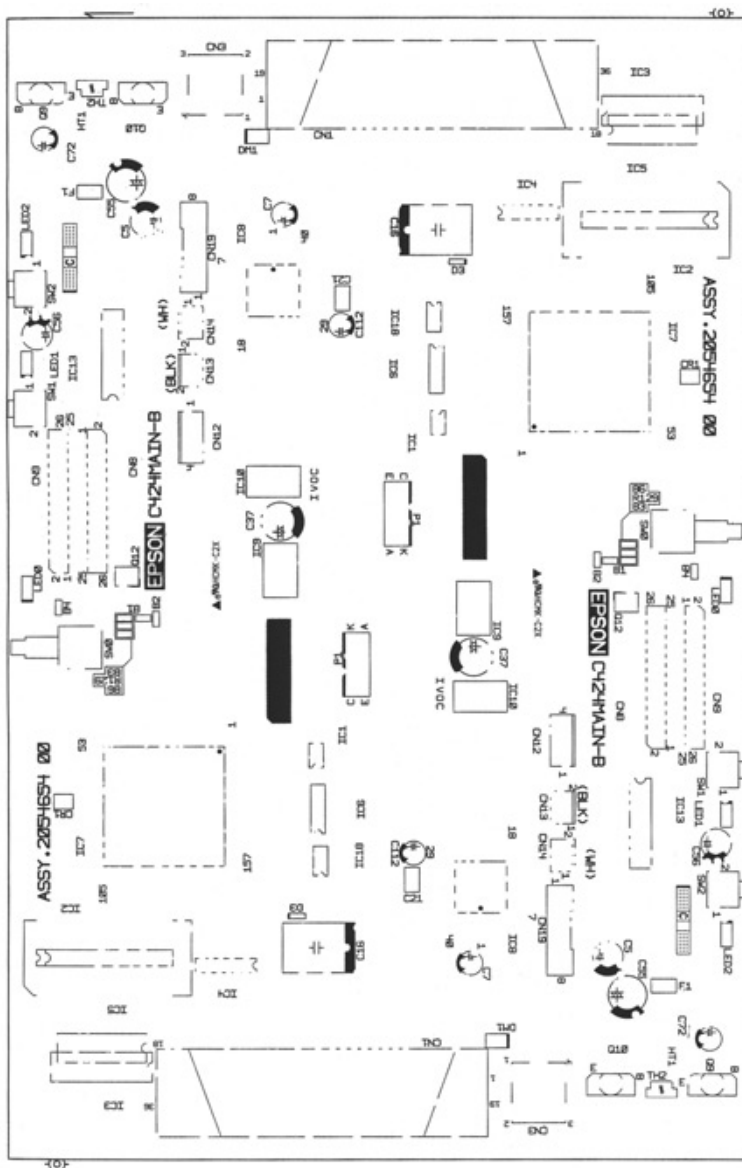

Figure 7-2. C424 MAIN Component Layout (Parts Side)

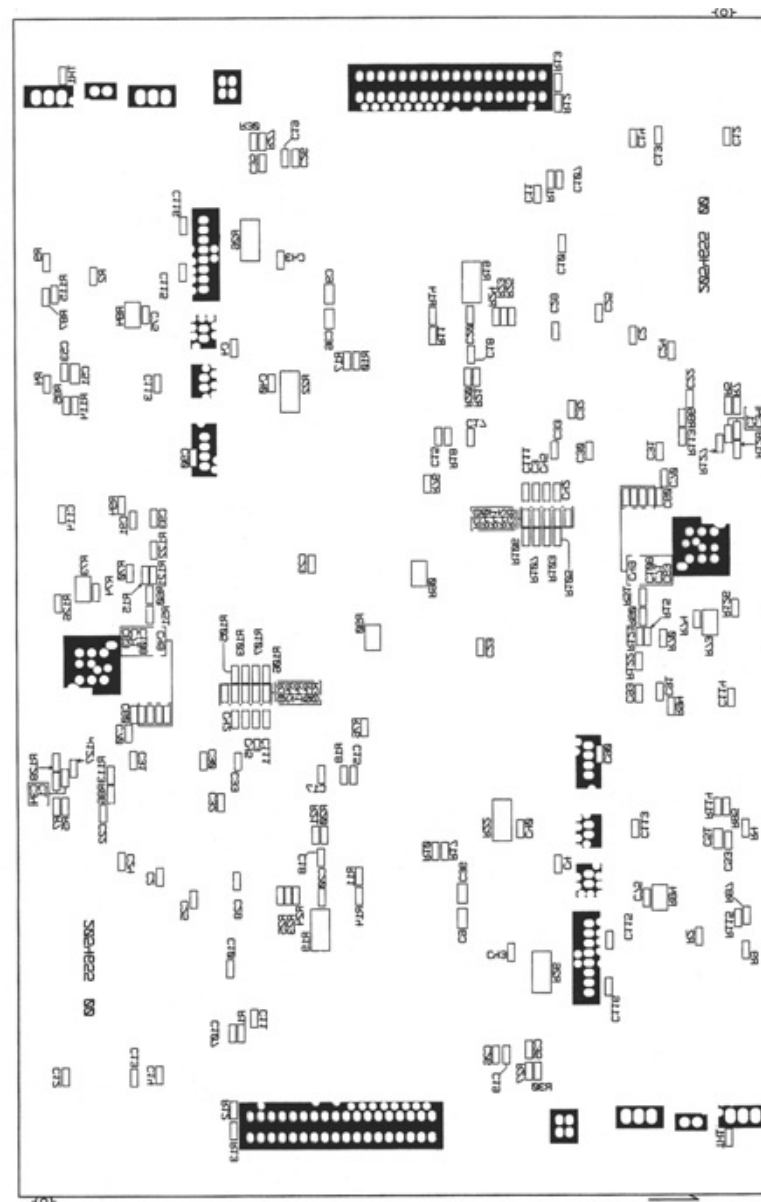

Figure 7-3. C424 MAIN-B Component Layout (Foil Side)

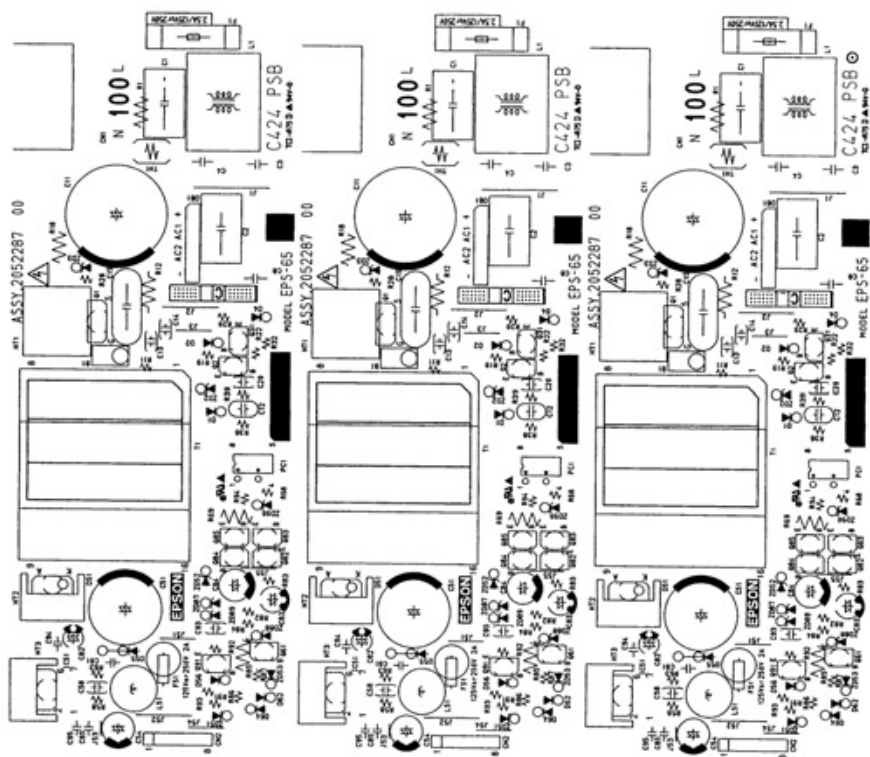

Figure 7-4. C424 PSB Component Layout

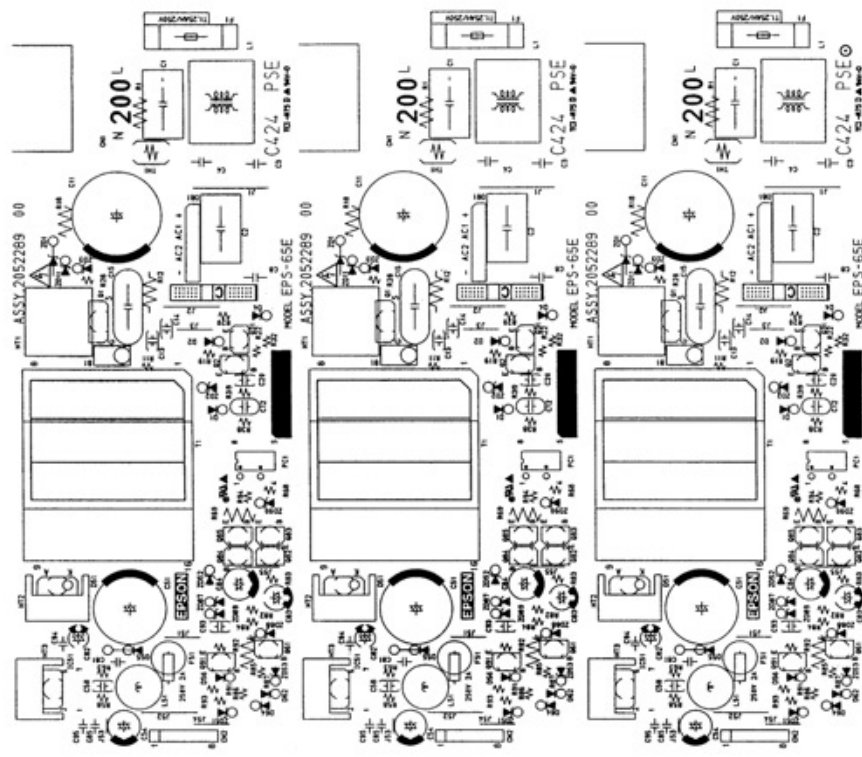
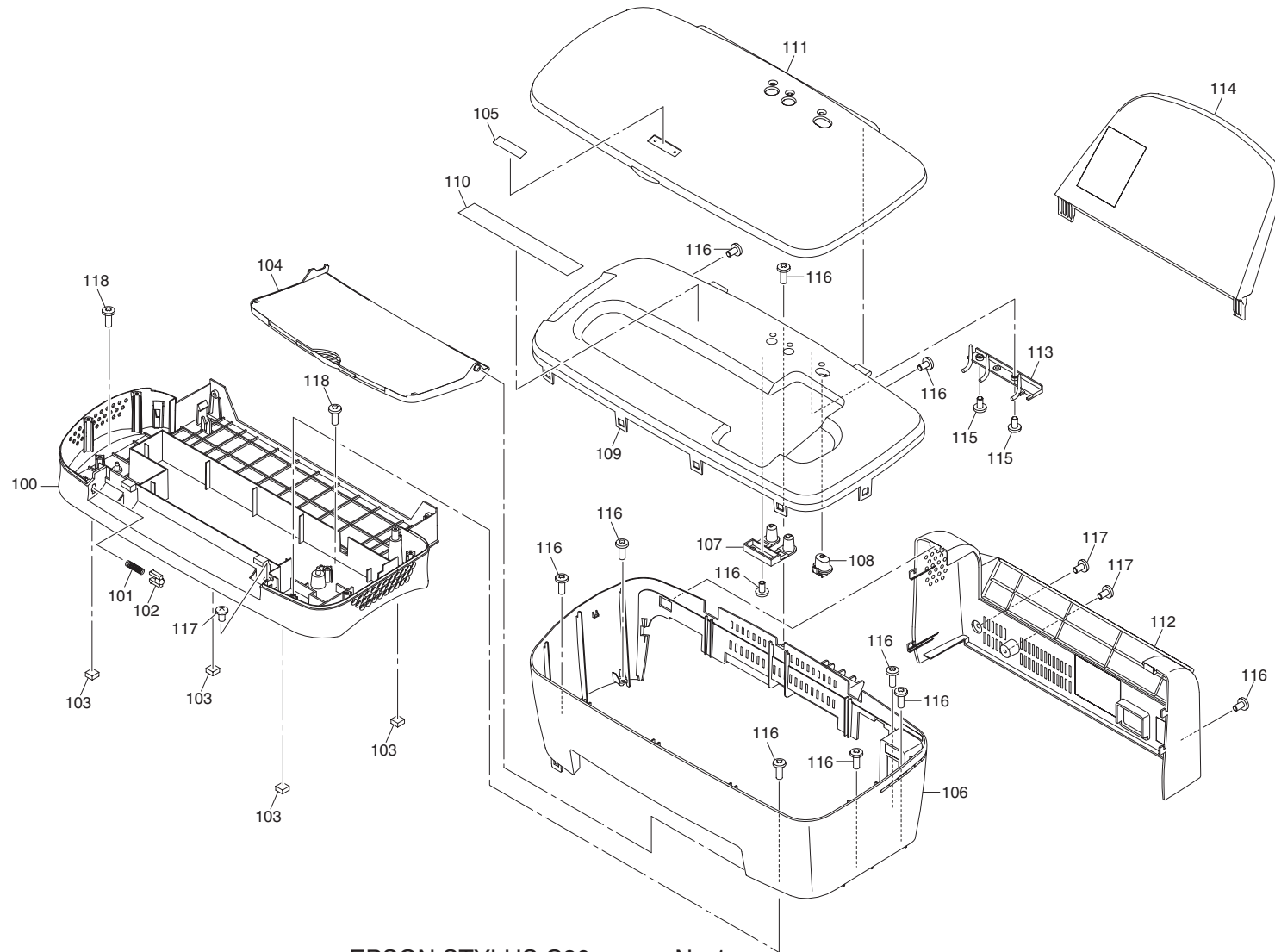

Figure 7-5. C424 PSE Component Layout

### 7.3 Exploded Diagram

Following pages show exploded diagram.



EPSON STYLUS C80 No.1 Rev.01 10336

Figure 7-6. Stylus Color C70/C80 Exploded Diagram 1



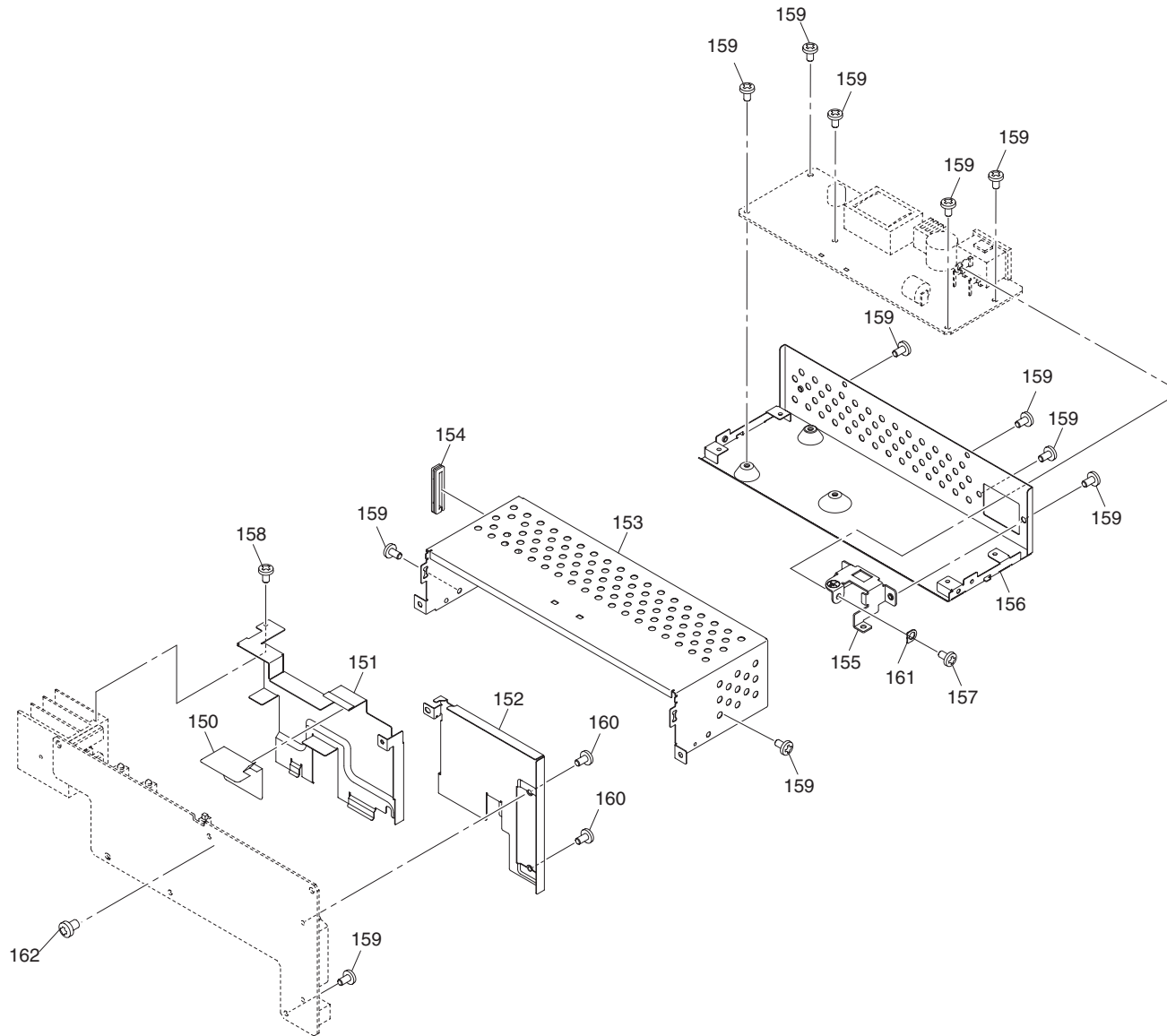

EPSON STYLUS C80 No.2 Rev.01 10336

Figure 7-7. Stylus Color C70/C80 Exploded Diagram 2

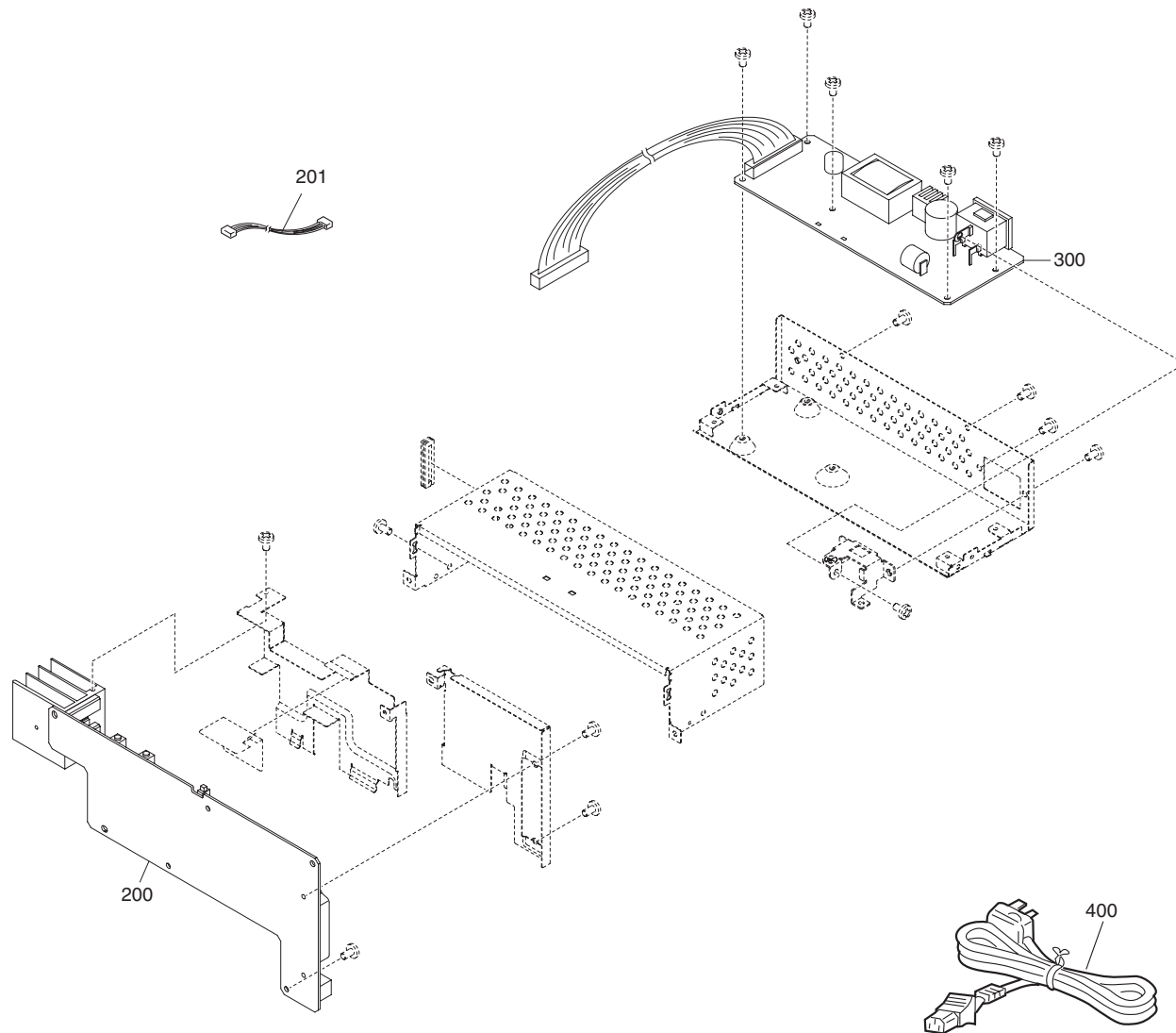

EPSON STYLUS C80      No.3      Rev.01      10336

Figure 7-8. Stylus Color C70/C80 Exploded Diagram 3

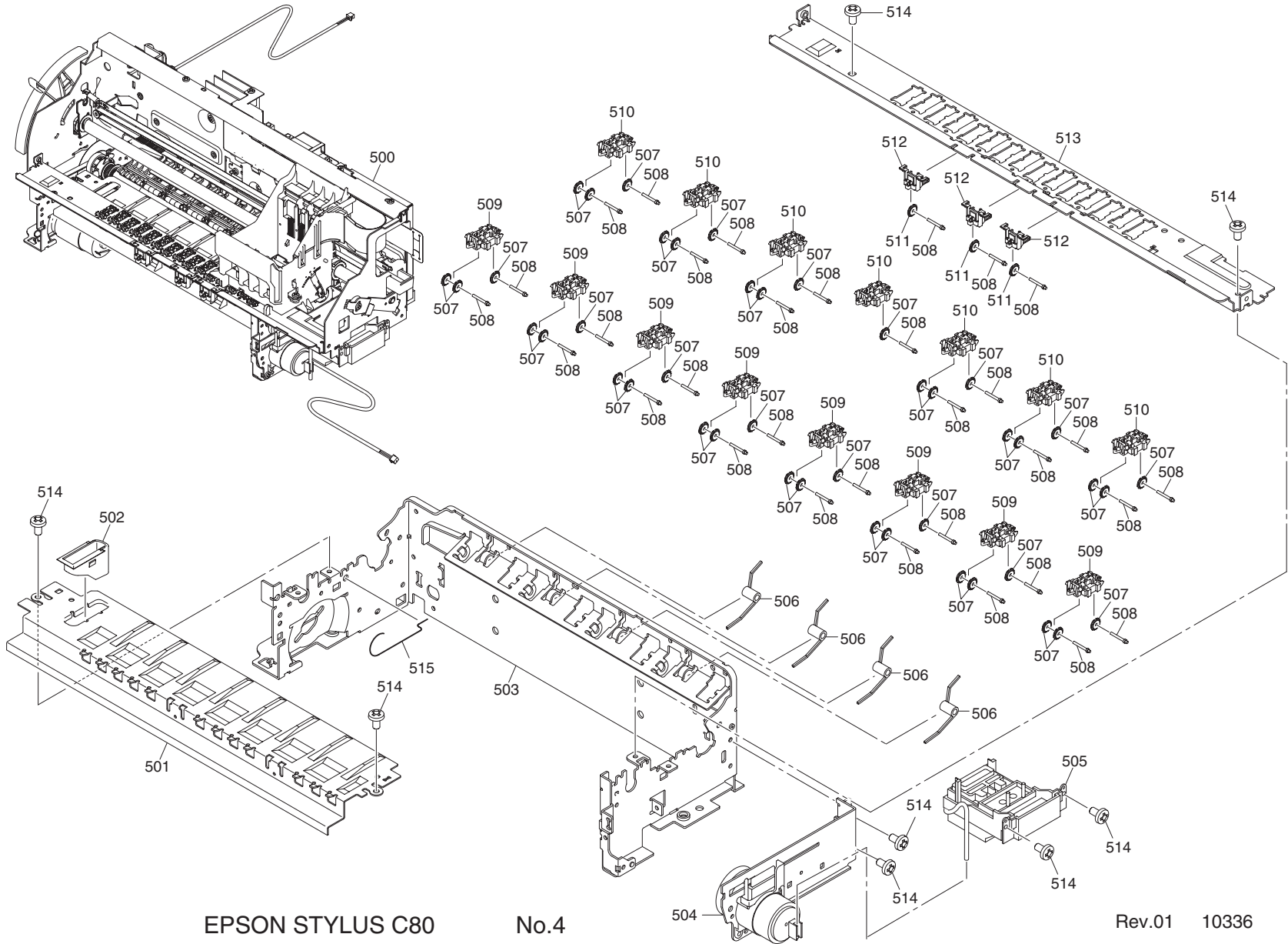

EPSON STYLUS C80

No.4

Rev.01 10336

Figure 7-9. Stylus Color C70/C80 Exploded Diagram 4

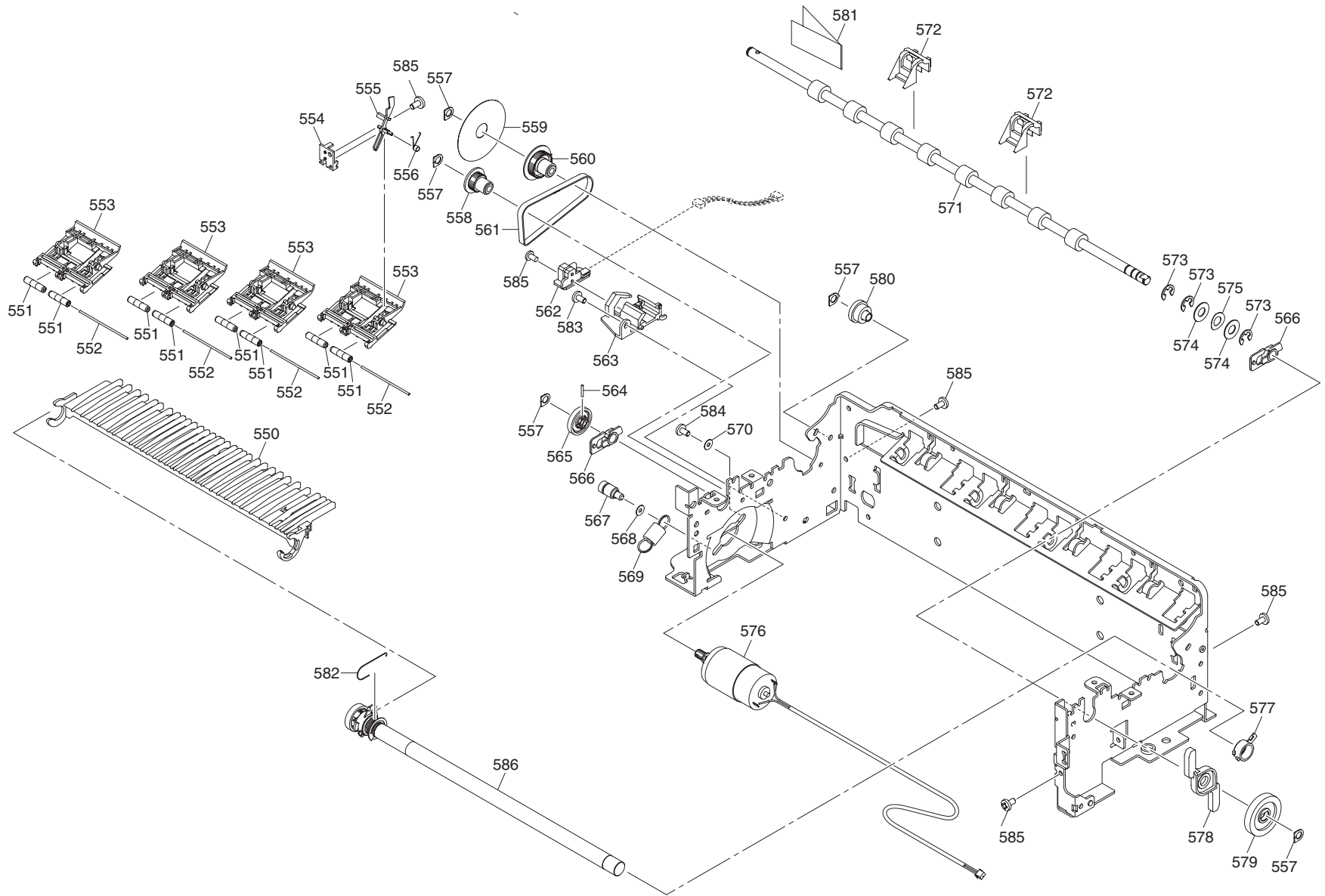

EPSON STYLUS C80 No.5 Rev.01 10336

Figure 7-10. Stylus Color C70/C80 Exploded Diagram 5

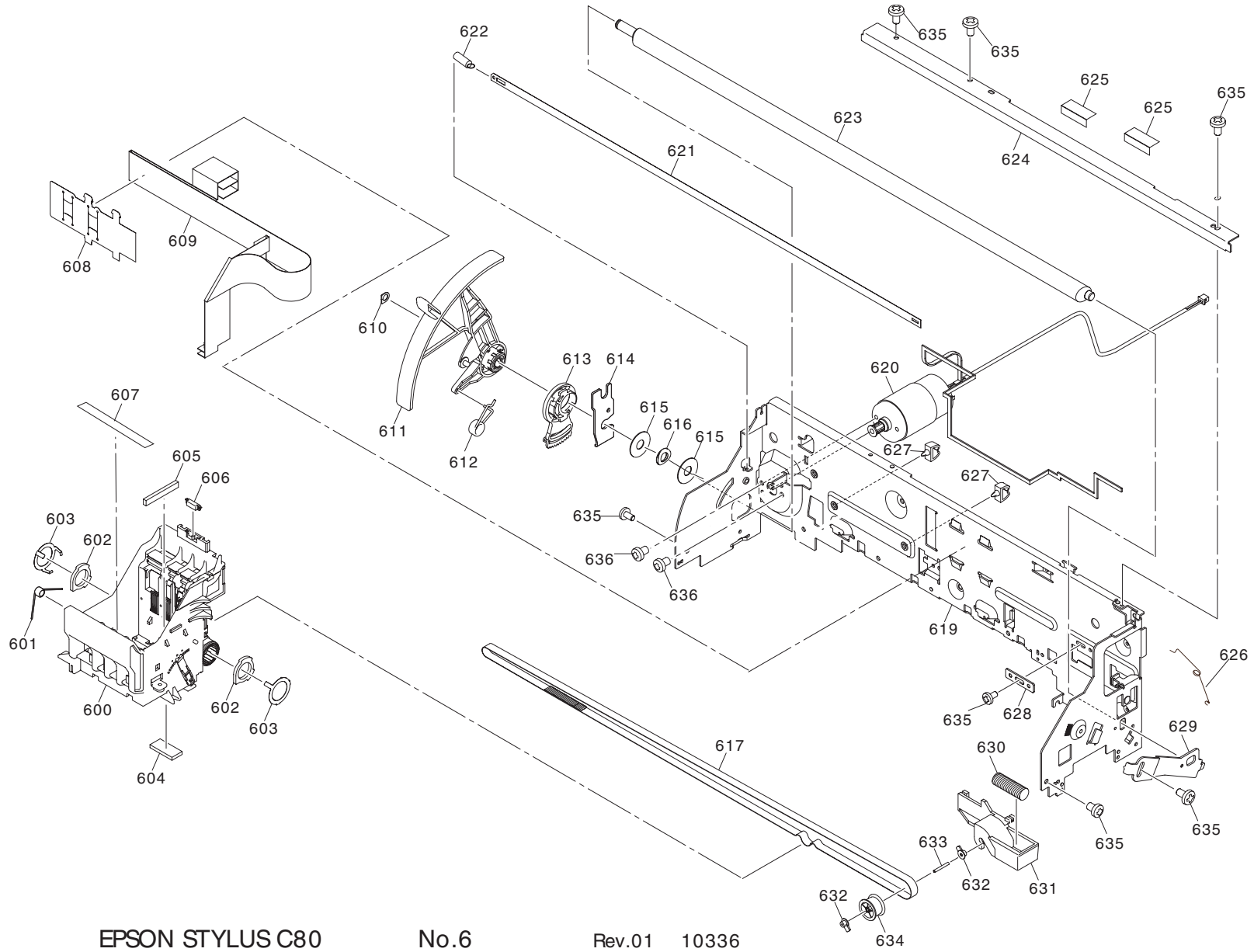

EPSON STYLUS C80

No.6

Rev.01 10336

Figure 7-11. Stylus Color C70/C80 Exploded Diagram 6

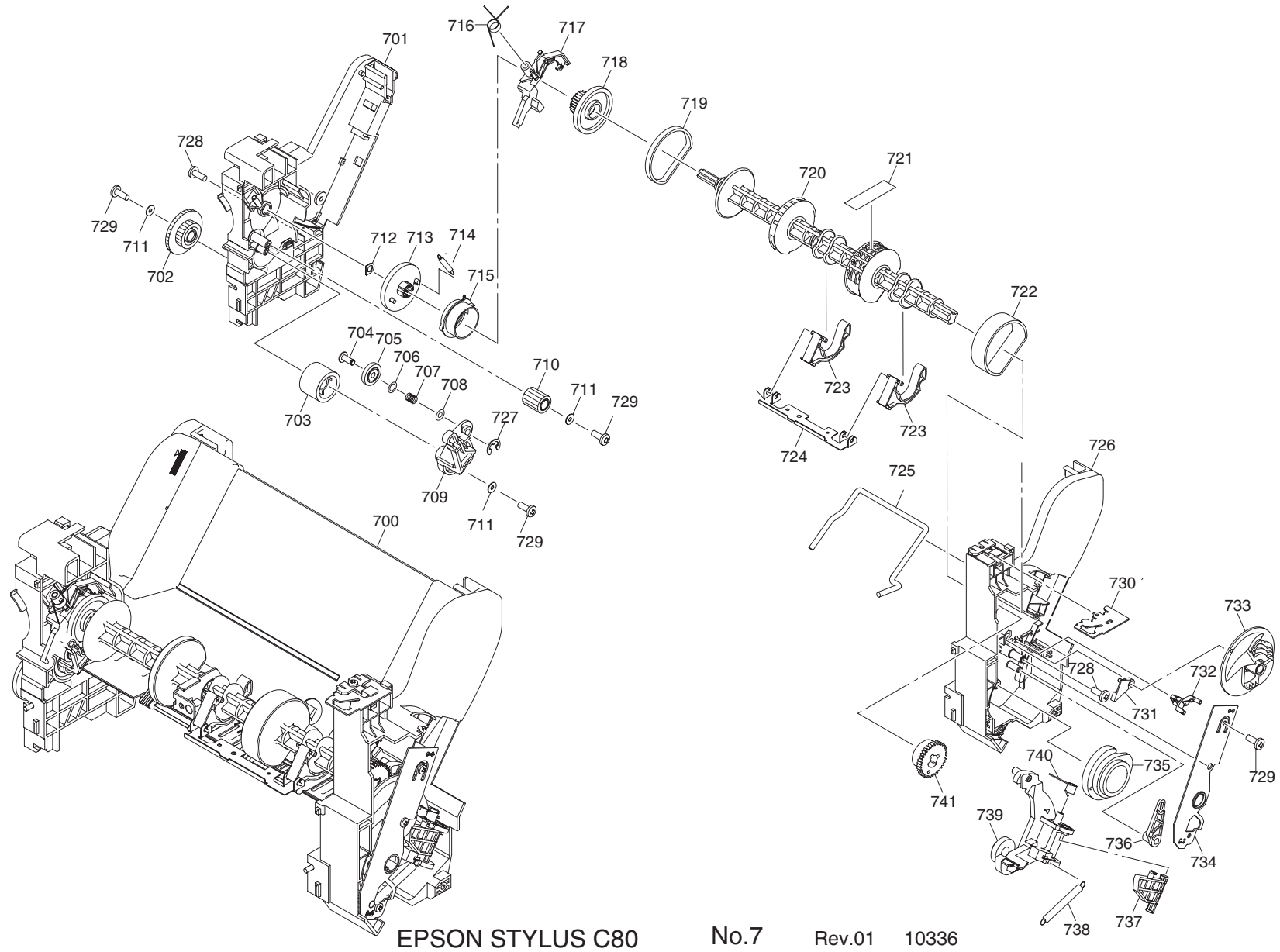
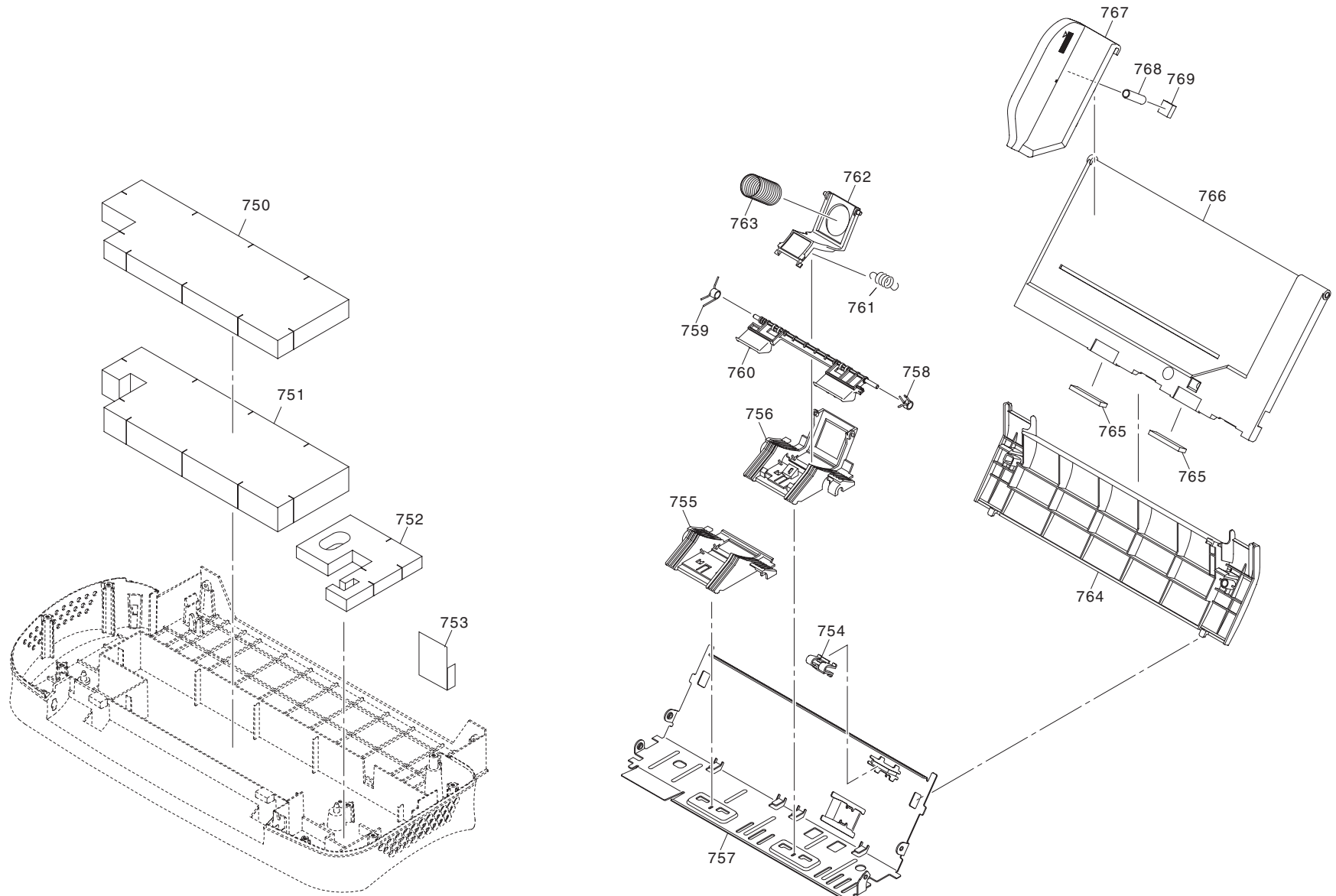

Figure 7-12. Stylus Color C70/C80 Exploded Diagram 7





EPSON STYLUS C80

No.8

Rev.01 10336

Figure 7-13. Stylus Color C70/C80 Exploded Diagram 8

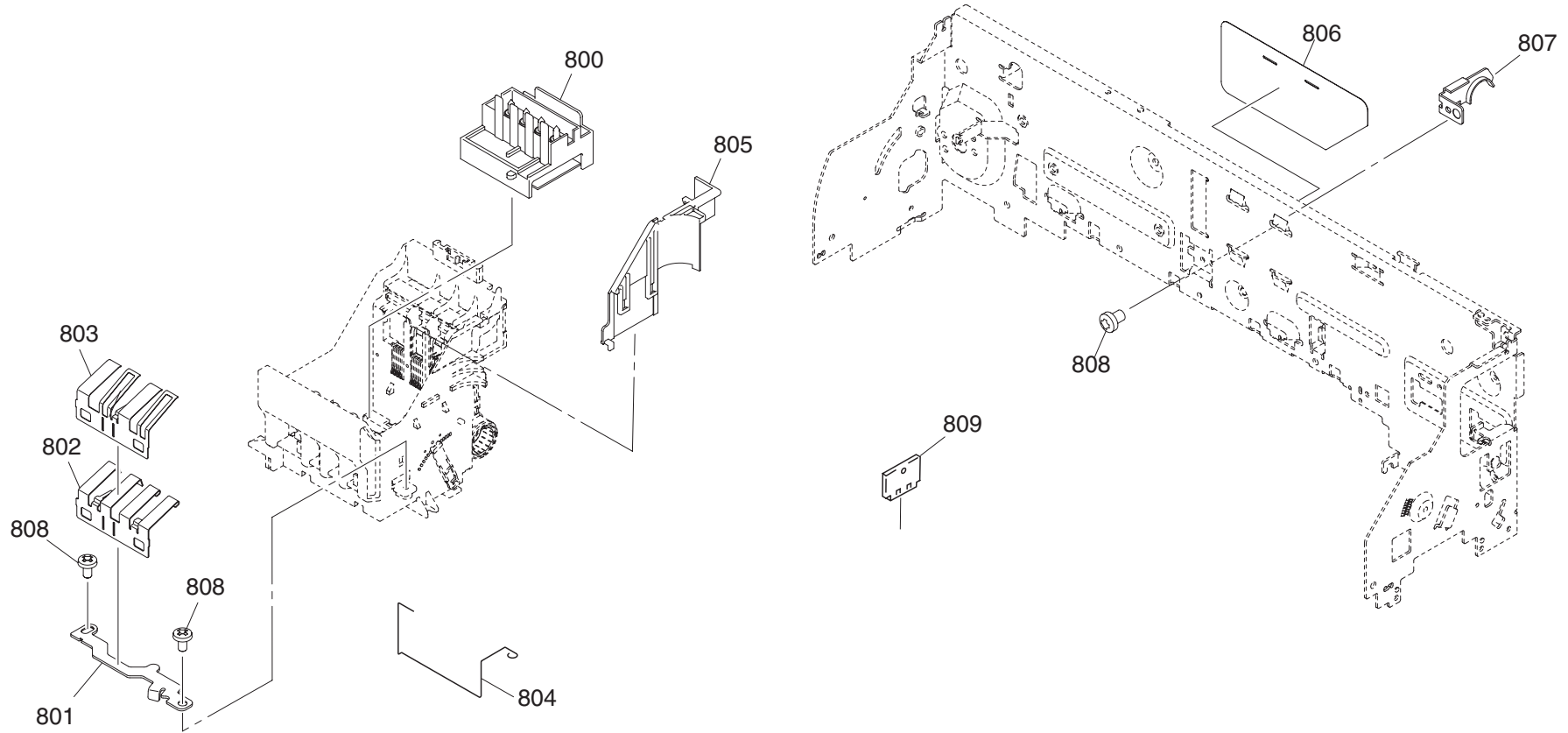

EPSON STYLUS C80

No.9

Rev.01 10336

Figure 7-14. Stylus Color C70/C80 Exploded Diagram 9

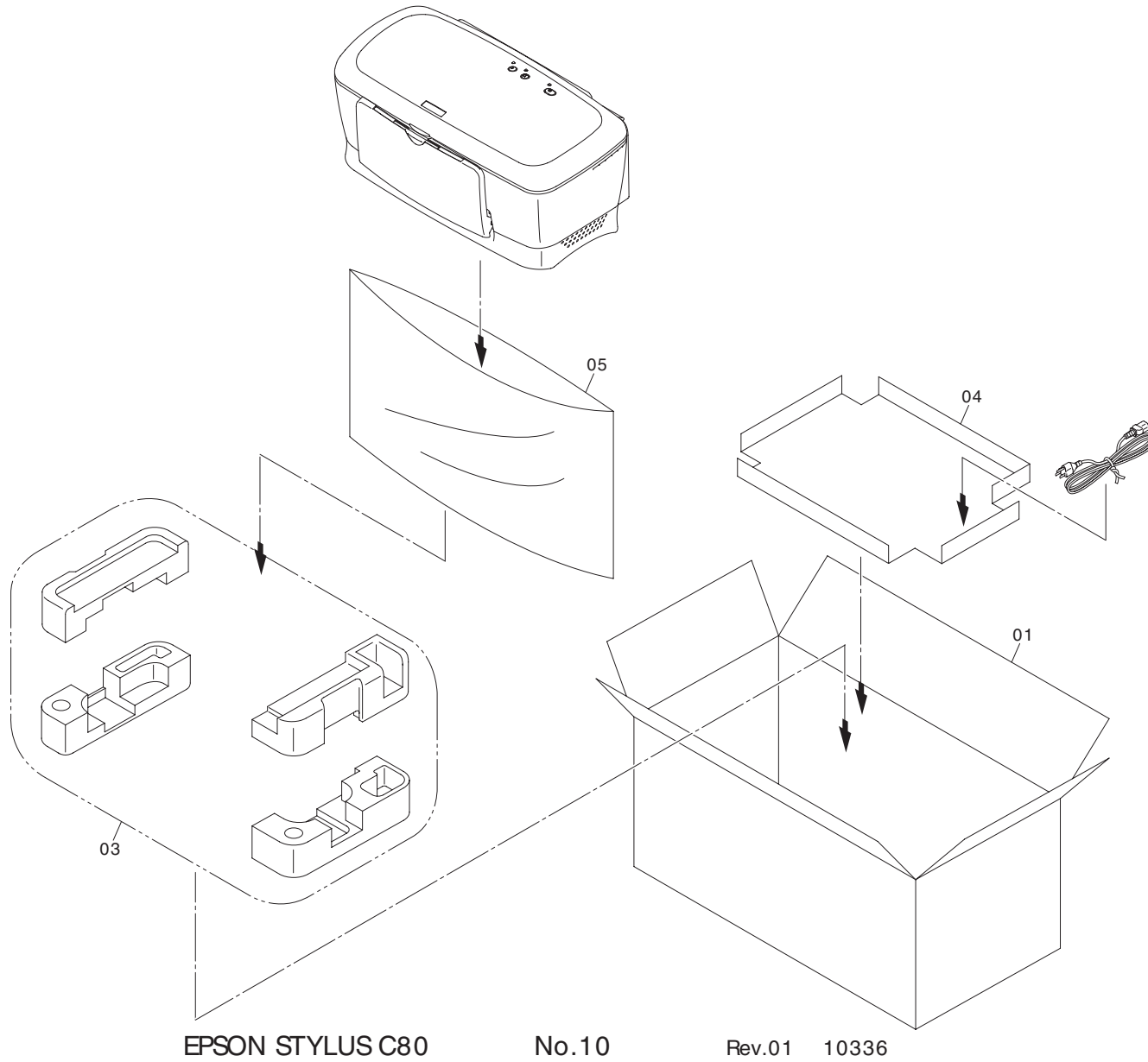

Figure 7-15. Stylus Color C70/C80 Exploded Diagram 10

## 7.4 Parts List

Table 7-10. Stylus Color C70/C80 Parts List

Code	Parts Name
100	HOUSING, LOWER
101	COMPRESSION SPRING, 2.94
102	LOCK, STACKER
103	FOOT
104	STACKER UNIT, ASP
105	LOGO PLATE 10 X 40; C
106	HOUSING, MIDDLE
107	BUTTON
108	BUTTON, PS
109	HOUSING, UPPER
110	LABEL, CAUTION
111	COVER, PRINTER; B
112	COVER, REAR
113	OPTICALPLATE
114	PAPER SUPPORT
115	C.B.P-TITE SCREW, 3 X 8, F/ZN
116	C.B.P-TITE, 3 X 10, F/ZN
117	C.B.P-TITE SCREW, 3 X 6, F/ZN
118	C.B.P.SCREW, 4 X 12, F/ZN
150	SHEET, SHIELDPLATE
151	SHIELDPLATE, M/B
152	SHIELDPLATE,M/B, SUPPORT

Table 7-10. Stylus Color C70/C80 Parts List

Code	Parts Name
153	SHIELDPATE, P/S,UPPER
154	COVER, CABLE
155	MOUNTING PLATE, AC INLET
156	SHIELDPATE, P/S, LOWER
157	C.B.(O) SCREW, 4 X 5, F/ZG
158	C.B.P-TITE SCREW, 3 X 8, F/ZN
159	C.B.S. SCREW (B300204211)
160	C.B.S. SCREW
161	PLANE WASHER 4.2 X 0.3 X 8 F/CR
162	C.B.S-TITE. SCREW, 3 X 8, F/ZN
200	BOARD ASSY., MAIN
201	HARNESS, ENCORDER
300	BOARD ASSY., POWER SUPPLY
400	POWER CABLE
500	PRINTER MECHANISM (ASP) M-A510-100
501	PAPER GUIDE, FRONT
502	GUIDE, INK, EJECT
503	FRAME ASSY., PF
504	PUMP ASSY
505	CAP, ASSY
506	TORSION SPRING, 161.16
507	STARWHEEL ASSY., 8
508	ROD SPRING, STAR WHEEL
509	HOLDER, STAR WHEEL, FRONT
510	HOLDER, STAR WHEEL, REAR

Table 7-10. Stylus Color C70/C80 Parts List

Code	Parts Name
511	STARHWEEL, 8; B
512	HOLDER, STARWHEEL, EJ
513	FRAME, EJECT
514	C.B.S. SCREW (B300204211)
515	GROUNDING WIRE, EJ
550	PAPER GUIDE, REAR
551	ROLLER, DRIVEN
552	SHAFT, ROLLER, DRIVEN
553	PAPER GUIDE, UPPER
554	HOLDER, DETECTOR, PE
555	LEVER, DETECTOR, P E
556	TORSION SPRING, 0.28
557	SPACER, 4.1 X 0.5, L/NA
558	COBINATION GEAR, 12, 16
559	SCALE ASSY., PF
561	TIMING BELT, PF
562	BOARD ASSY., ENCODER; B
563	MOUNT PLATE, BOARD ASSY., ENCODER
564	SCALLOP S.P SP-AW, 1.6 X 10, F/B
565	SPUR GEAR, 21.5
566	BUSHING, 5
567	SCREW, MOUNT, PF
568	PLANE WASHER 4.2 X 0.3 X 8 F/CR
569	EXTENSION SPRING, 17.2
570	PLAIN WASHER, 3.3 X 0.5 X 8, F/UC

Table 7-10. Stylus Color C70/C80 Parts List

Code	Parts Name
571	ROLLER ASSY., EJ
572	HOLDER, ROLLER ASSY., EJ
573	RETAINING RING (B150300711)
574	PLANE WASHER, 5.1 X 0.5 X 11, S/NA
575	U-TYPE SPRING, 5.2 X 0.13 X 10, S/NA
576	MOTOR ASSY., PF
577	BUSHING, 12, RIGHT
578	LEVER, CR, LOCK
579	SPUR GEAR, 19.2
580	COMBINATION GEAR, 9.5, 14.7
581	SHEET, PROTECTION, M/B
582	GROUNDING SPRING, PF
583	C.B.P-TITE, 2.5 X 5, F/ZN
584	CUP SCREW (B040302311)
585	C.B.S. SCREW (B300204211)
586	ROLLER PF UNIT, ASP
600	CARRIAGE UNIT, ASP
601	TORSION SPRING, 105
602	OIL PAD, RING
603	HOLDER, OIL PAD, RING
604	OIL PAD
605	POROUS PAD, CABLE, HEAD
606	SLIDER, CR
607	LABEL, CARRIAGE
608	SHEET, CABLE, HEAD

Table 7-10. Stylus Color C70/C80 Parts List

Code	Parts Name
609	CABLE, HEAD
610	SPACER, 4.1 X 0.5, L/NA
611	LEVER, PG
612	TORSION SPRING, 101.1
613	BUSH, PARALLELISM ADJUST, SUB, RIGHT
614	HOLDER, SHAFT, SUB, LEFT
615	PLAIN WASHER 6.1 X 0.5 X 12
616	LEAF SPRING (B101254590)
617	TIMING BELT, CR
619	FRAME, CR
620	MOTOR ASSY., CR
621	SCALE, CR
622	EXTENSION SPRING, 2.94
623	SHAFT, CR, GUIDE
624	GUIDE PLATE, CR
625	INSULATION, GUIDE PLATE, CR
626	TORSION SPRING, 190
627	MINI CLAMP
628	STOPPER, HOLDER, PULLEY, DRIVEN
629	LEVER, PARALLEL ADJUST
630	COMPRESSION SPRING, 28.27
631	HOLDER, PULLEY, DRIVEN
632	BUSHING, PULLEY, DRIVEN
633	SHAFT, PULLEY, DRIVEN
634	PULLEY, DRIVEN

Table 7-10. Stylus Color C70/C80 Parts List

Code	Parts Name
635	C.B.S. SCREW (B300204211)
636	C.P. SCREW, 3 X 4, F/ZN
700	ASF UNIT
701	FRAME, ASF, LEFT
702	COBINATION GEAR, 18.4, 32.8
703	SPUR GEAR, 22.4
704	SHAFT, PLANETARY MOUNT
705	SPUR GEAR, 15.2
706	PLAIN WASHER, 6.2 X 0.2 X 9, L/NA
707	COMPESSION SPRING, 3.944
708	PLAIN WASHER, 4.2 X 0.2 X 9, L/NA
709	LEVER, PLANETARY
710	SPUR GEAR, 12
711	PLANE WASHER 3.1 X 0.5 X 8.85 S/NA
712	U-TYPE, 11.2 X 0.13 X 16 S/NA
713	DRIVE, LD
714	EXTENSION SPRING, 0.143
715	CLUTCH
716	TORSION SPRING, 5.88
717	LEVER, CHANGE
718	COBINATION GEAR, RATCHET, 34.4
719	ROLLER, LD, SUPPORT
720	SHAFT ROLLER, LD
721	DOUBLE SIDED TAPE, 50 X 14.4
722	ROLLER, LD



Table 7-10. Stylus Color C70/C80 Parts List

Code	Parts Name
723	CAM, LEVER, LOCK
724	HOLDER, LEVER, ROCK
725	TORSIONBAR, HOPPER
726	FRAME, ASF, RIGHT
727	RETAINING RING (B150300611)
728	C.B.S-TITE. SCREW, 3 X 8, F/ZN
729	C.B.S. SCREW (B300204211)
730	MOUNTING PLATE, ASF
731	LEVER, SUB, PAPER BACK
732	LEVER, TRANSMISSION, PAPER BACK
733	CAM, SILENCE
734	COVER, CAM, SILENCE
735	CAM, LEVER, PAPER BACK
736	LEVER, PAPER BACK, SUPPORT
737	LEVER, SILENCE
738	EXTENTION SPRING, 0.5
739	SUPPORT, LEVER, SILENCE
740	TORSION SUPING, 1.41
741	SPUR GEAR, 28.8
750	POROUS PAD, INK EJECT; LOWER
751	POROUS PAD, INK EJECT; UPPER
752	POROUS PAD, INK, EJECT; RIGHT
753	SHEET, PROTECTION, HOUSING
754	HOLDER, TORSIONBAR, HOPPER
755	HOLLER, ASF, MIDDLE, LEFT

Table 7-10. Stylus Color C70/C80 Parts List

Code	Parts Name
756	HOLDER, ASF, MIDDLE
757	FRAME, ASF, LOWER
758	TORSION SPRING, 66.1
759	TORSION SPRING, 5.6
760	LEVER, PAPER BACK
761	COMPRESSION SPRING, 3.45
762	PAD ASSY., LD
763	COMPRESSION SPRING, 2.94
764	COVER, ASF
765	DAMPER, HOPPER; B
766	HOPPER ASSY
767	EDGE GUIDE
768	COMPRESSION SPRING, 5.61
769	FOOT, B
800	PRINT HEAD
801	FASTENER, HEAD
802	SPRING, CARTRIDEG
803	SPRING, CARTRIDGE, UPPER
804	HOLDER, HEAD CABLE
805	SPRING, FASTENER HEAD
806	INSULATION PLATE, CABLE, HEAD
807	COVER, ROLLER, LD
808	C.B.S. SCREW (B300204211)
01	INDIVIDUAL CARTON BOX FOR AMERICA

Table 7-10. Stylus Color C70/C80 Parts List

Code	Parts Name
03	PAD SET, PRINTER
04	PAD, ACCESSORY
05	PLASTIC PROTECTIVE BAG, 500 X 850 X 0.03T

## **7.5 Electrical Circuits**

---

The electric circuit diagrams below are shown at the following pages:

- C424 MAIN-B control circuit board
- C424 PSB power supply circuit board
- C424 PSE power supply circuit board

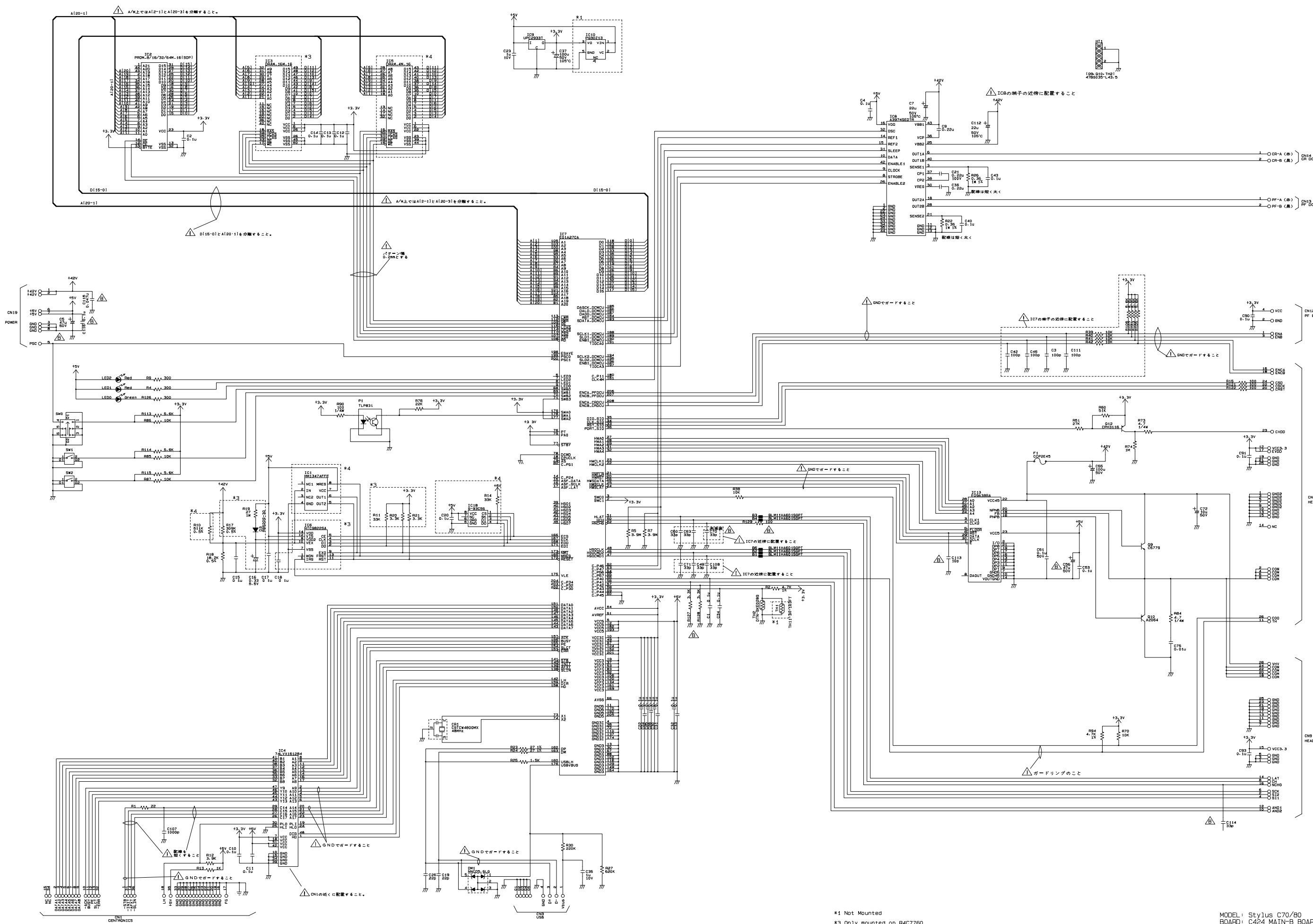

\*1 Not Mounted  
 \*3 Only mounted on R4C7750  
 \*4 Only mounted on R4C8240



1

2

3

4

5

6

